

Acuvim-L

Multifunction Power & Energy Meter Datasheet



DESCRIPTION

Designed for a wide range of standard metering projects, the Acuvim-L is a cost effective, multifunction power meter that combines value and high-performance with easy integration into panel or device monitoring applications. With multiple communication options including Modbus-RTU, PROFIBUS, Modbus-TCP/IP, and BACnet-IP through optional expansion modules and revenue grade accuracy, the Acuvim-L can be configured as either a panel-mount device, as a DIN rail mount transducer, or installed in a pre-configured, pre-wired AcuPanel for extreme protection in even the toughest application environments.

FEATURES

- + Revenue grade: ANSI C12.20 class 0.2 & IEC62053-22 class 0.2s
- + 4th CT input – measure neutral current
- + Dual Ethernet ports with both RSTP bridge daisy-chain mode and separately configurable network
- + Remote channel mapping and four channel multi-circuit metering
- + Dual source meter to monitor energy usage from separate energy sources
- + Data Logging available in 8MB onboard and 8GB with WEB2 module
- + Designed with industry leading cybersecurity
- + Available compatibility with multiple CT output options including 5A, RCT (Rogowski), or 333mV
- + Modbus-RTU & BACnet MS/TP ready. Optional modules add support for multiple industrial protocols & interfaces such as Modbus-TCP/IP, BACnet-IP, IEC61850, EtherNet/IP and WiFi

KEY FEATURES

Communication

- + Modbus RTU Protocol and BACnet MS/TP via RS485
- + Wi-Fi and Ethernet Communication Channels (Modbus TCP, BACnet IP, HTTP, SMTP, SNTP, HTTPs, Post, FTP)
- + PROFIBUS DP
- + Dual RJ45 ports with RSTP daisy-chain and two individually configurable Ethernet ports

Data Logging

- + Acuvim-L meters offer three, assignable historical logs and a real time clock to record metering parameters with accurate timestamping. Add the AXM-WEB2 module to expand the memory to 8GB with an adjustable log size.

Individual Channel Configuration

- + Acuvim-L meter can operate as a four channel multi-circuit meter and allow CT wiring configuration through remote channel mapping.

Time of Use

- + Users can assign up to four tariffs (sharp, peak, valley, & normal) to different time periods within a day. The Acuvim-L meter will calculate and accumulate energy to different tariffs according to the meter's internal clock and TOU settings.

Display

- + Clear, large character LCD with white backlight
- + Wide environmental temperature endurance
- + View load percentage, 4 quadrant powers, & load nature

Optional I/O Module

- + Expand Acuvim-L I/O functionality by connecting an optional I/O module. A maximum of three modules can be used per meter. Digital input, digital output, pulse output, relay output, analogue input, and analogue output I/O modules are available.

Alarms

- + Limits can be set for up to 16 indicated parameters with a specified time interval. Parameters that are over or under setting limit and persist longer than the specified time interval will be recorded and trigger the Alarm DO. Choose from 80 available parameters.

Flexible Current Transformer Options

- + The Acuvim-L is directly compatible with Rogowski coils plus a variety of other current transformer outputs including 5A, 1A, 333mV, and Rogowski coils. All CTs are available from Accuenergy.



APPLICATIONS

- + Power distribution automation
- + Medium and low voltage systems
- + Industrial automation
- + Energy management systems
- + Power quality analysis
- + Electric switch gear and control panels
- + Building automation
- + Marine applications

SPECIFICATIONS

Metering

PARAMETERS		ACCURACY	RESOLUTION	RANGE
Voltage		0.10%	0.1V	10V~1000kV
Current		0.10%	0.1mA	5mA~50000A
Power		0.20% (EL) or 0.50% (CL)	1W	-9999MW~9999MW
Reactive Power		0.20% (EL) or 0.50% (CL)	1var	-9999Mvar~9999Mvar
Apparent Power		0.20% (EL) or 0.50% (CL)	1VA	0~9999MVA
Power Demand		0.20% (EL) or 0.50% (CL)	1W	-9999MW~9999MW
Reactive Power Demand		0.20% (EL) or 0.50% (CL)	1var	-9999Mvar~9999Mvar
Apparent Power Demand		0.20% (EL) or 0.50% (CL)	1VA	0~9999MVA
Power Factor		0.10%	0.001	-1.000~1.000
Frequency		0.00%	0.001Hz	45.00~65.00Hz
Energy	Primary	0.20% (EL) or 0.50% (CL)	0.1kWh	0-99999999.9kWh
	Secondary	0.20% (EL) or 0.50% (CL)	0.001kWh	0-999999.999kWh
Reactive Energy	Primary	0.20% (EL) or 0.50% (CL)	0.1kvarh	0-99999999.9kvarh
	Secondary	0.20% (EL) or 0.50% (CL)	0.001kvarh	0-999999.999kvarh
Apparent Energy	Primary	0.20% (EL) or 0.50% (CL)	0.1kVAh	0-99999999.9kVAh
	Secondary	0.20% (EL) or 0.50% (CL)	0.001kVAh	0-999999.999kVAh
Harmonics		1.00%	0.1%	
Phase Angle		2.00%	0.1°	0.0°~359.9°
Unbalance Factor		2.00%	0.1%	0.0%~100.0%
Running Time		0.01h	0.01h	0~9999999.99h

Input

CURRENT INPUTS (EACH CHANNEL)

Nominal Current Options	① 5A, ② 1A, ③ 1A (333mV) ④ 1A (100mV Rope CT)
Metering Range	① 0-10A, ② 0-2A, ③ 0-1.2A, ④ 0-1.2A
Pickup Current	① 5mA, ② 1mA, ③ 5mA, ④ 5mA
Withstand	20Arms Continuous, 0.1% of Nominal 100Arms for 1 second, Non-Recurring
Burden	0.05VA (Typical) @ 5A RMS
Accuracy	0.1% at Reading

VOLTAGE INPUTS (EACH CHANNEL)

Nominal Full Scale	400Vac L-N, 690Vac L-L (+20%)
Withstand	1500Vac Continuous 2500Vac, 50/60Hz for 1 Minute
Input Impedance	2MΩ per Phase
Metering Frequency	45Hz~65Hz, 300Hz~500Hz
Pickup Voltage	10Vac
Accuracy	0.1% at Reading

ENERGY ACCURACY

Active	Class 0.2s for Acuvim-EL and Class 0.5s for Acuvim-CL (IEC 62053-22) Class 0.2 for Acuvim-EL and Class 0.5s for Acuvim-CL (ANSI C12.20)
Reactive	Class 0.5 (IEC62053-24)

HARMONIC RESOLUTION

Metered Value	2 nd to 63 rd Harmonic (50Hz or 60Hz type) for Acuvim-EL 2 nd to 31 st Harmonic (50Hz or 60Hz type) for Acuvim-CL
---------------	--

Communications

Modbus-RTU or BACnet MS/TP	Modbus-RTU 2-Wire Shielded Twisted Pair Cable Connection 1200~115200 bps
SECOND RS-485 PORT (OPTIONAL MODULE)	Same as the primary RS485 port Baud Rate: 4800~38400 bps
ETHERNET (OPTIONAL MODULE)	Ethernet 10M/100M BaseT MODBUS-TCP/IP DNP 3.0 Over IP IEC 61850 2nd Edition SNMP V3 BACnet-IP HTTP/HTTPs Webserver HTTP/HTTPs, FTP data post SMTP MQTT NTP
PROFIBUS (OPTIONAL MODULE)	PROFIBUS-DP/V0 Protocol Work as PROFIBUS Slave, Baud Rate Adap- tive, up to 12M Model 1: Input Bytes: 32, Output Bytes: 32 Model 2: Input Bytes: 64, Output Bytes: 2 PROFIBUS Standard According to EN 50170 Vol. 2

SPECIFICATIONS

I/O Options

DIGITAL INPUT

Input Type	Dry
Input Resistance	100kΩ
Input Voltage Range	20~160 Vac/dc
Input Current (Max)	2mA
Start Voltage	15V
Stop Voltage	5V
Pulse Frequency (Max)	100Hz, 50% Duty Ratio (5ms ON and 5ms OFF)
SOE Resolution	2ms

DIGITAL OUTPUT (DO) (PHOTO-MOS)

Voltage Range	0~250Vac/dc
Load Current	100mA (Max)
Output Frequency	25Hz, 50% Duty Ratio (20ms ON, 20ms OFF)
Isolation Voltage	2500Vac

RELAY OUTPUT (RO) (NO, Form A)

Switching Voltage (Max)	250Vac, 30Vdc
Load Current	5A(R), 2A(L)
Set Time	10ms (Max)
Contact Resistance	30mΩ (Max)
Isolation Voltage	2500Vac
Mechanical Life	1.5x10 ⁷

ANALOGUE OUTPUT (AO)

Output Range	0~5V, 0~20mA 1~5V, 4~20mA Optional
Accuracy	0.50%
Temperature Drift	50ppm/°C Typical
Isolation Voltage	500Vdc
Open Circuit Voltage	15V

ANALOGUE INPUT (AI)

Input Range	0~5V, 0~20mA 1~5V, 4~20mA Optional
Accuracy	0.20%
Temperature Drift	50ppm/°C Typical
Isolation Voltage	500Vdc

POWER SUPPLY FOR DI (24 VDC)

Output Voltage	24Vdc
Output Current	42mA
Load (Max)	21DIs

Control Power

Universal	AC or DC
-----------	----------

AC/DC CONTROL POWER

Operating Range	100~415Vac, 50/60Hz; 100~300Vdc
Burden	5W
Frequency	50/60Hz
Withstand	3250Vac, 50/60Hz for 1 minute
	Installation Category III (Distribution)

LOW VOLTAGE DC CONTROL POWER (OPTIONAL)

Operating Range	20~60Vdc
Burden	5W

Operating Environment

Operating Temperature	-25°C to 70°C -13°F to 158°F
Storage Temperature	-40°C to 85°C -40°F to 176°F
Relative Humidity	5% to 95% Non-Condensing

Standard Compliance & Certifications





Measurement Standard	IEC 62053-22; ANSI C12.20; IEC61557-12
Environmental Standard	IEC 60068-2, CE, RoHS
Safety Standard	IEC 61010-1, UL 61010-1
EMC Standard	IEC 61000-4/-2-3-4-5-6-8-11, CISPR 22, IEC 61000-3-2, IEC 61000-6-2/4
Outlines Standard	DIN 43700, ANSI C39.1
Protocol Conformance	IEC 61850 2nd Edition

FUNCTION LIST



	REAL TIME METERING	Parameters	Acuvim-CL	Acuvim-EL
Metering	Phase Voltage	V1, V2, V3, Vlnavg	●	●
	Line Voltage	V12, V23, V31, Vllavg	●	●
	Current	I1, I2, I3, I4, In, Iavg	●	●
	Power	P1, P2, P3, Psum	●	●
	Reactive Power	Q1, Q2, Q3, Qsum	●	●
	Apparent Power	S1, S2, S3, Ssum	●	●
	Power Factor	PF1, PF2, PF3, PF	●	●
	Frequency	F	●	●
	Load Features	Load Features	●	●
	Four Quadrant Powers	Four Quadrant Powers	●	●
ENERGY & DEMAND				
	Energy	Ep_imp, Ep_exp, Ep_total, Ep_net, Epa_imp, Epa_exp, Epb_imp, Epb_exp, Epc_imp, Epc_exp	●	●
	Reactive Energy	Eq_imp, Eq_exp, Eq_total, Eq_net, Eqa_imp, Eqa_exp, Eqb_imp, Eqb_exp, Eqc_imp, Eqc_exp	●	●
	Apparent Energy	Es, Esa, Esb, Esc	●	●
	Demand	Dmd_P, Dmd_Q, Dmd_S, Dmd_I1, Dmd_I2, Dmd_I3	●	●
TOU	TIME OF USE			
	Energy/max demand	TOU, 4 Tariffs, 12 Seasons, 14 Schedules	●	●
	DAYLIGHT SAVINGTIME			
	Two Adjustable Formats	Month/Day/Hour/Minute, Month/Week/First few Weeks/Hour/Minute	●	●
Monitoring	POWER QUALITY			
	Voltage Unbalance Factor	U_unbl	●	●
	Current Unbalance Factor	I_unbl	●	●
	Voltage THD	THD_V1, THD_V2, THD_V3, THD_Vavg	●	●
	Current THD	THD_I1, THD_I2, THD_I, THD_Iavg	●	●
	Individual Harmonics	Harmonics	2nd to 31st	2nd to 63rd
	Voltage Crest Factor	TIF THFF	●	●
	Current K factor	K Factor	●	●
STATISTICS				
	MAX with Time Stamp	Each phase of V & I; Total of P, Q, S, PF & F; Demand of I1, I2, I3, P, Q&S;	●	●
	MIN with Time Stamp	Each phase THD of V & I; Unbalance factor of V & I		
Others	ALARM			
	Over/Under Limit Alarm	V, I, P, Q, S, PF, V_THD & I_THD Each Phase and Total or Average; Unbalance Factor of V & I; Load Type; Analogue Input of Each Channel; Demand of I1, I2, I3, P, Q&S; Reverse phase sequence; DI1~DI28	●	●
	DATA LOGGING			
Data Logging 1	F, V1/2/3/lnavg, V12/23/13/lavg, I1/2/3/n/avg, P1/2/3/sum, Q1/2/3/sum, S1/2/3/sum, PF1/2/3, PF, U_unbl, I_unbl, Load Type, Ep_imp, Ep_exp, Ep_total, Ep_net, Eq_imp, Eq_exp, Eq_total, Eq_net, Es, Epa_imp, Epa_exp, Epb_imp, Epb_exp, Epc_imp, Epc_exp, Eqa_imp, Eqa_exp, Eqb_imp, Eqb_exp, Eqc_imp, Eqc_exp, Esa, Esb, Esc, THD_V1/2/3/avg, THD_I1/2/3/avg, Harmonics 2nd to 63rd, Crest Factor, THFF, K Factor, Sequence and Phase Angles, DI Counter, AI, AO, Dmd P/Q/S, Dmd I1/2/3	●	●	
Data Logging 2				
Data Logging 3				
ONBOARD MEMORY SIZE				
Memory	Standard Meter		8MB	8MB
	AXM-WEB2		8GB	8GB
COMMUNICATION				
RS485 Port, Half Duplex, Optical Isolated	Modbus-RTU and BACnet-MS/TP		●	●
TIME				
Real Time Clock	Year, Month, Date, Hour, Minute, Second		●	●

COMMUNICATION MODULE COMPARISON

● Function; Blank NA

	Standard	AXM WEB2 FOLC	AXM WEB2	AXM PROFI	AXM RS485
					
Modbus-RTU	●				●
BACnet-MS/TP	●				
DNP 3.0 Over IP		●	●		
IEC 61850		●	●		
Modbus-TCP/IP		●	●		
HTTP/HTTPs Webserver		●	●		
SMTP Email		●	●		
SNMP V3		●	●		
EtherNet/IP		●	●		
MQTT		●	●		
RSTP		●	●		
IPv6		●	●		
HTTP/HTTPs Push		●	●		
FTP Post		●	●		
sFTP Server		●	●		
Datalogging	8MB	8GB	8GB		
BACnet-IP		●	●		
PROFIBUS				●	
WiFi		●	●		
RJ45 Ports		1	2		
Fiber Optics LC		●			

DIGITAL/ANALOGUE I/O

	AXM-IO1	AXM-IO2	AXM-IO3
			
Digital Input (<i>Dry</i>)	6	4	4
Digital Output	-	2	-
Relay Output	2	-	2
Analogue Inputs	-	-	2
Analogue Outputs	-	2	-
Power Supply	24Vdc	-	-

DIMENSIONS

Acuvim-L Dimensions

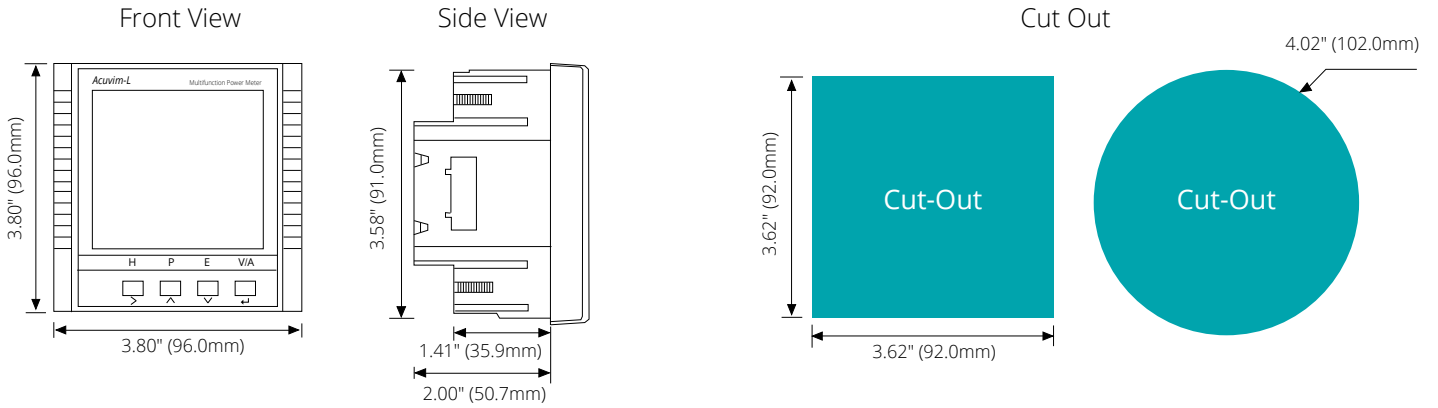

DIN Mount Meter Dimensions

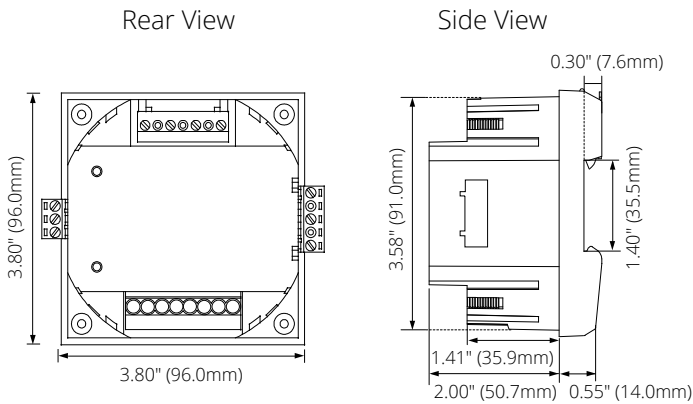

External Display Module Dimensions

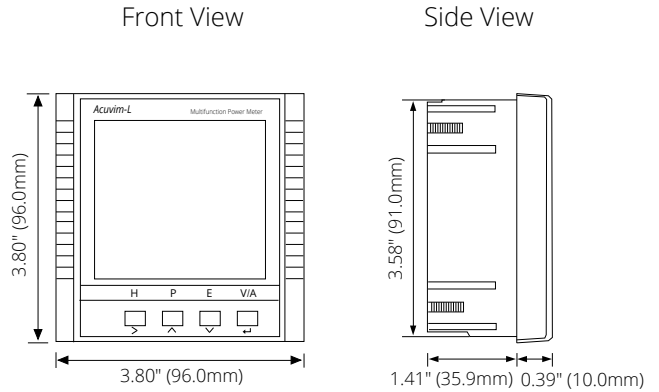

- Note:**
1. Display module is connected with a six foot 10 pin RJ45 cable, if you need a longer cable please specify that in the ordering statement.
 2. Display module opening size and Acuvim-L body openings are exactly the same size.

I/O Module Dimensions

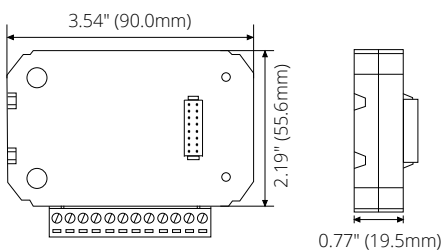

Communication Module Dimensions

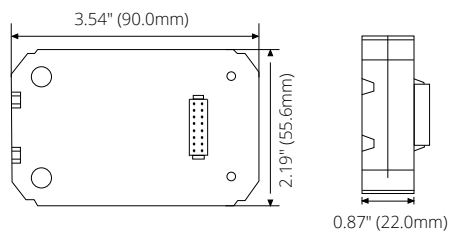

WIRING DIAGRAMS

Typical Wiring With 5A/1A CTs

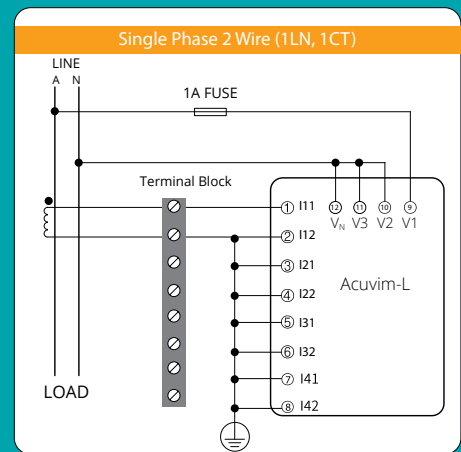
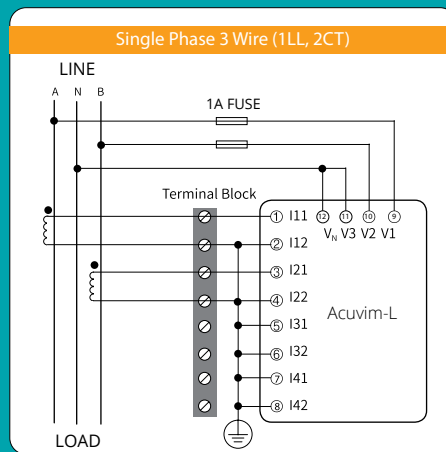
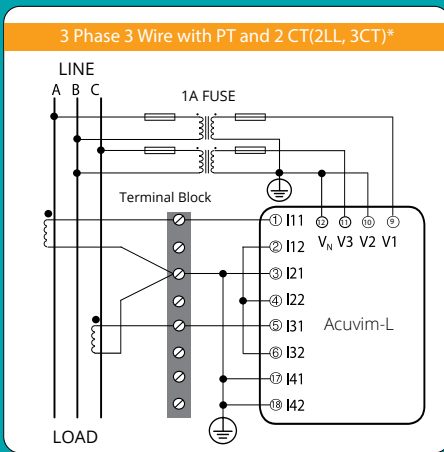
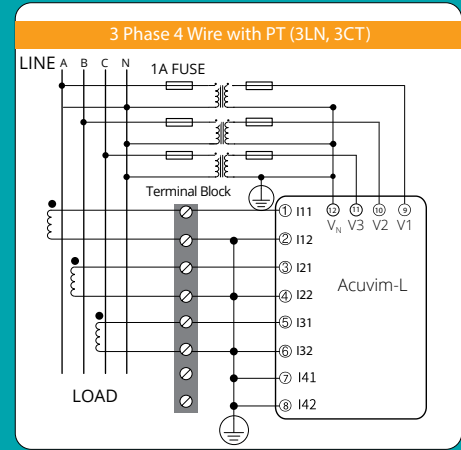
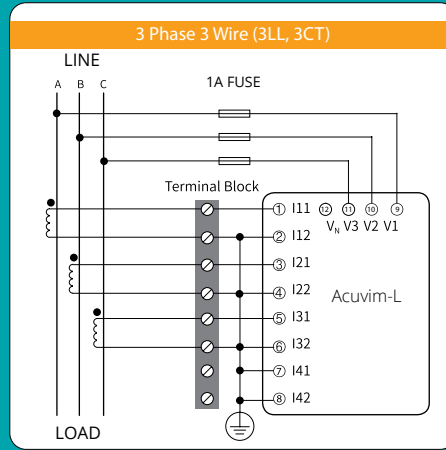
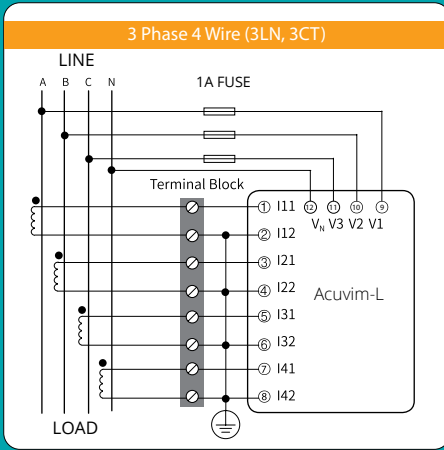

I/O Module Wiring

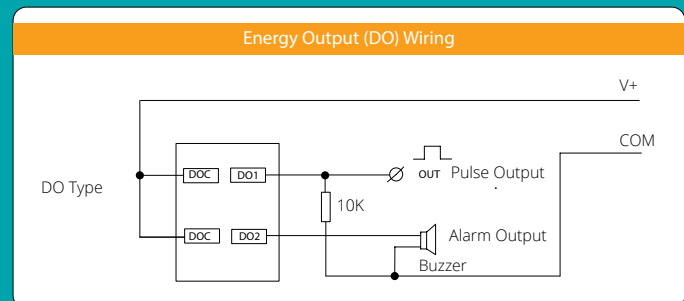
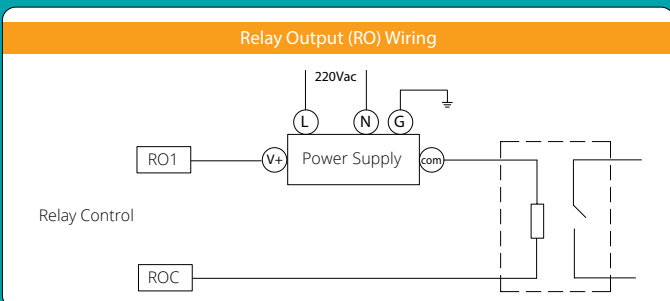
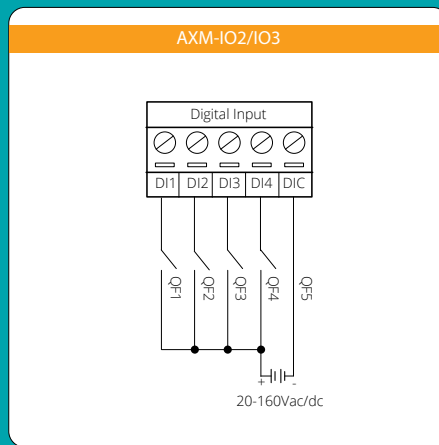
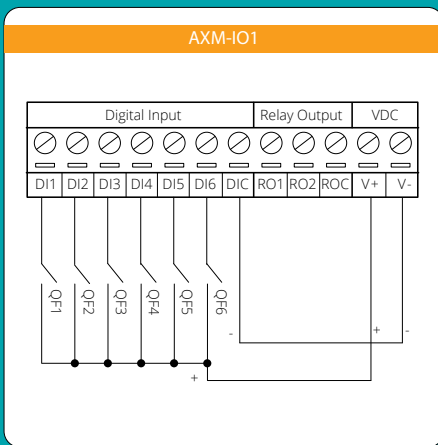

*Note: 2CT configuration is optional only in 3 Phase 3 Wire system.

WIRING DIAGRAMS

Typical Wiring RCT/mV/ Current Input

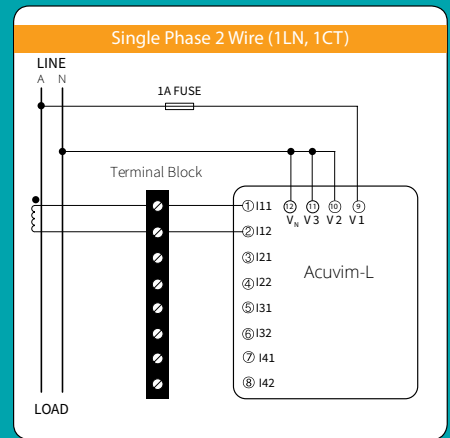
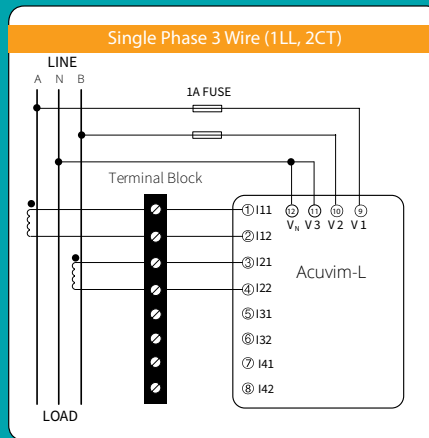
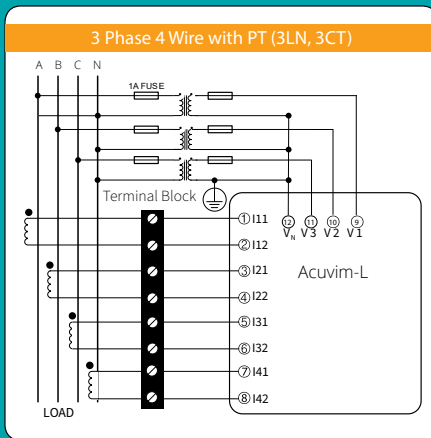
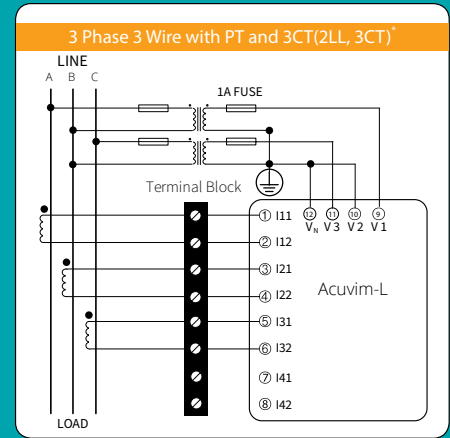
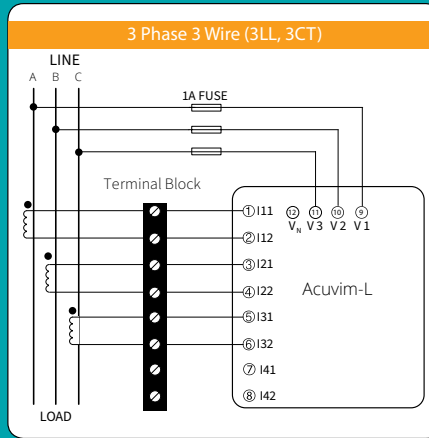
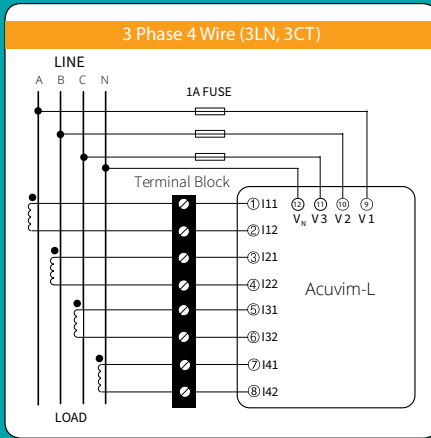

*Note: 2CT configuration is optional only in 3 Phase 3 Wire system.

ACCESSORIES

DIN Rail Adapter

The AXM-DIN Rail Adapter is the easy way to mount the Acuvim-L Series energy meter on either horizontal or vertical DIN rail. The adapter quickly secures to the meter and is compatible with all AXM communication modules as well as I/O options.



Protective Display Cover

The Protective Display Cover is designed for Acuvim-L Series energy meters and other 96mm by 96mm display panel meters. Crucial in harsh environments, it increases the IP environmental rating of a meter's display to IP66 or NEMA 4X.



USB RS485 Converter

This plug-and-play USB to Serial RS485 Converter is designed to provide a convenient, reliable USB connection to the Acuvim-L Series power meters and other serial devices.



ORDERING INFORMATION

Function Model	Mounting Option	Current Input	Power Supply
Acuvim-CL Energy class 0.5 Harmonics up to 31st	D: Panel Mounting with Display	5A: Allow user to select 1A/5	P1V4: 100~415Vac, 50/60Hz, 100~300Vdc
Acuvim-EL Energy class 0.2 Harmonics up to 63rd	M: DIN-Rail Mounting without Display	mV: Allow user to select 333mV/ RCT	P2V4: 20~60Vdc
Ordering Example:	Acuvim-CL-D-5A-P1V4		

Communication Module (Optional)	Protocols
AXM	WEB2-FOLC: IEC 61850, Modbus-TCP, HTTP/HTTPS Webserver, SMTP Email, SNMP, HTTP/HTTPS Push, FTP Post, sFTP Server, BACnet-IP, Datalogging, WiFi, Fiber Optics LC WEB2: IEC 61850, Modbus-TCP, HTTP/HTTPS Webserver, SMTP Email, SNMP, HTTP/HTTPS Push, FTP Post, sFTP Server, BACnet-IP, Datalogging, WiFi PROFI: PROFIBUS RS485: Modbus-RTU
Ordering Example:	AXM-RS485 AXM-WEB2

I/O Module (Optional)	Logic Module	Input/Output Type
AXM-IO1	1	
	2	
Ordering Example:	AXM-IO1-1	
AXM-IO2	1	A: 4~20mA
AXM-IO3	2	B: 0~20mA
		C: 1~5V
		D: 0~5V
Ordering Example:	AXM-IO3-1B	

Accessories (Optional)
REM-DS1V4: Remote Display <i>(Only for Acuvim-L DIN-Rail Mount "M" option)</i>
AXM-DIN: DIN Rail Adapter
IP66/NEMA4X: Environmental Protection Cover
USB-RS485: USB-to-RS485 Converter
Ordering Example:
AXM-DIN

- Note:
1. Refer to the Communication table and Digital/Analogue I/O table on page 6.
 2. A maximum of 3 modules may be attached to the meter. If a communication module is used (e.g. AXM-WEB2), it must be installed on the back FIRST before the other I/O modules are attached.
 3. No more than 2 of the same I/O modules may be attached to the meter (e.g. two AXM-IO2). The same two I/O modules must have a different logic number.



www.mod-tronic.com | sales@mod-tronic.com | 1-800-794-5883

Revision Date: April 2023 Version: 2.0.0
Specs Subject To Change Without Notice.



ISO9001 Certified