

AT/ATR-FL SERIES

AC Current Transducers

AT/ATR-FL Series AC Current Transducers combine a current transformer and a signal conditioner into a single package for applications from 100 A to 2000 A. The AT version is Average Responding for use on linear (sinusoidal) loads. The ATR version is True RMS for use on distorted waveforms found in VFD or SCR outputs. The AT/ATR-FL Series AC Current Transducers are available in a solid-core case.

AC Current Transducer Applications

Large Pumps

- Detect dry run electronically.

Power Generation

- Measure the output of generators.

Electric Heating Elements

- Monitors heater loads.
- Faster response than temperature sensors.

Motor Load Monitoring

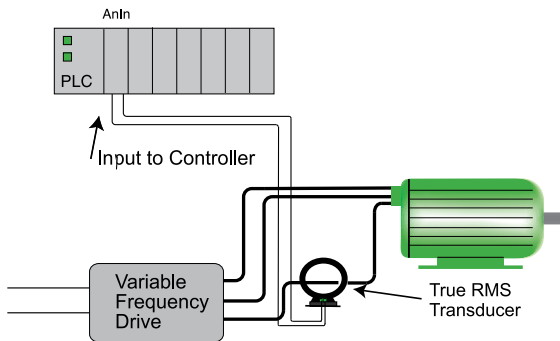

- For additional Application Examples, go to www.nktechnologies.com/applications

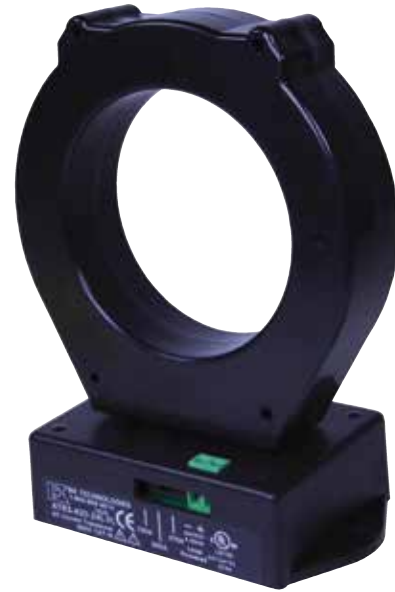

AC Current Transducer Features

Large Aperture

- Accommodates large conductors or wire bundles.

Select the Right Output

- True RMS technology is accurate on distorted waveforms like those associated with VFD or SCR outputs.
- Average Responding for use with linear, sinusoidal waveforms.

Jumper-selectable Ranges

- Reduces inventory.
- Eliminates zero and span pots.

Isolation

- Output is magnetically isolated from the input for safety.
- Eliminates insertion loss (voltage drop).

UL/cUL and CE Approved

- Accepted worldwide.

Selecting the right transducer:

The current waveforms of a typical linear load is a pure sine wave. AT transducers measure the peaks of these sine waves, then calculate the average amperage. This works well on constant speed linear loads in “clean” power environments. Select AT transducers for strictly linear loads on “clean” power.

VFD and SCR output waveforms are rough approximations of a sine wave. There are numerous spikes and dips in a mathematical algorithm called “True RMS,” which integrates the actual waveforms over time. The output is the amperage component of the true power (heating value) of the AC current waveforms. True RMS is the only way to accurately measure distorted AC waveforms. **Select ATR transducers for nonlinear loads on “noisy power.”**

OEMs Test & Evaluation Units for OEMs
Free program expedites evaluation process. See page 3 for details.

AC Current Transducer Dimensions

FL Case

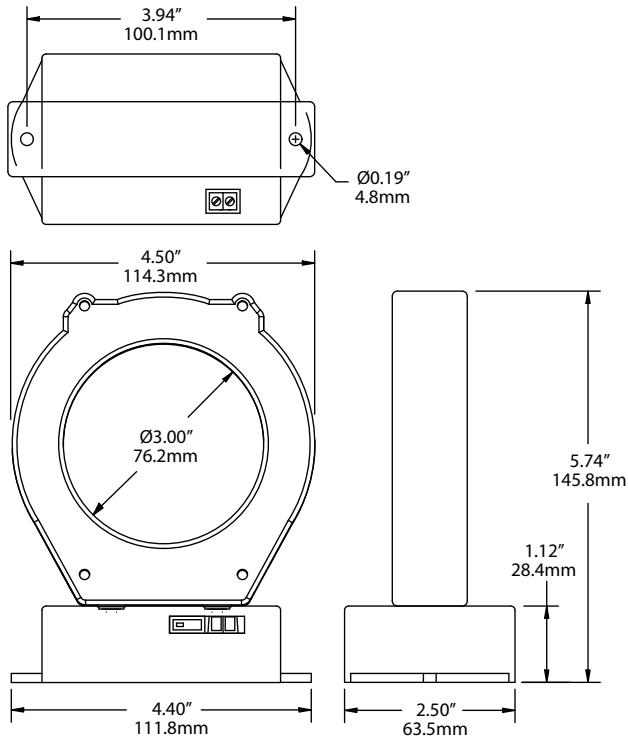

AC Current Transducer Connections

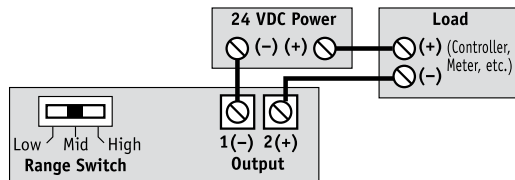

Notes:
 Deadfront captive screw terminals.
 12–22 AWG solid or stranded.
 Observe polarity.

AC Current Transducer Specifications



Power Supply	24 VDC
Output Signal	4–20 mA loop-powered, average or True RMS
Output Limit	23 mA
Output Impedance	<750 Ω @ 24 VDC
Accuracy	1.0% FS, True RMS
Measurement	True RMS or Average Responding (see ordering information)
Response Time	600 ms (to 90% step change)
Frequency Range	• ATR: 10–400 Hz • AT: 50–60 Hz, sinusoidal
Isolation Voltage	UL listed to 600 VAC, tested to 5 KV
Input Range	• AT/ATR2: 100, 133, 200 A • AT/ATR3: 375, 500, 750 A • AT/ATR4: 1000, 1333, 2000 A
Case	UL94 V-0 Flammability Rated
Environmental	-4 to 122°F (-20 to 50°C) 0–95% RH, non-condensing
Listings	UL/cUL, CE

AC Current Transducers

AC Current Transducer Ordering Information

Sample Model Number: ATR3-420-24L-FL
 True RMS AC current transducer, 24 VDC, powered with a 4–20 mA output, 375/500/750 A ranges in a solid-core case.



(1) Measurement	R	True RMS
		Average Responding (blank)
(2) Full Scale Range	2	100, 133, 200 A
	3	375, 500, 750 A
	4	1000, 1333, 2000 A
(3) Output Signal	420	4–20 mA
(4) Power Supply	24L	24 VDC loop-powered
(5) Case Style	FL	Solid-core

