

# AT/ATR-MS SERIES

## AC Current Transducers

AT/ATR-MS Series Current Transducers combine a current sensing element and signal conditioner into a single package. The large, easy-to-install split-core design allows for installation over existing conductors without the need to disconnect the load, even in applications where there are multiple conductors per phase. Whether installing over existing conductors or in a new control system, installation is very simple and quick. Just remove the top portion of the sensing ring, place the conductors inside, and snap the top back in place. The transducer uses two wires to connect to the power supply or the load (a programmable logic controller, a panel meter, or a data acquisition system).



### AC Current Transducer Applications

#### Monitor Large Machines

- Measure the current use to detect over or undercurrent conditions before they cause break downs.

#### Water Delivery and Treatment

- Detect open discharge lines.
- Locate clogged filters or blocked intake to pumps.

#### Grinding and Shredding

- An analog output will allow the control system designer to allow brief periods of drive overload when the processed product varies in density. If the blades hit something foreign (e.g. steel when the machine is designed to reduce paper), then the control will alarm or shut down the process.

### AC Current Transducer Features

#### Industry Standard Output

- 4–20 mA signal proportional to the AC current.
- Compatible with most automation systems.

#### Loop-powered

- Use the “live zero” output to verify proper connections, where the sensor output is 4 mA with no current through the sensing ring.

#### Factory Calibrated

- Eliminates zero and span potentiometer adjustment.

#### Split-core Case

- Sensing window provides ample space for bus bar, single or multiple conductors.

#### DIN Rail Mounted Case\*

- Simply snaps onto DIN rail for secure mounting.

#### UL/cUL and CE Approved

- Accepted worldwide.

\*For information on the DIN rail accessories kit, see page 140.

Shredder Monitoring

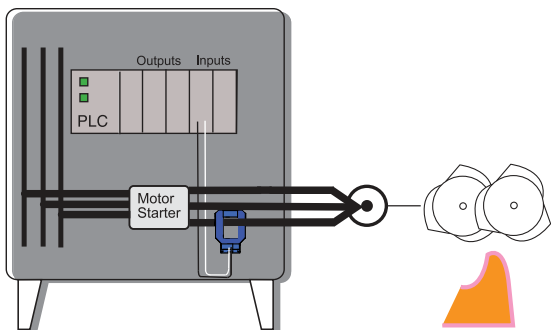

- For additional Application Examples, go to [www.nktechnologies.com/applications](http://www.nktechnologies.com/applications)

**OEMs** Test & Evaluation Units for OEMs  
Free program expedites evaluation process. See page 3 for details.

AC Current Transducer Dimensions

MS Case

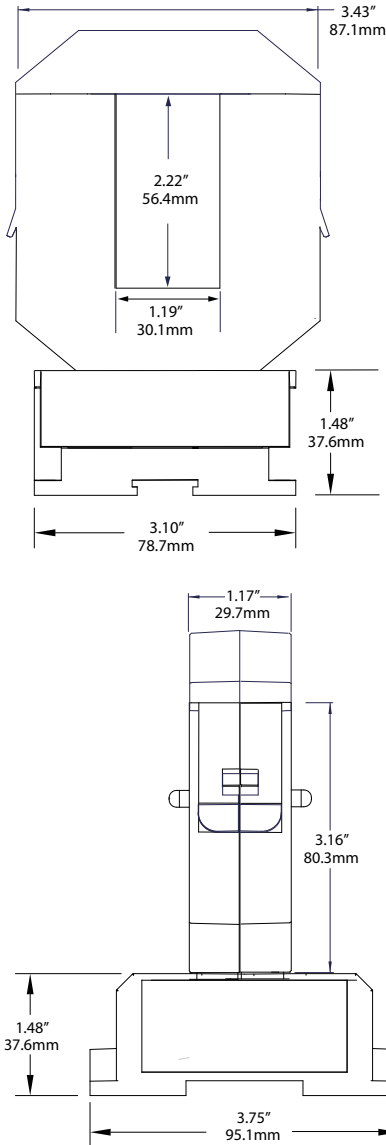

Note: Drawings are not to scale

AC Current Transducer Connections

Single Transducer Installation

Standard Connection

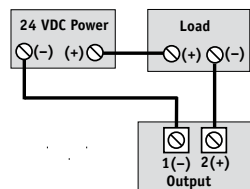

Alternate Connection

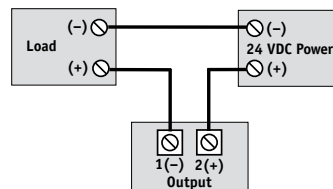

AC Current Transducer Specifications



<b>Power Supply</b>	24 VDC nominal (12–32 VDC)
<b>Output Signal</b>	4–20 mA loop-powered, average or True RMS
<b>Output Limit</b>	23 mA
<b>Output Impedance</b>	<750 Ω @ 24 VDC
<b>Accuracy</b>	1.0% from 10–100% of range
<b>Response Time</b>	600 ms (90% step change)
<b>Range</b>	2: 0–200 A 4: 0–400 A 6: 0–600 A 8: 0–800 A
<b>Frequency Range</b>	• AT: 50/60 Hz (average responding) • ATR: 20–400 Hz (True RMS responding)
<b>Isolation Voltage</b>	UL tested to 2000 VAC isolation, monitored conductor to output terminals
<b>Case</b>	UL94 V-0 Flammability Rated
<b>Environmental</b>	-4 to 122°F (-20 to 50°C) 0–95% RH, non-condensing
<b>Listings</b>	UL/cUL, CE

AC Current Transducers

AC Current Transducer Ordering Information

Sample Model Number: ATR6-420-24L-MS  
AC current transducer, 0–600 A range, True RMS output 4–20 mA, loop-powered, medium split-core case, DIN rail mounting.

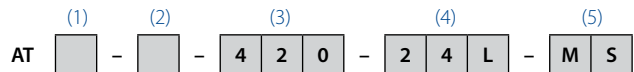

(1) Measurement

	Average responding output signal (blank)
R	True RMS responding output for distorted current

(2) Range

2	0–200 A
4	0–400 A
6	0–600 A
8	0–800 A

(3) Output Type

420	4–20 mA
-----	---------

(4) Power Supply

24L	24 VDC Loop-power (12–32 VDC)
-----	-------------------------------

(5) Case Style

MS	Split-core, base terminals, DIN rail mounting
----	---

