

ATH SERIES

AC Current Transducer with Time Integration

ATH Series (patented) AC Current Transducers are the latest innovation from NK Technologies. Monitoring the current or power controlled by silicon-controlled rectifiers (SCRs) can be a challenge, especially the current used by heaters. When used to monitor zero-crossing (burst) fired SCRs, the ATH will provide an output signal directly proportional to the RMS amperage. Zero-crossing fired controls allow current to flow to the circuit for as short of a time period as one cycle, and off for several cycles. Most current sensors will not work well when there is no current present. This capability is important in case a heating element fails but the process continues operating, which could result in scrapped material.

AC Current Transducer Applications

Electrical Heaters

- Faster response than temperature sensors.
- Simplest method to monitor pulsed waveforms.

Burst-Fired Heating Controls

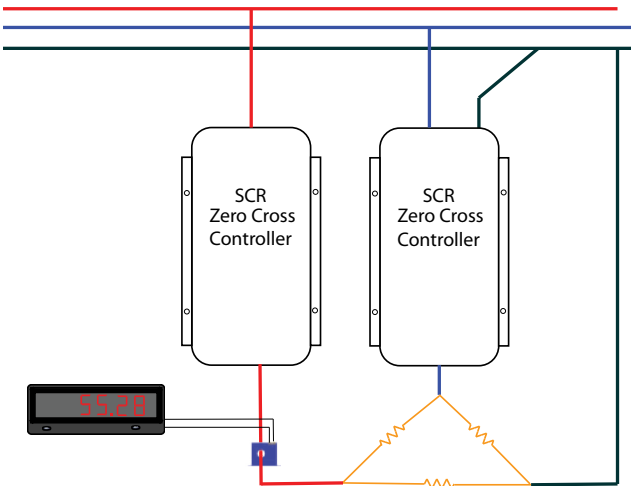

For additional Application Examples, go to www.nktechnologies.com/applications

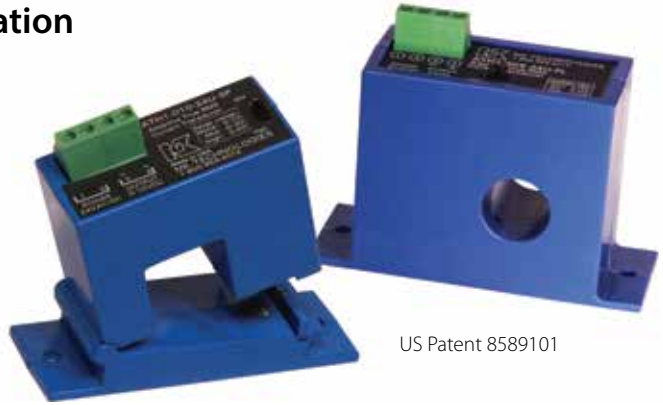

US Patent 8589101

AC Current Transducer Features

Industry Standard Outputs

- 4–20 mA, 0–5 or 0–10 VDC.
- Compatible with most automation systems.

External Powered

- Split-core models available powered with 24 VAC or DC.
- Solid-core models powered with 24 VAC or DC or 120 VAC.

Factory Calibrated

- No need for zero and span adjustment potentiometers.

RMS Output

- Accurate measurement of sinusoidal or pulsed current wave shapes.

Built-in Mounting Feet

- Simple, two-screw panel mounting or attach with DIN rail brackets (included).*

UL/cUL Approved, CE Pending

- Accepted worldwide.

*For information on the DIN rail accessories kit, see page 140.

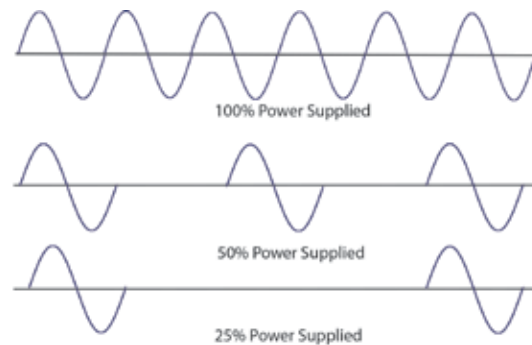

ATH AC current transducers will produce a signal proportional to the current used even when the controller is supplying power in one cycle increments. This is quite common as the “burst-fired” zero crossing switching method produces less harmonic distortion than phase-angle fired controls.

OEMs Test & Evaluation Units for OEMs
Free program expedites evaluation process. See page 3 for details.



AC Current Transducer Dimensions

SP Case

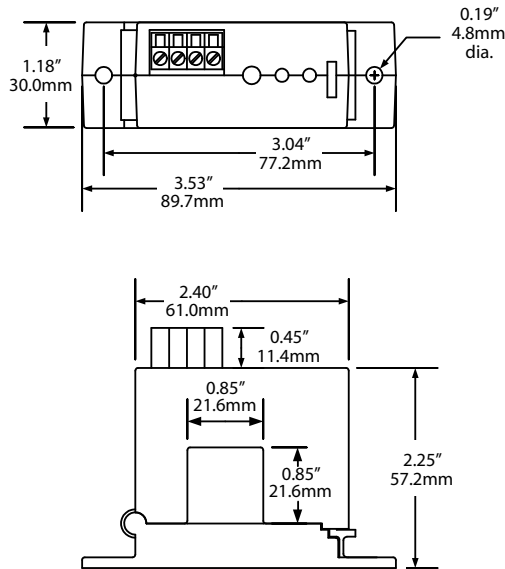

FL Case

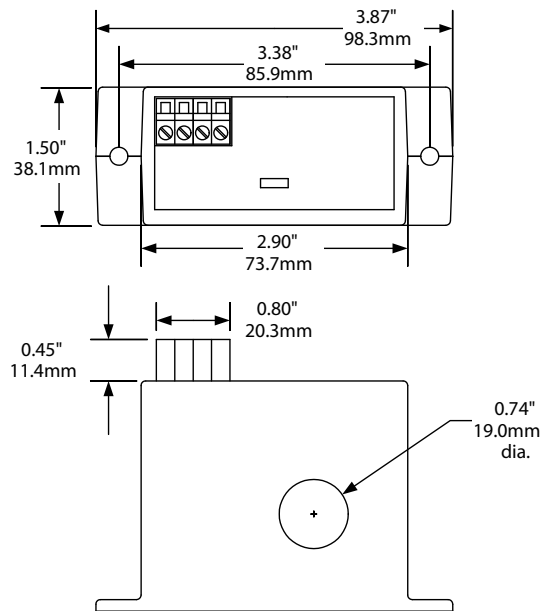

AC Current Transducer Connections

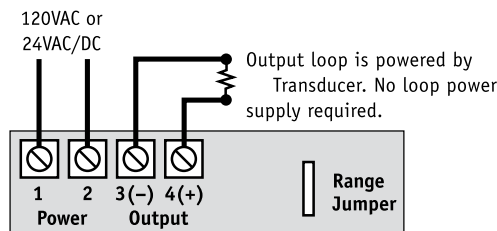

AC Current Transducer Specifications

Power Supply	• 120 VAC (108–132 V) solid-core only • 24 VAC/DC (22–26 V) solid or split-core
Consumption	<2 VA
Output Signal	• 4–20 mA (20 mA maximum) • 0–5 VDC (5 VDC maximum) • 0–10 VDC (10 VDC maximum)
Output Impedance	• 0–5 or 0–10 VDC: 10 K Ω min. • 4–20 mA: 500 Ω max.
Accuracy	1% FS
Response Time	• 600 ms max., 250 ms at 100% power • PWM Cycle Period: 12 ms (minimum), 54 sec (maximum)
Isolation Voltage	UL listed to 1270 VAC, tested to 5 KV
Case	UL94 V-0 Flammability Rated
Environmental	-4 to 122°F (-20 to 50°C) 0–95% RH, non-condensing
Listings	UL/cUL approved, CE pending

AC Current Transducers

AC Current Transducer Ordering Information

Sample Model Number: ATH1-420-24U-SP
AC current transducer, time proportioned, 4-20 mA output, 24 VAC or DC power supply, split-core case. (DIN rail adapters are included)



(1) Range

0	2 and 5 A
1	10, 20 and 50 A
2	100, 150 and 200 A

(2) Output Type

420	4–20 mA
005	0–5 VDC
010	0–10 VDC

(3) Power Supply

24U	24 VAC or DC
120	120 VAC

(4) Case Style

SP	Split-core
FL	Solid-core

