

ATR SERIES

AC Current Transducers

ATR Series AC Current Transducers combine a current transformer and a True RMS signal conditioner into a single package. These current transducers provide True RMS output on distorted waveforms found on VFD or SCR outputs, and on linear loads in “noisy” power environments. The ATR Series AC Current Transducers are available in a solid- or split-core case.



AC Current Transducer Applications

VFD Controlled Loads

- Monitoring VFD output indicates how the motor and attached load are operating.

SCR Controlled Loads

- Accurate measurement of phase angle fired (time proportioned) SCRs.
- Current measurement gives faster response than temperature measurement.

Switching Power Supplies and Electronic Ballasts

- True RMS sensing is the most accurate way to measure power supply or ballast input power.

AC Current Transducer Features

True RMS Output

- True RMS technology is accurate on distorted waveforms like VFD or SCR outputs.

Jumper-selectable Ranges

- Reduces inventory.
- Eliminates zero and span pots.

Isolation

- Output is magnetically isolated from the input for safety.
- Eliminates insertion loss (voltage drop).

UL/cUL and CE Approved

- Accepted worldwide.

Monitoring a Motor Driven with a VFD

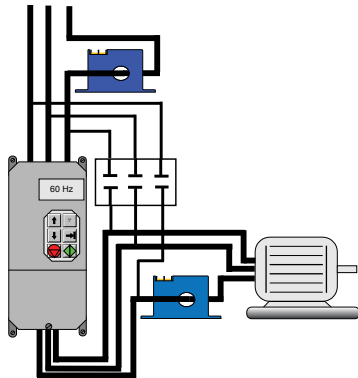

Use the ATR current transducer on the line or load side of the drive and the signal will be accurate in either position.

- For additional Application Examples, go to www.nktechnologies.com/applications

Selecting the right transducer:

The current waveforms of a typical linear load is a pure sine wave. In VFD and phase angle fired SCR applications, however, output waveforms are rough approximations of a sine wave. There are numerous spikes and dips in each cycle. ATR transducers use a mathematical algorithm called “True RMS” which integrates the actual waveforms over time. The output is the amperage component of the true power (heating value) of the AC current waveforms. True RMS is the only way to accurately measure distorted AC waveforms. **Select ATR transducers for nonlinear loads in “noisy” power environments.**

OEMs

Test & Evaluation Units for OEMs

Free program expedites evaluation process. See page 3 for details.

AC Current Transducer Dimensions

FT Case

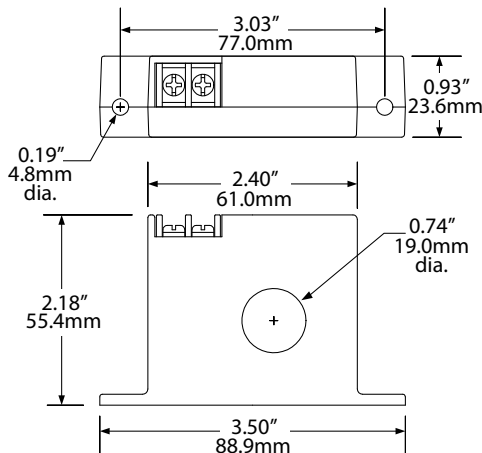

SP Case

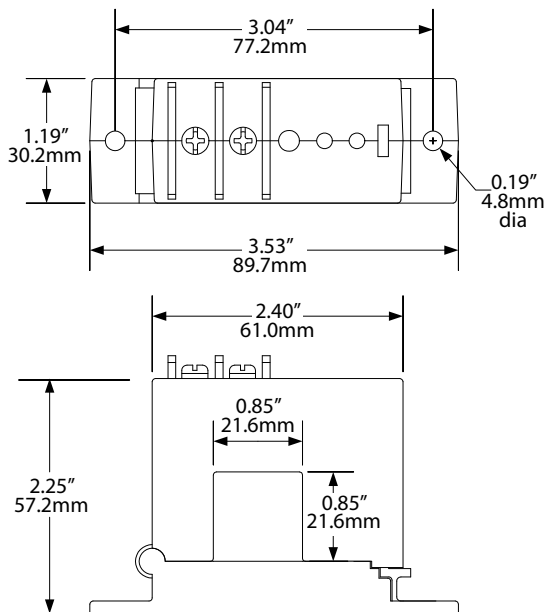

AC Current Transducer Connections

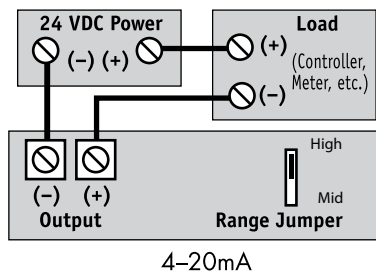

Notes:
 Deadfront captive screw terminals (-SP case).
 12-22 AWG solid or stranded.
 Observe polarity.

AC Current Transducer Specifications



Power Supply	24 VDC (12-40 VDC)
Output Signal	4-20 mA loop-powered, average or True RMS
Output Limit	23 mA
Output Impedance	<750 Ω @ 24 VDC
Accuracy	1.0% FS
Response Time	600 ms (to 90% step change)
Frequency Range	10-400 Hz
Isolation Voltage	UL listed to 1270 VAC, tested to 5 KV
Input Range	0-200 A (adjustable); consult factory for custom ranges
Case	UL94 V-0 Flammability Rated
Environmental	-4 to 122°F (-20 to 50°C) 0-95% RH, non-condensing
Listings	UL/cUL, CE

AC Current Transducers

AC Current Transducer Ordering Information

Sample Model Number: ATR1-420-24L-SP
 True RMS AC current transducer, 10/20/50 A ranges, 4-20 mA output, 24 VDC loop-powered in a split-core case. (DIN rail adapters are included)



(1) Full Scale Range

0	2, 5 A
1	10, 20, 50 A
2	100, 150, 200 A

(2) Output Signal

420	4-20 mA
-----	---------

(3) Power Supply

24L	24 VDC loop-powered (4-20 mA output ONLY)
-----	---

(4) Case Style

FT	Solid-core, top terminals
SP	Split-core

