

H11D

LCD Display



H11D



The Hawkeye TruStat H11D is a microprocessor based, self-learning, self-calibrating current switch. It is designed for user ease, providing calibration-free status for both under and overcurrent, an LCD display, and slide-switch selectable trip point limits. At initial power-up, the H11D automatically learns the average current on the line with no action required by the installer. Once a current is learned, the switch monitors for changes in current greater than the selected range.

SPECIFICATIONS

Sensor Power	Induced from monitored conductor
Response Time	1 sec.
Accuracy	±2% of full scale
Frequency Range	50/60 Hz
Temperature Range	-15 to 60 °C (5 to 140 °F)
Humidity Range	10 to 90% RH non-condensing
LCD Backlight	Off at low currents; illuminates when monitored current exceeds 4.5 A; flashes during an alarm state while current remains above 4.5 A
On-State Resistance	≤1.0 Ω
Off-State Resistance	≥1.0 MΩ
Setpoint Target Range, Switch Setting A ¹	±40% of learned nominal current; max. learned current of 142 A to enable an upper trip limit at or below 200 A
Setpoint Target Range, Switch Setting B ¹	±60% of learned nominal current; max. learned current of 125 A to enable an upper trip limit at or below 200 A
Switch Setting C ¹	On/Off Status; contacts are closed while amperage is above 2.5 A
Alarm Reset Range ²	±5% of learned nominal current
Setpoint Calibration Learn Period	30 sec.; self-learning, pushbutton reset
Normal-to-Alarm Output Delay	1 sec. maximum
Alarm-to-Normal Output Delay	30 sec. nominal

Backlit LCD

View the monitored current (up to 200 A)...no need for expensive handheld meters and offers easy visibility in dark enclosures

Simplified troubleshooting

Records and displays the amperage level that trips the alarm

Microcontroller-based learning technology

Automatically learns load upon initial power-up...minimizes calibration labor

Versatility

Slide-switch selectable trip point limits

Automatic calibration

Reduced errors and installation costs

Reset function

Reset function can be used when unpowered...reduces the possibility of an arc flash incident

APPLICATIONS

- HVAC fans, pumps, and blowers
- Monitoring status of industrial process equipment

Insulation Class	600 Vac RMS (UL); 300 Vac RMS (CE ³)
Hysteresis	10% (typical)
Terminal Block Wire Size	24 to 14 AWG (0.2 to 2.1 mm ²)
Terminal Block Torque	3.5 to 4.4 in-lbs (0.4 to 0.5 N-m)

WARRANTY

Limited Warranty	5 years
------------------	---------

AGENCY APPROVALS

Agency Approvals	UL 508 open device listing; CE: EN61010-1, CAT III, Pollution Degree 2, basic insulation
------------------	------------------------------------------------------------------------------------------



1. Trip point switch positions A and B are not for use in applications where the current will fluctuate by more than 40% (A) or 60% (B) of the nominal current. If the current will fluctuate by more than 60%, use the H11D for on/off status (position C) only.
2. The upper trip limit alarm resets when the current drops by 5% of the learned nominal current limit. The lower trip limit alarm resets when the current rises by 5% of learned nominal current limit.
3. The CE mark indicates RoHS2 compliance. Please refer to the CE Declaration of Conformity for additional details.

Specification Note: For CE compliance, conductor shall be insulated according to IEC 61010-1

Do not use the LCD as evidence of applied voltage.

DIMENSIONAL DRAWING

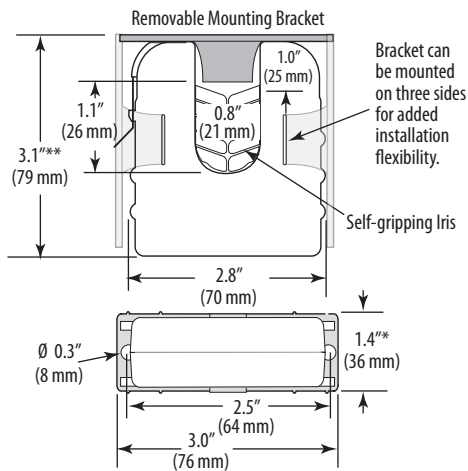

* Terminal block may extend up to 1/8" over the height dimensions shown.

WIRING DIAGRAM

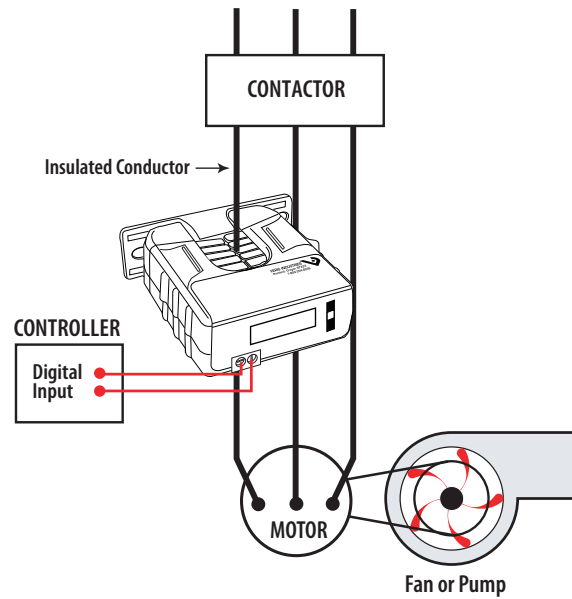

FUNCTIONAL DRAWING

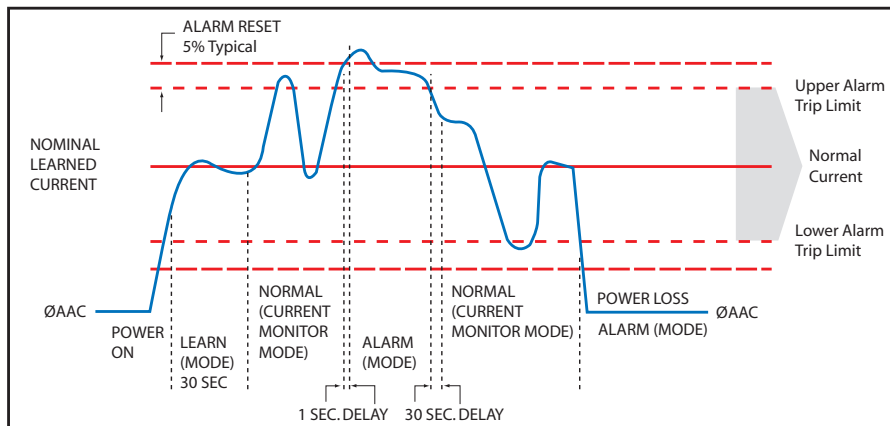

ORDERING INFORMATION

MODEL	AMPERAGE RANGE ¹	STATUS OUTPUT	NOMINAL TRIP POINT TARGET RANGE	HOUSING	STATUS LED	UL	CE
H11D	2.5 to 200 A @ 60 Hz 3.0 to 200 A @ 50 Hz	N.O. 1.0 A @ 30 Vac/dc	±40%, ±60%, or on/off (user selectable)	Split-core	•	• ²	•

1. To enable the upper trip limit alarm, the max. learned current for switch setting "A" is 142 A, and the max. learned current for switch setting "B" is 125 A. Switch setting "C" is for on/off status only, so the upper trip limit alarm does not apply.

2. Listed for use on 75 °C insulated conductors.