

MT300

Three Channel Temperature Monitor User Manual

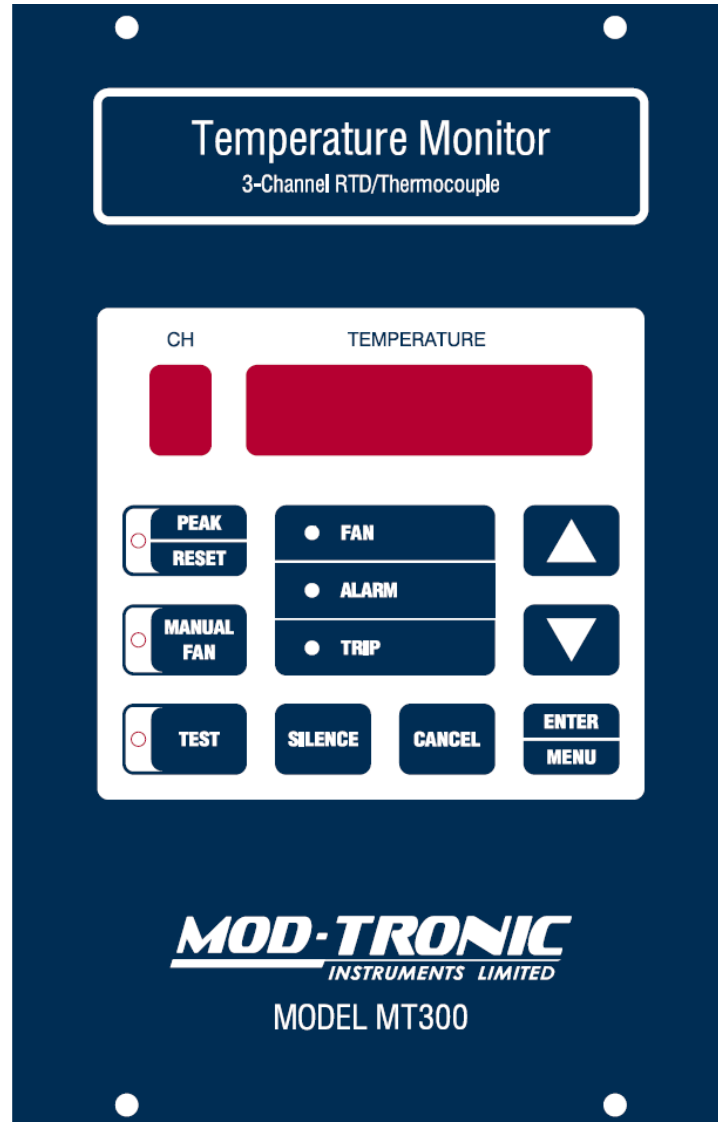

Table of Contents

1	Introduction	4
2	Conventions	4
3	Installation	5
3.1	Mounting	5
3.2	Wiring	6
3.2.1	Controller Power	7
3.2.2	Inputs	7
3.2.3	Outputs	8
3.2.4	Serial Communication	9
4	Configuration	10
4.1	Non-Volatile Configuration Storage	10
4.2	Primary Configuration	10
4.2.1	<i>INPUTS</i>	12
4.2.2	<i>OFFSET</i>	12
4.2.3	<i>SCALE</i>	12
4.2.4	<i>CHdI SP</i>	12
4.2.5	<i>4-20</i>	13
4.2.6	<i>SILEnt</i>	14
4.2.7	<i>l t r I P A</i> through <i>3 t r I P C</i>	14
4.2.8	<i>SERIAL</i>	16
4.2.9	<i>FAn EH</i>	17
4.2.10	<i>FAn t0</i>	17
4.2.11	<i>rA rLY</i>	17
4.2.12	<i>brI tE</i>	18
4.2.13	<i>PASS</i>	18
4.2.14	<i>rESEt</i>	19
4.3	Secondary Configuration	19
4.3.1	<i>l t r I P A</i> through <i>3 t r I P C</i>	19
5	General Usage	20
5.1	Operation Modes	20
5.1.1	Monitoring Mode	20
5.1.2	Peak Display Mode	21

5.1.3	Setup Mode.....	22
5.1.4	Test Mode	22
5.2	Access Restrictions	22
5.3	Special Functions.....	24
5.3.1	Recovery.....	24
5.3.2	Error Reporting	24
5.3.3	USB Reset	24
6	MODBUS	25
6.1	Holding Registers.....	25
6.2	Input Registers.....	28
6.3	Value Format Key	29
7	Specifications	37
7.1	Inputs.....	37
7.1.1	Power	37
7.1.2	Sensors	37
7.2	Outputs.....	37
7.2.1	4-20mA loop.....	37
7.2.2	Relays	37
7.3	Communication	38
7.3.1	RS-485	38
7.3.2	USB	38
7.4	General.....	38
7.4.1	Accuracy	38
7.4.2	Dimensions.....	38
7.4.3	Weight.....	38
7.4.4	Environmental.....	38
7.4.5	Construction.....	38
7.4.6	Approvals	38
7.4.7	Factory Defaults	38
8	Glossary.....	39
9	Change Log.....	39

1 Introduction

The CT424 is a universal, three-channel temperature monitor capable of utilizing any combination of the supported sensor types. Three relay outputs and an internal buzzer are individually configurable to be tripped by one or more sensor inputs. The included 4-20mA output is fully configurable and may be loop powered or internally powered. An RS-485 interface and USB port use the MODBUS protocol to configure the unit as well as read the configuration, sensor values, and peak values. However, all configuration and available values are accessible via the intuitive front panel interface. Celsius and Fahrenheit scales are supported.

Separate electrical isolation is provided on the 4-20mA loop, RS-485, and sensor inputs for compatibility with a wide range of installation environments.

2 Conventions

Several different typstyles are used throughout this manual to make it easier to convey whether the text refers to a button, indicator, numeric display, output, etc.

In general, if a word or phrase is in all caps (LIKE THIS) it means that it refers to the name of a button or single LED indicator on the CT424 front panel. Exceptions to this are acronyms such as USB and MODBUS.

If a word or phrase is first letter capitalized (Like This) it means that it refers to the name of a feature, such as Fan Exerciser, or an input or output, such as Channel 1 or Fan Relay.

If a word or phrase is in an LED display font (**LI HE THI 5**) it means that it refers to something displayed on the numeric display.

If a value is preceded by "0x", that value is in hexadecimal; other numbers should be assumed to be decimal.

The usage of the words "alarm" and "trip", in particular, regardless of capitalization, could be confusing. These two words are industry standard terms for relay outputs on products such as the CT424.

Alarm could refer to the Alarm Relay output, front panel ALARM indicator, or the audible alarm (Buzzer). However, when referring to the relay output, it is explicitly written as such. When referring to the front panel indicator, capitalization will be used as previously described to prevent confusion.

Trip can refer to the Trip Relay output, the front panel TRIP indicator, the action of a setpoint being exceeded, or describing the group of settings that determine a setpoint, and what happens when that setpoint is exceeded, which is referred to as "trip settings". Again, the previously described convention will be used to clarify the intended meaning.

Because of the Reverse Acting Relay feature, specific terms are used to indicate whether a relay's coil is actually powered, or if that relay output is in the trip state regardless of the Reverse Acting Relay settings. If referring to whether a relay's coil is powered, "energize" will be used. If referring to if a relay output is in the trip state, "engage" will be used.

If a relay output is engaged, the associated front panel LED will light, however, whether the relay is energized will depend on the Reverse Acting Relay settings.

3 Installation

There are no jumpers or user-accessible connections inside the CT424. Instead, it is suggested that the user determines whether the C or F scale is preferred and set this before further configuration since the CT424 will not convert existing settings when the scale is changed.

3.1 Mounting

The CT424 should be installed in a rectangular cutout of dimensions 5.6" x 9.0", or 142mm x 229mm. The dimensions of the CT424 are shown in [Figure 1](#) for reference. It's easiest to place the CT424 in the cutout, then mark or directly drill the screw mount holes.

The mounting screws/bolts should be tight enough to compress the foam gasket so as to prevent debris from entering behind the CT424.

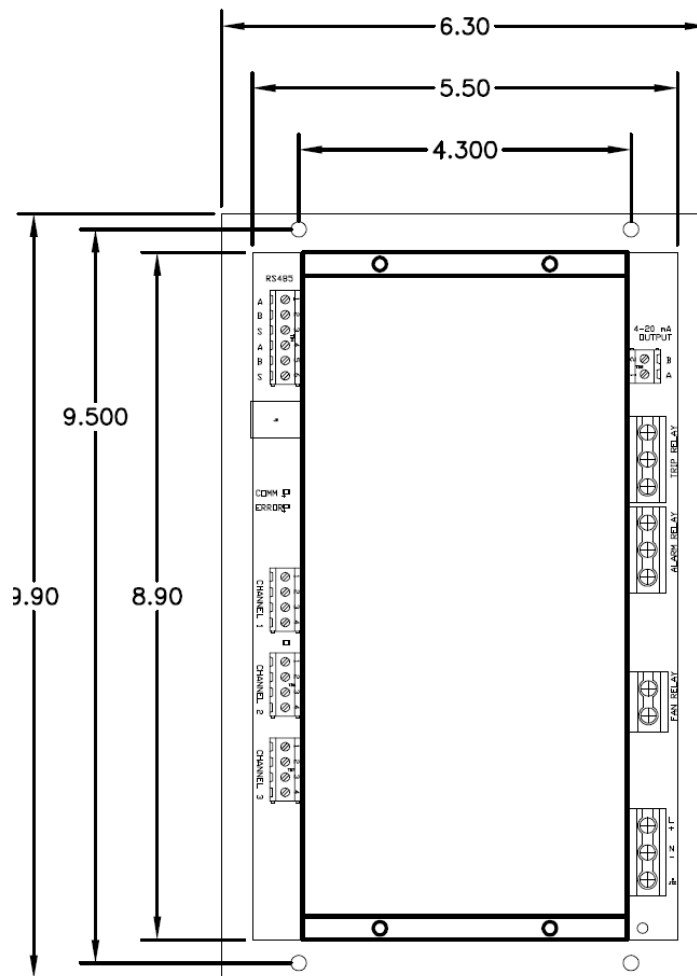

Figure 1

3.2 Wiring

The rear panel is shown in [Figure 2](#) and provides a visual guide of the terminal block connections. Each connection is detailed in following sections.

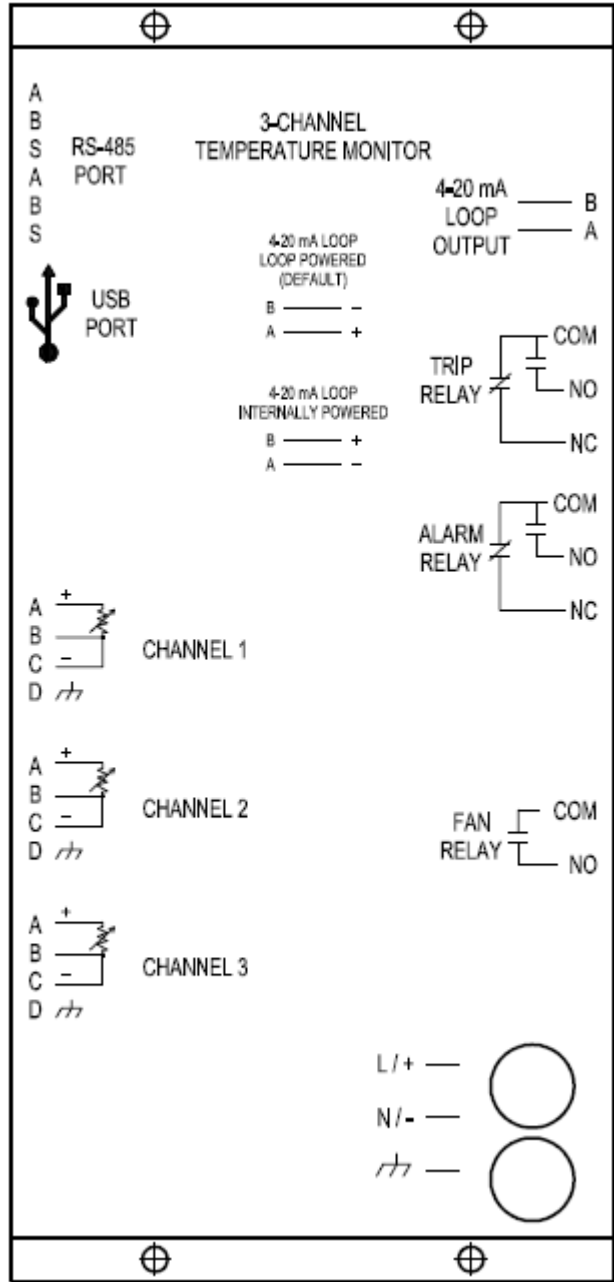

Figure 2

3.2.1 Controller Power

The CT424 is available in AC and DC models. While the external connections appear identical, care must be taken to properly connect the appropriate power supply.

The power input for both the AC and DC model is electrically isolated from the rest of the CT424 circuitry.

3.2.1.1 AC Model

On AC models, the line and neutral must be connected to the L/+ and N/- terminals, respectively. The remaining connection is earth ground. It is **imperative** that the earth ground terminal be properly connected. While the unit will function without it, failure to do so is a potential shock hazard, may cause reduced performance, and puts the CT424 at risk for damage due to ESD and consequently will void the warranty.

3.2.1.2 DC Model

On DC models, the positive and negative must be connected to the L/+ and N/- terminals, respectively. As with the AC model, the remaining connection is earth ground, and it is **imperative** that the earth ground terminal be properly connected. While the unit will function without it, failure to do so is a potential shock hazard, may cause reduced performance, and puts the CT424 at risk for damage due to ESD and consequently will void the warranty.

3.2.2 Inputs

The CT424 can use any combination of supported sensors which are listed in [7.1.2](#).

The sensor inputs are collectively isolated from the rest of the device, but are **not** isolated from each other. Therefore, care must be taken to not create a situation where a voltage differential can occur between sensors. This is generally an issue only if grounded thermocouples are used since most RTDs are electrically isolated from the sensor casing.

Each sensor channel has four terminals. Terminals A through C are sensor inputs, and terminal D is an earth ground connection for sensor lead wire shields. In general, shielded and twisted pair sensor wires are the best for electrically noisy environments. In addition, RTDs are generally more immune to noise than thermocouples, and offer better accuracy.

If a shield is provided on a sensor lead, it should be grounded at only one end for best performance. Which end to ground is usually determined through trial and error since otherwise it is extremely difficult to determine. Terminal D is provided for this purpose if the sensor is grounded at the CT424 end.

3.2.2.1 RTDs

Either two-wire or three-wire RTDs may be used. Using three-wire RTDs will allow the CT424 to automatically compensate for wire resistance as long as all three wires have the same resistance (i.e. same wire gauge and length).

When using two-wire RTDs, connect terminals B and C together with a short jumper, then connect the RTD to terminal A and the junction of B and C. Be aware that the lead wire resistance on a two wire RTD will be included in the measurement, and therefore, will be less accurate.

When using three-wire RTDs, the uniquely colored wire is usually the one to connect to terminal A, and the remaining two similar colored wires should be connected to terminals B and C. If in doubt, an ohmmeter may be used to determine which two sensor wires are connected together at the sensor end. These are the wires that should connect to terminals B and C.

3.2.2.2 Thermocouples

The thermocouple's positive lead should be connected to terminal A, and the negative lead should be connected to terminal C. Generally the negative wire on a thermocouple is red. Terminal B must remain unconnected.

3.2.3 Outputs

3.2.3.1 Relays

Three relay outputs are available: two SPDT relays and one SPST relay. It should be noted that although the relays have specific names, the function of each relay is fully programmable with the exception of the Fan relay, which in addition is permanently linked to the MANUAL FAN button and the Fan Exerciser.

The terminal assignments are indicated on the rear cover of the unit; COM = Common, NO = Normally Open, and NC = Normally Closed.

3.2.3.2 4 – 20mA Loop

A 4 – 20 mA output is provided on the CT424. This output will pass a current between 4 and 20 mA to represent one of the sensor inputs. The output will fall as low as 3.8mA or as high as 21mA during normal operation in which the loop output has reached beyond the range defined by the user. The output may also fall to either 3.5mA or 23mA to indicate a sensor out of range.

The loop may be configured to be external loop-powered or powered by the CT424.

The loop output is electrically isolated from the rest of the CT424 **except** when internal loop power is selected. When internal loop power is selected, it is electrically connected to the power supply of the CT424, and therefore electrically connected to the USB port, while other terminals on the CT424 remain electrically isolated from the loop.

In environments harboring a high amount of EMI or electrical interference, the 4-20mA loop cable will need to be wrapped around a ferrite to meet the stated loop accuracy. This ferrite is generally required only if the 4-20mA loop is used and is in very close proximity to devices generating a high amount of EMI (such as motors and radio transmitters). An indication this ferrite is required would be if the 4-20mA output fluctuates wildly. If the 4-20mA loop output is stable, there is no need to add anything. Please contact MOD-TRONIC if you believe you require this part and one will be provided free of charge.

For reference, the recommended part is Würth Elektronik 7427153.

3.2.4 Serial Communication

The CT424 includes an RS-485 and USB interface, both of which communicate using the MODBUS protocol. Either interface may be chosen to communicate with the unit, but both cannot be used simultaneously. Both interfaces accept the same commands and have access to the same registers, but USB will typically be used for an easy connection to a computer, while RS-485 will typically be used when multiple MODBUS devices must be connected in a network, when other standalone MODBUS devices communicate with the CT424, or when long bus length is required.

Two LEDs are located near the USB jack; one is labeled COMM and the other is labeled ERROR. The COMM LED will blink when the selected interface, RS-485 or USB, is sending or receiving data. This LED will blink when the selected interface receives anything, including invalid data. The ERROR LED will blink if the CT424 receives a valid MODBUS message with a function code that isn't supported by the CT424.

3.2.4.1 RS-485

RS-485 is a differential signaling method that provides high reliability over long distances and multiple devices on a single network, over a single twisted pair. The CT424 has two identical sets of terminals for RS-485 connections, each set containing terminals A, B, and S. Both "A" terminals are electrically identical and are the non-inverting connections, while both "B" terminals are electrically identical and are the inverting connections. The "S" terminals are also electrically identical and are for the cable shield which should be connected in **one** location only. A 120Ω termination resistor will typically be connected across terminals A and B in each end device in an RS-485 network.

A MODBUS slave ID and baud rate must be selected in the configuration before the RS-485 interface can be used.

The RS-485 interface is electrically isolated from other CT424 circuitry.

3.2.4.2 USB

The USB interface provides a quick and convenient method of connecting the CT424 to a computer when an RS-485 interface is not available. The commands and capability are identical to the RS-485 interface; the USB interface appears as a COM port to Windows so it may be possible to use some third-party Windows RS-485 applications with USB.

In order to use the USB interface, a MODBUS slave ID must be selected and the baud rate must be set to “**USB**”. The Windows application must be set to the COM port assigned to the USB connection, baud rate set to 19.2K, and no flow control.

The USB interface is not electrically isolated.

The Windows driver is on the included CD under “MCP2200\Driver Installation Tool”. From there, choose “x86” or “x64” depending on if your Windows installation is 32 bit or 64 bit, respectively.

4 Configuration

To configure the CT424, Configuration Mode must be entered. To do this, press and hold the ENTER/MENU button. If no password is set, the Primary Configuration will immediately be presented and the first menu option, **I nPUTS**, will be displayed. Otherwise, if at least the Primary Password is set, the CT424 will ask for the password by displaying **0_ _ _**. Use the UP and DOWN buttons to change the first digit to the desired number, and then press ENTER/MENU to accept and move to the next digit. Continue until all four digits have been set.

If the entered password does not match either the Primary or Secondary Password, **dEnI Ed** will momentarily display and will revert back to Monitoring Mode. If the entered password matches the Primary Password, access to the Primary Configuration will be granted; all configuration settings will be available. The first menu option, **I nPUTS**, will be initially displayed. (Note: the front panel TEST button is protected by the Primary Password)

If the entered password matches the Secondary Password, access to the Secondary Configuration will be granted; only the trip setpoints will be available. In this case the first menu option of the “setpoint-only menu”, **I tRIP A**, will be initially displayed.

Should the user set the Primary Password and the Secondary Password to the same code, the CT424 will behave as if the Secondary Password is disabled (i.e. set to **0000**).

4.1 Non-Volatile Configuration Storage

All configuration settings are stored to non-volatile memory at the point of exiting Configuration Mode. When power to the CT424 is lost, or a reset occurs, the configuration is kept intact.

4.2 Primary Configuration

Use the UP and DOWN buttons to cycle through the base menu options, then use the ENTER/MENU button to select. The specifics of each base menu option are detailed in the following sections. See [Figure 3](#) for the list and order of the base menu options.

CANCEL may be pressed at any time to back up one menu level at a time. Once a specific setting is confirmed with the ENTER/MENU button, it is saved and the user may press CANCEL to drop back a menu level, or pressed repeatedly until the CT424 exits Setup Mode.

If no buttons are pressed while in Setup mode for two minutes, Setup will automatically exit. Any changes made will be saved. The automatic exit function simulates a press of the CANCEL button.

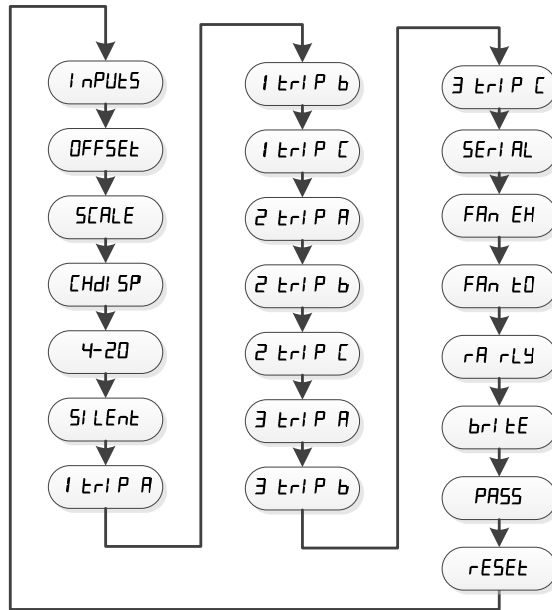

Figure 3

4.2.1 INPUTS

This is used to set sensor types. Initially Channel 1 will be displayed, as indicated by **1** on the left digit, followed by the sensor type which may be **OFF**, **Plt 100**, **Plt 1000**, **EC CA**, or **EC E**, which corresponds to sensor off, platinum 100Ω, platinum 1000Ω, thermocouple type K, and thermocouple type E, respectively. Press the UP and DOWN buttons to cycle through the sensor types until the appropriate one is displayed, then press ENTER/MENU to confirm. Channel 2 will then be displayed, and the process is repeated until all three channels have been set. After Channel 3, the display will revert to the base menu list.

4.2.2 OFFSET

This sets an optional offset to the measured temperature of each channel. Initially Channel 1 will be displayed, as indicated by **1** on the left digit, followed by the offset value. Press the UP and DOWN buttons to change the offset, then press ENTER/MENU to confirm. Channel 2 will then be displayed, and the process is repeated until all three channels have been set. After Channel 3, the display will revert to the base menu list.

Applying an offset may be useful to compensate for a sensor offset, or in effect, change multiple setpoints by only changing the offset value.

It is possible to measure temperatures beyond the CT424's specified range by applying an offset since only the displayed temperature is prevented from exceeding the rated range, however, accuracy in this case is not guaranteed.

4.2.3 SCALE

This sets the scale to Celsius or Fahrenheit. Celsius is represented as **C**, and Fahrenheit as **F**. Once ENTER/MENU is pressed to confirm the setting, the display reverts to the base menu list. It is suggested the user determines whether the C or F scale is preferred and set this before further configuration since the CT424 will not convert existing settings when the scale is changed.

4.2.4 CHdI SP

This sets the channel display mode to one of the four modes as described below. Press the UP and DOWN buttons to cycle through the modes and press ENTER/MENU to confirm the setting. The display then reverts to the base menu list.

HI – The highest temperature channel is displayed. Invalid sensor inputs are ignored. If all three sensor inputs are invalid or disabled, **nD CH** will be displayed.

LO – The lowest temperature channel is displayed. Invalid sensor inputs are ignored. If all three sensor inputs are invalid or disabled, **nD CH** will be displayed.

Any – The displayed channel is selected during Monitor mode with the UP and DOWN buttons. Any sensor inputs that are invalid will display a series of dashes in place of the temperature. Channel **C** is the CJC and this is the only way to view it.

CYCLE – The active (not set to **OFF**) sensor inputs and the maximum stored peak temperature across all channels are automatically cycled every five seconds. The displayed channel is shown on the left digit, while the maximum is represented by an overscore character. If all three sensor inputs are disabled, **nD CH** will be displayed.

4.2.5 4-20

This sets the 4-20 loop output parameters. There are four settings contained within this base menu option: loop power, source, zero level, and span. [Figure 4](#) outlines each of these settings. The UP and DOWN buttons are used to select the desired setting, then ENTER/MENU is used to save that setting and move to the next set. Once the final setting, span, is set, the display reverts to the base menu.

Each of the four settings is described below in the order they are presented on the CT424:

Loop power – **Int** causes the CT424 to power the 4-20 loop internally, while **LOOP** relies on an external power source. Keep in mind that when using the **Int** setting, the 4-20mA loop is no longer electrically isolated.

Source – How the loop will derive its output value. **LO** will cause the loop to output the lowest valid sensor channel. **HI** will cause the loop to output the highest valid sensor channel. The remaining options, **CH1**, **CH2**, **CH3**, cause the loop to output the respective channel.

Zero – The temperature which will cause the loop to output the minimum of 4mA. The leftmost digit will display **0** as a hint that the setting is the zero setting.

Span – The number of degrees represented by the full range of the loop. The adjustable range available is dependent upon the zero setting so as to prevent zero/span combinations that could fall out of range. The leftmost digit will display **5** as an indication that the setting is the span setting.

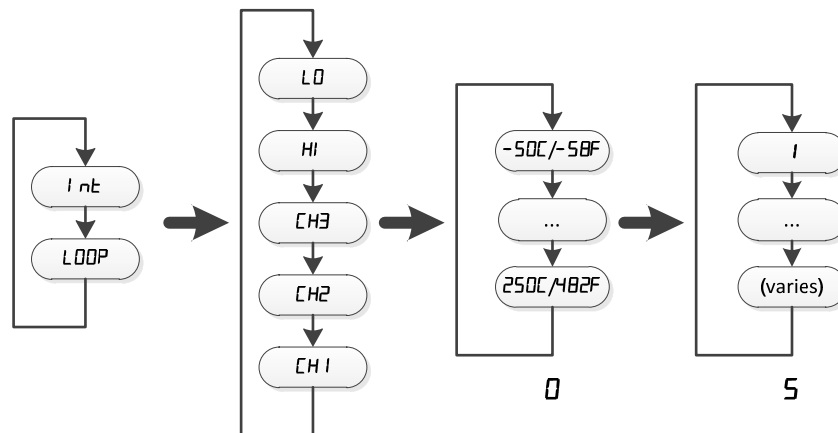

Figure 4

4.2.6 *SILENt*

This setting determines the amount of time, in minutes, the Buzzer remains silenced after *SILENCE* is pressed. Use UP and DOWN to adjust the value. It may also be disabled, indicated by *dI SAbl*, which means the Buzzer will remain silenced indefinitely until another trip occurs.

Once the desired timeout is displayed, press ENTER/MENU. The display then reverts to the base menu.

4.2.7 *1 tRIP A through 3 tRIP C*

These nine base menu options are identical except for the channel they represent. The first character indicates what channel the associated settings apply to, and the last character is a sequence identifier since each channel has three identical trip settings. For example,

1 tRIP A, *1 tRIP b*, and *1 tRIP C* all contain an identical set of options for Channel 1. The three trip settings for each channel allow different events to occur at different temperatures - for example, engaging the Fan Relay when the temperature exceeds 100C, Alarm Relay and Trip Relay when it exceeds 110C, and the Buzzer when it exceeds 120C.

Figure 5 illustrates the sequence of options for each trip setting. The character below each setting, if shown, is the character that is shown on the leftmost digit on the CT424. This character helps the user remember what each setting is, otherwise would be difficult to distinguish from others. These characters and their meanings are given, in order of display on the CT424, in Table 1. The two settings that do not have this are *DuEr / UndEr*, and *CAnCEL / hYSL*. The former determines if the sensor temperature must be higher or lower than the setpoint, respectively, to cause a trip. The latter determines whether the CANCEL button must be used to cancel a trip, or if a hysteresis value will cancel a trip, respectively. When in Monitor Mode, the CANCEL button may be pressed to cancel all trips for the currently displayed channel regardless of the *CAnCEL / hYSL* setting. If the condition that caused the trip(s) still exists, pressing CANCEL will not cancel the trip; the trip will essentially reoccur immediately.

If the *hYSL* setting is used, a hysteresis value may be set by the user and this will allow the CT424 to automatically cancel a trip. If *DuEr* is used, the trip will occur when the setpoint is exceeded as previously explained, however the trip will now cancel itself if the sensor temperature falls below the setpoint by the hysteresis value. For example, if the setpoint is 100C and hysteresis 10C, it automatically cancels the trip if it falls below 100C – 10C = 90C.

If *UndEr* is used, the hysteresis operates in the opposite fashion.

EXAMPLE:

The user would like to engage the Fan Relay if Channel 1 exceeds 100C, and also engage the Buzzer if Channel 1 exceeds 120C. Both the Fan Relay and Buzzer should disengage if Channel 1 temperature falls below 90C.

In addition, the Trip Relay and Alarm Relay should engage if Channel 2 falls under OC, and do not disengage the Trip relay unless the user cancels the trip manually.

Since the user would like to act on two different temperatures for Channel 1, two trip settings must be set. *1 tRIP A*, *1 tRIP b*, and *1 tRIP C* can be used for this purpose. It doesn't matter which two are used, but the unused trip setting should be disabled. For simplicity, this example will use A and B, and disable C.

For *1 tRIP A*, *S* (see Table 1), should be enabled since this trip setting will be used. The Fan should be enabled, Setpoint set to 100, *DUER* rather than *UndEr*, *hYSt* should be used rather than *CAnCEL*, and Hysteresis set to 10.

For *1 tRIP b*, *S* should be enabled since this trip setting will be used. The Buzzer should be enabled, Setpoint set to 120, *DUER* rather than *UndEr*. *hYSt* should be used rather than *CAnCEL*, and set Hysteresis set to 30.

For *1 tRIP C*, *S* should be disabled since this trip is not used.

For the Channel 2 trip, *2 tRIP A* will be used, although *2 tRIP b* or *2 tRIP C* could just as well be used. *2 tRIP b* and *2 tRIP C* should be disabled since they aren't used in this example.

For *2 tRIP A*, *S* should be enabled since this trip setting will be used. The Trip Relay should be enabled, the Alarm Relay should be enabled, Setpoint set to *0*, and *UndEr* rather than *DUER*. *CAnCEL* should be used rather than *hYSt* so Hysteresis cannot disengage the trip, but rather will require the user to press CANCEL.

Character	Meaning
<i>S</i>	Set: Trip setting enable or disable. Setting to disable deactivates that trip configuration, and prevents the rest of the trip settings from appearing.
<i>E</i>	Error: Trip on sensor error.
<i>F</i>	Fan: Engage Fan relay on trip.
<i>A</i>	Alarm: Engage Alarm relay on trip.
<i>t</i>	Trip: Engage Trip Relay on trip.
<i>b</i>	Buzzer: Engage Buzzer on trip.
<i>S</i>	Setpoint: Trip setpoint.
<i>H</i>	Hysteresis: Hysteresis for automatic trip cancel.

Table 1

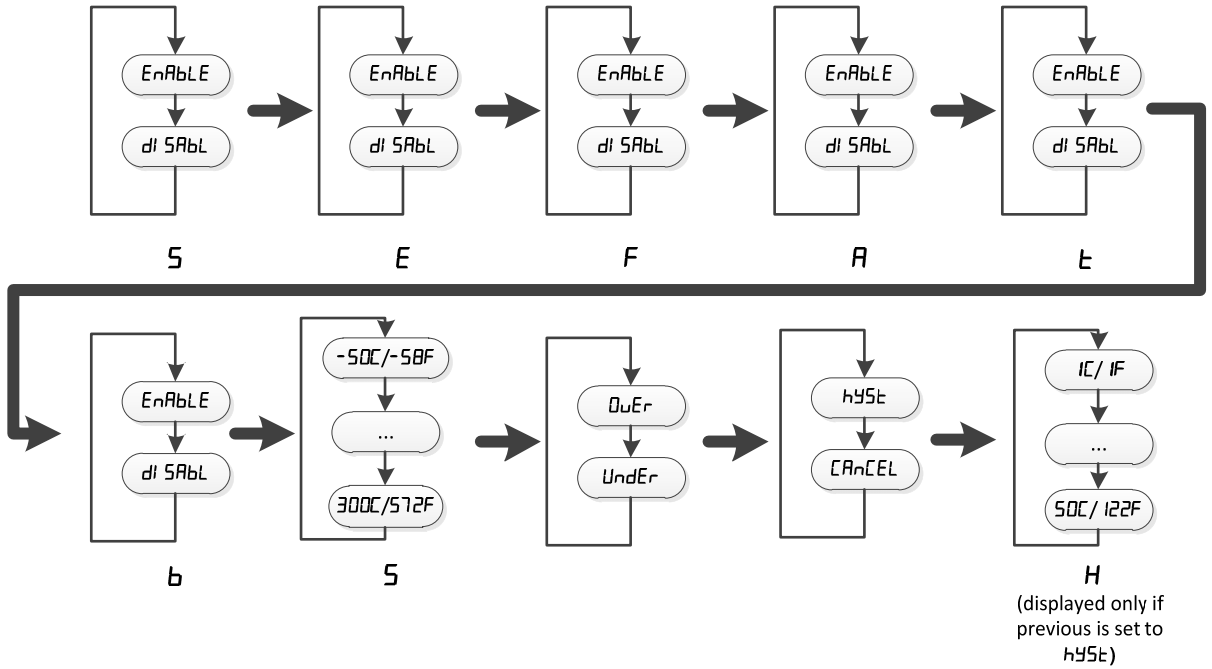

Figure 5

4.2.8 SERIAL

This configures the MODBUS serial communications. The first option sets the slave ID of the CT424. Use UP and DOWN buttons to change the ID, and ENTER/MENU to confirm the desired ID. The second option sets the bitrate for RS-485, or alternately, selects USB. USB and RS-485 cannot be used simultaneously; if a bitrate is selected, that enables RS-485 for use and disables USB.

The sequence of the settings for serial communication is shown in [Figure 6](#).

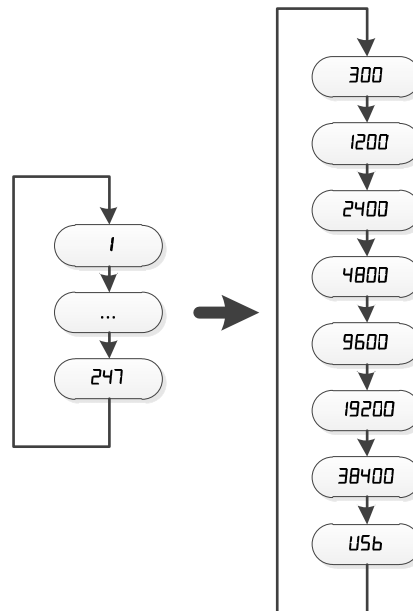

Figure 6

4.2.9 *FAn EH*

This sets up the Fan Exerciser. The first setting is for the Period, which is the number of days between Fan Relay activations. The second setting is the Duration, which is the number of minutes the Fan Relay remains engaged. If Period is set to **dl SAbL**, the Duration will not appear and Fan Exerciser is disabled.

The FAN LED will blink while Fan Exerciser is active.

The sequence of the settings for Fan Exerciser is shown in [Figure 7](#).

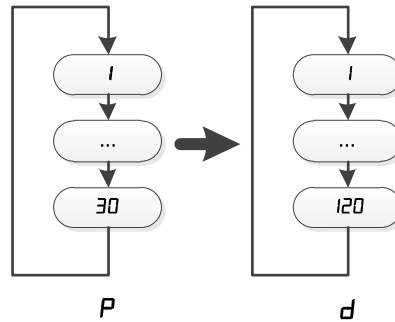

Figure 7

4.2.10 *FAn tD*

This sets the Manual Fan timeout. This setting is a single number that determines the number of minutes the Manual Fan will remain engaged before automatically disengaging. If the setting is set to **dl SAbL**, only pressing the MANUAL FAN button will disengage it.

4.2.11 *rA rLY*

This enables or disables the Reverse Acting feature for each of the three relay outputs. Normally, activating an output (such as when a setpoint is exceeded or when the Manual Fan is turned on) causes the relay coil to energize and connects the “common” terminal to the “normally open” terminal. Change the setting from **dl SAbL** to **EnAbLE** in order to cause the respective relay to operate in the reverse fashion. The order of options presented is shown in [Figure 8](#). **F**, **A**, and **t** represent Fan, Alarm, and Trip, respectively. Note that this setting affects only the relays; the front panel FAN, ALARM, and TRIP indicators will continue to behave the same.

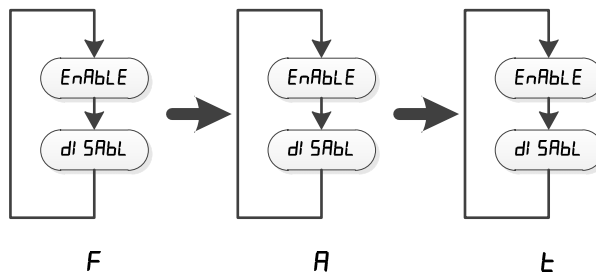

Figure 8

4.2.12 *bri tE*

This setting controls the brightness of the digital display. When this setting is selected by pressing ENTER/MENU, *AdJUST* will be displayed. Use the UP and DOWN buttons to adjust the display brightness. Three levels are provided. When the desired brightness is set, press ENTER/MENU. The base menu will then reappear.

It should be noted that the front and rear panel indicators are not affected. Only the 7-segment displays can be adjusted.

4.2.13 *PASS*

When this menu option is selected, *P 0 _ _ _* will be displayed, which is the prompt to enter a new Primary Password. Use the UP and DOWN buttons to change the first digit to the desired number, then press ENTER/MENU to accept and move to the next digit. Continue until all four digits have been set.

After the last digit is set and ENTER/MENU is pressed, the menu will prompt to set the Secondary Password if the Primary Password was set to a non-zero number. In this case, *S 0 _ _ _* will be displayed and the same procedure as setting the Primary Password should be used.

However, if the Primary Password is set to *0000*, both the Primary and the Secondary Password will automatically be disabled; therefore the CT424 will not prompt for the Secondary Password. See [Figure 9](#) for the sequence of settings shown for this configuration.

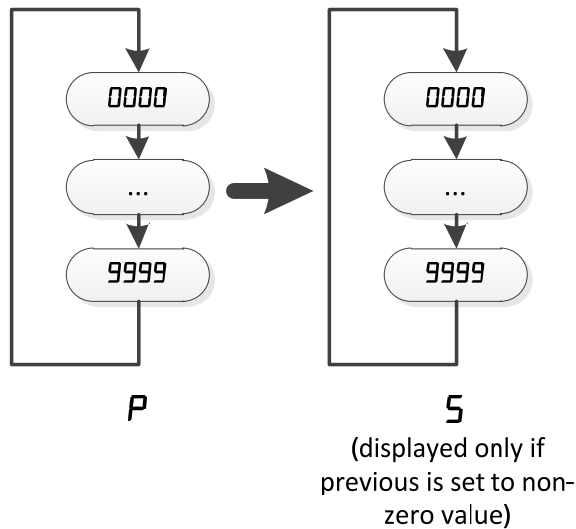

Figure 9

4.2.14 *rESEt*

This sets the CT424 to factory defaults. If ENTER/MENU is pressed while this option is selected, *rESEt?* (reset?) will be displayed in order to make sure the user really wants to continue. Press ENTER/MENU to confirm the reset. A progress indicator will be displayed, followed by *dOnE*. The base menu will then be displayed.

The factory default listing is in [7.4.7](#).

4.3 Secondary Configuration

Use the UP and DOWN buttons to cycle through the base menu options, then use the ENTER/MENU button to select. The specifics of each base menu option are detailed in the following section. See [Figure 10](#) for the list and order of the base menu options.

CANCEL may be pressed at any time to back up one menu level at a time. Once a specific setting is confirmed with the ENTER/MENU button, it is saved and the user may completely back out of Setup Mode by pressing CANCEL.

If no buttons are pressed while in Setup mode for two minutes, Setup will automatically revert back to Monitor mode. Any changes that were made will be saved.

4.3.1 *1 tRIP A through 3 tRIP C*

These settings, being part of the Secondary Configuration, allow changes to each trip's setpoint only. Pressing ENTER/MENU on any of the nine options will display and allow the user to change only the setpoint for that trip. Use UP and DOWN to change the setpoint, then press ENTER/MENU to confirm the value. The display will return to the base menu.

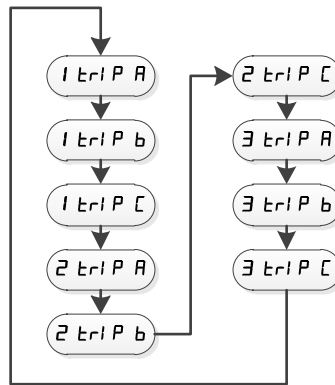

Figure 10

5 General Usage

This section contains information about using the CT424 once it has been configured.

5.1 Operation Modes

The CT424 has four modes of operation. Three of them are considered main modes of operation and the remaining one is actually a sub-mode; Monitoring Mode, Setup Mode, and Test Mode are the three main modes. Monitoring Mode is the normal running mode in which sensors and trip points are monitored and acted upon, and is the mode that the CT424 will normally enter upon applying power. Setup Mode is used when configuring the unit; sensor inputs are not monitored when in this mode. In Test Mode, sensor inputs are not monitored and the CT424 ceases all regular operations. Instead, the unit enters a self-test sequence.

The remaining mode is Peak Display Mode. Peak Display Mode is actually part of Monitoring Mode since sensor inputs are still monitored, but rather than displaying sensor input temperatures, temperature peaks are displayed.

5.1.1 Monitoring Mode

This mode is normally entered automatically upon application of power, provided no severe errors are encountered, and is characterized by the display of a single sensor input temperature or status. For example, if **1 100C** is displayed, this means that the sensor connected to Channel 1 is reading 100 degrees Celsius.

From this mode, the following front panel buttons will perform the functions indicated.

5.1.1.1 PEAK/RESET

Pressing this button will enter the Peak Display Mode. This mode displays the minimum and maximum measured temperatures since the last time peaks were reset.

See [Peak Display Mode](#) section for more information.

5.1.1.2 MANUAL FAN

Pressing this button will toggle the Manual Fan. When Manual Fan is enabled, the LED on the Manual Fan button will illuminate and force the Fan Relay to engage. The FAN LED will also illuminate to indicate the Fan Relay is engaged.

The Manual Fan will remain active until either the MANUAL FAN button is pressed again, or until the Fan Timeout, if enabled, expires.

5.1.1.3 TEST

Pressing and holding the TEST button will cause the CT424 to enter Test Mode.

See the [Test Mode](#) section for more information.

5.1.1.4 SILENCE

Pressing this button will silence the Buzzer until another trip occurs that has been configured to sound the Buzzer, or until the Silence Timeout, if enabled, expires.

5.1.1.5 CANCEL

In Monitor mode, the CANCEL button will cancel all trips for the displayed channel. If the condition(s) that caused the trip(s) still exists, the trip will not cancel.

An alternative way to automatically cancel a trip when the trip condition no longer exists is to use the hysteresis feature.

5.1.1.6 ENTER/MENU

From Monitor Mode, pressing and holding this button will cause the CT424 to enter Setup Mode.

5.1.1.7 UP and DOWN

While in Monitor Mode, these buttons will cycle through the displayed channel if the **FnY** display mode is selected. The displayed channel is indicated on the far left digit. Note that channel **C** is the CJC temperature, and this is the only way to view the CJC temperature.

5.1.2 Peak Display Mode

This mode displays the minimum and maximum measured temperatures since the last time peaks were reset. These values are stored in non-volatile memory and therefore are unaffected by a loss of power.

When in Peak Display Mode, the LED on the PEAK/RESET button will illuminate and initially the minimum temperature for Channel 1 will be displayed. This is indicated by **l _** starting at the left, followed by the temperature value. Pressing the UP button will proceed to the maximum temperature for Channel 1, which is represented by an overscore instead of an underscore. Pressing UP once again will continue to Channel 2 minimum. Pressing the UP button repeatedly will advance through the following sequence, as shown in Figure 11.

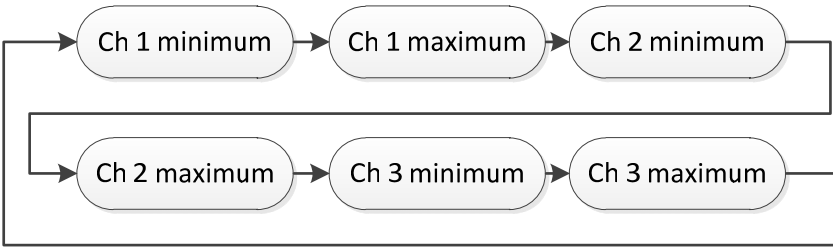

Figure 11

Pressing the DOWN button will move backwards through the same sequence.

Press CANCEL or PEAK/RESET again to exit Peak Display Mode.

Pressing and holding PEAK/RESET while in Monitor Mode or Peak Display Mode until **dOnE** is displayed will clear the peak values; the minimum/maximum temperature values for all channels will be cleared and will be displayed as --- until a valid temperature is read for that channel.

5.1.3 Setup Mode

See [Configuration](#) section.

5.1.4 Test Mode

This mode tests the front panel buttons, displays/LEDs, relay outputs, and 4-20mA loop output. While in this mode, all sensor monitoring and normal output control ceases.

If a password is set, it will be requested before continuing into Test Mode.

In Test Mode the following will occur:

- All front panel displays and LEDs will light
- The rear two MODBUS LEDs will light
- All three relays will energize (NO will be connected to COM)
- The Buzzer will continuously sound
- The 4-20mA loop output will cycle between 4mA, 12mA, and 20mA outputs.
- Pressing a button will display the button number on the display

Press and hold CANCEL to exit from Test Mode. The CT424 will reset (behave as if power was momentarily disconnected) when exiting Test Mode.

Test Mode will automatically exit after two minutes.

5.2 Access Restrictions

The CT424 allows the user to set two passwords that restrict access to configuration settings. A password on the CT424 is a 4 digit number between **0001** and **9999**, while **0000** disables the password. Two passwords are available; Primary Password and Secondary Password. Setting a Primary Password requires users to enter a password before entering Configuration Mode or Test Mode. The Secondary Password, if set, allows a user to view and change temperature setpoints only. See [Table 2](#) for a full description on how the Primary Password and Secondary Password interact.

When a password is required, the user will be prompted for one by displaying **0_ _ _**. Use the UP and DOWN buttons to set the first digit, and then press ENTER/MENU to move to the next digit. Repeat until all digits are set. If the correct password is entered, access will be granted. If the incorrect password is entered, **dEnI Ed** is displayed momentarily before returning to Monitor Mode. If there is no activity for five seconds while entering the password, the CT424 will automatically revert back to Monitor Mode.

Should the user set the Primary Password and the Secondary Password to the same value, the CT424 will behave as if the Secondary Password is disabled, i.e. it will be impossible to access the setpoint-only configuration.

Note that both passwords, like all of the CT424's settings, can be read and changed via MODBUS regardless of whether a password is set or not.

Primary Password set?	Secondary Password set?	Result
No	(cannot set when Primary is disabled)	No password required for any function
Yes	No	Single password required for entering Configuration and Test mode
Yes	Yes	Separate passwords for access to full configuration and Test Mode(Primary), and access to a setpoint only configuration (Secondary)

Table 2

5.3 Special Functions

5.3.1 Recovery

The CT424's configuration may be reset to defaults by pressing and holding the UP and DOWN buttons while applying power. Wait at least two seconds before releasing UP and DOWN. A progress indicator will be displayed while defaults are applied, then **dOnE** will be displayed. This is particularly useful if the Primary Password is forgotten.

WARNING: All user settings are erased and set to defaults when a recovery is performed.

5.3.2 Error Reporting

The CT424 is capable of reporting several errors. Each of these errors is displayed as **Err** followed by a code. The following list describes each possible type of error:

Err S: This is displayed on startup if the settings retrieved from non-volatile memory fail the error check. If this error occurs, this error message will be displayed for 2 seconds followed by **rESEtP**. The CT424 will then wait for the user to either press ENTER/MENU or CANCEL. Pressing ENTER/MENU will clear the settings in non-volatile memory and set everything to factory defaults. Pressing CANCEL will prevent a factory reset, but the CT424 may not operate correctly. The factory default listing is in [7.4.7](#).

Err Lo: This error indicates the respective sensor input channel is reporting a temperature below the allowed range of the CT424. This is often due to the incorrect sensor type selected, or a defective or missing sensor.

Err Hi: This error indicates the respective sensor input channel is reporting a temperature above the allowed range of the CT424. This is often due to the incorrect sensor type selected, or a defective or missing sensor.

Err Cj: This error indicates the CJC sensor is reporting an invalid temperature, and is visible only if the user has chosen to display the CJC temperature. Valid readings are within ten degrees Celsius below the minimum and ten degrees Celsius above the maximum rated ambient temperature of the CT424. This error may be caused by an ambient temperature outside the acceptable range, or a hardware failure.

Should this error condition occur, any inputs configured to use thermocouples will be driven out of range and will report **Err Lo** or **Err Hi**, depending on the nature of the CJC failure.

Err Ad: This error indicates the sensor input circuitry is no longer reporting sensor readings. If this occurs, the CT424 will halt all operations, sound the Buzzer, and engage all outputs while respecting the Reverse Acting Relay settings.

5.3.3 USB Reset

If there is any difficulty using the USB connection, such as errors indicating the USB device is not recognized or difficulty opening the virtual COM port the USB connection provides, the CT424's USB interface may require resetting. To do this, make sure the CT424 is powered

and the USB cable attached between the CT424 and the computer. Momentarily press the TEST button. The button only has to be held long enough for the LED on the TEST button to light. The LED will turn off when the button is released; this indicates the USB reset has occurred.

6 MODBUS

The MODBUS interfaces on the CT424 allow access to all configuration values, sensor readings, stored peak values, relay and Buzzer status, and 4-20mA loop status. The configuration values may be read or written, while the remaining values are read-only. Configuration values are considered to be in Holding Registers, while the read-only status values are considered to be in Input Registers.

If a written value is not within the valid range, the CT424 will automatically change it to the factory default value, which is listed in [7.4.7](#).

A Function Code is a designator in the MODBUS command that specifies the type of command being sent. Three function codes are supported by the CT424: 0x03, 0x04, and 0x10. These are discussed in greater detail in the following sections.

6.1 Holding Registers

The holding registers contain the configuration values. These may be read or written by using function codes 0x03 or 0x10, respectively.

Changes made to any holding register via MODBUS are not automatically saved to non-volatile memory, but rather exist only in RAM. In order to save the configuration to non-volatile memory after a change or multiple changes, the following command must be issued, which is essentially writing the value 0x1234 to the non-existent address of 0x0100:

(MODBUS ID) 0x10 0x01 0x00 0x00 0x01 0x02 0x12 0x34 (2 byte CRC)

If multiple changes are to be made, it's best to write those changes first, and then issue the above command to save everything at once.

Note that if the baud rate/USB setting is changed, it will not take effect until the CT424 is power cycled. Although it's not prevented, it's best to configure the communication settings via the front panel interface.

Another way to write the configuration to non-volatile memory is to enter Configuration Mode then press CANCEL to exit. Leaving Configuration Mode with the CANCEL button writes the configuration settings, regardless of how they were modified, to non-volatile memory.

The format of the command to read values using Function Code 0x03 is as follows:

W	MODBUS ID of the CT424
0x03	Function Code
X	16 bit starting register address, MSB first

Y	Number of 16 bit values to return, MSB first
CRC	2 byte cyclic redundancy check value

Example

Read two values from MODBUS ID 0x01, starting at address 0x0001:

0x01 0x03 0x00 0x01 0x00 0x02 0x95 0xCB

The format of the command to write values is as follows:

w	MODBUS ID of the CT424
0x10	Function Code
x	16 bit starting register address
y	16 bit value representing the number of 16 bit registers to write
z	8 bit value representing the number of 8 bit data values to follow. This value equals (2 * y)
value 1	The first 16 bit value to be written
value n	Additional 16 bit values to be written
CRC	cyclic redundancy check

Example

Write 0x1234 0x5678 starting at address 0x0000:

0x01 0x10 0x00 0x00 0x00 0x02 0x04 0x12 0x34 0x56 0x78 0x88 0x9B

Register Address	Description	Value Format
0x0000	Temperature Scale, Channel Display	A
0x0001	Audible Silence Length, Fan Exerciser Duration	B
0x0002	Fan Exerciser Period, Manual Fan Timeout	C
0x0003	Primary Password	D
0x0004	Secondary Password	D
0x0005	4-20 Loop Power, 4-20 Loop Source	E
0x0006	4-20 Loop Zero Value	F
0x0007	4-20 Loop Span Value	G
0x0008	MODBUS Address, RS-485 Baud Rate/USB Selection	H
0x0009	Reserved	
0x000A	Fan Relay Reverse Acting, Trip Relay Reverse Acting	I
0x000B	Alarm Relay Reverse Acting, Display Brightness	J
0x000C	Channel 1 Sensor Type, Sensor Offset	K
0x000D	1 Trip-A Enable, 1 Trip-A Trip On Failure Enable	I
0x000E	1 Trip-A Setpoint	L
0x000F	1 Trip-A Hysteresis	M
0x0010	1 Trip-A Over/Under, 1 Trip-A Fan Relay Enable	N
0x0011	1 Trip-A Trip Relay Enable, 1 Trip-A Alarm Relay Enable	I
0x0012	1 Trip-A Buzzer Enable, 1 Trip-A Output Reset Method	O
0x0013	1 Trip-B Enable, 1 Trip-B Trip On Failure Enable	I
0x0014	1 Trip-B Setpoint	L
0x0015	1 Trip-B Hysteresis	M
0x0016	1 Trip-B Over/Under, 1 Trip-B Fan Relay Enable	N
0x0017	1 Trip-B Trip Relay Enable, 1 Trip-B Alarm Relay Enable	I
0x0018	1 Trip-B Buzzer Enable, 1 Trip-B Output Reset Method	O
0x0019	1 Trip-C Enable, 1 Trip-C Trip On Failure Enable	I
0x001A	1 Trip-C Setpoint	L
0x001B	1 Trip-C Hysteresis	M
0x001C	1 Trip-C Over/Under, 1 Trip-C Fan Relay Enable	N
0x001D	1 Trip-C Trip Relay Enable, 1 Trip-C Alarm Relay Enable	I
0x001E	1 Trip-C Buzzer Enable, 1 Trip-C Output Reset Method	O
0x001F	Channel 2 Sensor Type, Sensor Offset	K
0x0020	2 Trip-A Enable, 2 Trip-A Trip On Failure Enable	I
0x0021	2 Trip-A Setpoint	L
0x0022	2 Trip-A Hysteresis	M
0x0023	2 Trip-A Over/Under, 2 Trip-A Fan Relay Enable	N
0x0024	2 Trip-A Trip Relay Enable, 2 Trip-A Alarm Relay Enable	I
0x0025	2 Trip-A Buzzer Enable, 2 Trip-A Output Reset Method	O

0x0026	2 Trip-B Enable, 2 Trip-B Trip On Failure Enable	I
0x0027	2 Trip-B Setpoint	L
0x0028	2 Trip-B Hysteresis	M
0x0029	2 Trip-B Over/Under, 2 Trip-B Fan Relay Enable	N
0x002A	2 Trip-B Trip Relay Enable, 2 Trip-B Alarm Relay Enable	I
0x002B	2 Trip-B Buzzer Enable, 2 Trip-B Output Reset Method	O
0x002C	2 Trip-C Enable, 2 Trip-C Enable Trip On Failure Enable	I
0x002D	2 Trip-C Enable Setpoint	L
0x002E	2 Trip-C Enable Hysteresis	M
0x002F	2 Trip-C Enable Over/Under, 2 Trip-C Enable Fan Relay Enable	N
0x0030	2 Trip-C Enable Trip Relay Enable, 2 Trip-C Enable Alarm Relay Enable	I
0x0031	2 Trip-C Enable Buzzer Enable, 2 Trip-C Enable Output Reset Method	O
0x0032	Channel 3 Sensor Type, Sensor Offset	K
0x0033	3 Trip-A Enable, 3 Trip-A Trip On Failure Enable	I
0x0034	3 Trip-A Setpoint	L
0x0035	3 Trip-A Hysteresis	M
0x0036	3 Trip-A Over/Under, 3 Trip-A Fan Relay Enable	N
0x0037	3 Trip-A Trip Relay Enable, 3 Trip-A Alarm Relay Enable	I
0x0038	3 Trip-A Buzzer Enable, 3 Trip-A Output Reset Method	O
0x0039	3 Trip-B Enable, 3 Trip-B Trip On Failure Enable	I
0x003A	3 Trip-B Setpoint	L
0x003B	3 Trip-B Hysteresis	M
0x003C	3 Trip-B Over/Under, 3 Trip-B Fan Relay Enable	N
0x003D	3 Trip-B Trip Relay Enable, 3 Trip-B Alarm Relay Enable	I
0x003E	3 Trip-B Buzzer Enable, 3 Trip-B Output Reset Method	O
0x003F	3 Trip-C Enable, 3 Trip-C Trip On Failure Enable	I
0x0040	3 Trip-C Setpoint	L
0x0041	3 Trip-C Hysteresis	M
0x0042	3 Trip-C Over/Under, 3 Trip-C Fan Relay Enable	N
0x0043	3 Trip-C Trip Relay Enable, 3 Trip-C Alarm Relay Enable	I
0x0044	3 Trip-C Buzzer Enable, 3 Trip-C Output Reset Method	O

Table 3

6.2 Input Registers

The Input Registers contain read-only values such as sensor input values and peak values. These are read-only by using Function Code 0x04.

The format of the command to read values using Function Code 0x03 is as follows:

W	MODBUS ID of the CT424
0x04	Function Code
X	16 bit starting register address, MSB first
Y	number of 16 bit values to return, MSB first
CRC	cyclic redundancy check

Example

Read two values from MODBUS ID 0x01, starting at address 0x0001:

0x01 0x04 0x00 0x01 0x00 0x02 0x20 0x0B

Register Address	Description	Value Format
0x0000	Cold Junction Compensation Temperature	P
0x0001	Channel 1 Temperature	P
0x0002	Channel 2 Temperature	P
0x0003	Channel 3 Temperature	P
0x0004	4-20 Loop Output	Q
0x0005	Relay Status	R
0x0006	Channel 1 Minimum	P
0x0007	Channel 1 Maximum	P
0x0008	Channel 2 Minimum	P
0x0009	Channel 2 Maximum	P
0x000A	Channel 3 Minimum	P
0x000B	Channel 3 Maximum	P

Table 4

6.3 Value Format Key

Table 5 contains the legend for the last column of the MODBUS register tables.

Value Format	Definition																
A	<p>This register holds two enumerated settings. The upper byte holds the temperature scale, and lower byte holds the channel display mode.</p> <p>Temperature scale:</p> <table border="1"><thead><tr><th>Value</th><th>Mode</th></tr></thead><tbody><tr><td>0x00</td><td>Fahrenheit</td></tr><tr><td>0x01</td><td>Celsius</td></tr></tbody></table> <p>Channel Display Mode:</p> <table border="1"><thead><tr><th>Value</th><th>Mode</th></tr></thead><tbody><tr><td>0x00</td><td>High channel</td></tr><tr><td>0x01</td><td>Low channel</td></tr><tr><td>0x02</td><td>Any channel</td></tr><tr><td>0x03</td><td>Cycle channel</td></tr></tbody></table> <p>Example Set scale to Celsius and display mode to Any: 0x0102</p>	Value	Mode	0x00	Fahrenheit	0x01	Celsius	Value	Mode	0x00	High channel	0x01	Low channel	0x02	Any channel	0x03	Cycle channel
Value	Mode																
0x00	Fahrenheit																
0x01	Celsius																
Value	Mode																
0x00	High channel																
0x01	Low channel																
0x02	Any channel																
0x03	Cycle channel																

B	<p>This register holds two integer values. The upper byte holds the silence duration, and the lower byte holds the fan exerciser duration.</p> <p>Silence: Valid values are 0 – 120, representing the number of minutes the Buzzer is silenced. 0 disables feature.</p> <p>Fan Exerciser Duration: Valid values are 1 – 120, representing the number of minutes the fan relay is engaged when Fan Exerciser is active.</p> <p>Example Set Silence to 60 (0x3C) and Duration to 5 (0x05): 0x3C05</p>
C	<p>This register holds two integer values. The upper byte holds the Fan Exerciser Period, and the lower byte holds the Manual Fan Timeout.</p> <p>Fan Exerciser Period: Valid values are 0 – 60, representing the number of days between Fan Exerciser activations. 0 disables Fan Exerciser.</p> <p>Manual Fan Timeout: Valid values are 0 – 120, representing the number of minutes that elapses before a Manual Fan activation is disengaged. 0 disables feature.</p> <p>Example Set Period to 10 (0x0A) and Timeout to disabled (0x00): 0x0A00</p>
D	<p>This register holds one of the passwords.</p> <p>Valid values are 0 – 9999. 0 disables the password. The LSB is first.</p> <p>Example Set password to 1234 (0x04D2): 0xD204</p>

E	<p>This register holds two integer values. The upper byte holds the 4-20 Loop Power Mode, and the lower byte holds the 4-20 Loop Source.</p> <p>4-20 Loop Power Mode:</p> <table border="1" data-bbox="467 239 834 352"> <thead> <tr> <th>Value</th> <th>Mode</th> </tr> </thead> <tbody> <tr> <td>0x00</td> <td>Loop</td> </tr> <tr> <td>0x01</td> <td>Internal</td> </tr> </tbody> </table> <p>4-20 Loop Source:</p> <table border="1" data-bbox="467 424 834 642"> <thead> <tr> <th>Value</th> <th>Mode</th> </tr> </thead> <tbody> <tr> <td>0x00</td> <td>High channel</td> </tr> <tr> <td>0x01</td> <td>Low channel</td> </tr> <tr> <td>0x02</td> <td>Channel 1</td> </tr> <tr> <td>0x03</td> <td>Channel 2</td> </tr> <tr> <td>0x04</td> <td>Channel 3</td> </tr> </tbody> </table> <p>Example Set Power Mode to Internal (0x01) and Source to Channel 2 (0x03): 0x0103</p>	Value	Mode	0x00	Loop	0x01	Internal	Value	Mode	0x00	High channel	0x01	Low channel	0x02	Channel 1	0x03	Channel 2	0x04	Channel 3
Value	Mode																		
0x00	Loop																		
0x01	Internal																		
Value	Mode																		
0x00	High channel																		
0x01	Low channel																		
0x02	Channel 1																		
0x03	Channel 2																		
0x04	Channel 3																		
F	<p>This register holds the 4-20 Loop Zero value.</p> <p>Valid values are -50C to 250C, or -58F to 482F. The appropriate range must be observed depending on what temperature scale the unit is set to. The LSB is first.</p> <p>Example Set to -20C (0xFFEC): 0xECFF, and Temperature Scale must be set to Celsius.</p>																		
G	<p>This register holds the 4-20 Loop Span value.</p> <p>Valid values are 50C to 350C, or 122F to 662F, although this range changes based on the 4-20 Loop Zero Value. The appropriate range must be observed depending on what temperature scale the unit is set to. The LSB is first.</p> <p>Example Set to 200F (0xC8): 0xC800, and Temperature Scale must be set to Fahrenheit.</p>																		

H	<p>This register holds two integer values. The upper byte holds the MODBUS Address, and the lower byte holds the RS-485 Baud Rate/USB Selection.</p> <p>MODBUS Address: Valid values are 1 to 247.</p> <p>RS485 Baud Rate/USB Selection:</p> <table border="1" data-bbox="467 346 836 682"> <thead> <tr> <th>Value</th> <th>Baud Rate</th> </tr> </thead> <tbody> <tr> <td>0x00</td> <td>300</td> </tr> <tr> <td>0x01</td> <td>1200</td> </tr> <tr> <td>0x02</td> <td>2400</td> </tr> <tr> <td>0x03</td> <td>4800</td> </tr> <tr> <td>0x04</td> <td>9600</td> </tr> <tr> <td>0x05</td> <td>19200</td> </tr> <tr> <td>0x06</td> <td>38400</td> </tr> <tr> <td>0x07</td> <td>USB</td> </tr> </tbody> </table> <p>NOTE: Modifying the RS485 Baud Rate/USB Selection value via MODBUS will result in the change not being applied until the unit is restarted/power-cycled.</p> <p>Example Set MODBUS address to 16 (0x10) and use RS-485 interface at 9600 (0x04) 0x1004</p>	Value	Baud Rate	0x00	300	0x01	1200	0x02	2400	0x03	4800	0x04	9600	0x05	19200	0x06	38400	0x07	USB
Value	Baud Rate																		
0x00	300																		
0x01	1200																		
0x02	2400																		
0x03	4800																		
0x04	9600																		
0x05	19200																		
0x06	38400																		
0x07	USB																		
I	<p>This register holds two Enable/Disable settings. The first setting listed in the Register Map for this value format applies to the upper byte, and the second setting applies to the lower byte.</p> <p>Upper byte:</p> <table border="1" data-bbox="467 1144 836 1255"> <thead> <tr> <th>Value</th> <th>Mode</th> </tr> </thead> <tbody> <tr> <td>0x00</td> <td>Disabled</td> </tr> <tr> <td>0x01</td> <td>Enabled</td> </tr> </tbody> </table> <p>Lower byte:</p> <table border="1" data-bbox="467 1327 836 1438"> <thead> <tr> <th>Value</th> <th>Mode</th> </tr> </thead> <tbody> <tr> <td>0x00</td> <td>Disabled</td> </tr> <tr> <td>0x01</td> <td>Enabled</td> </tr> </tbody> </table> <p>Example Enable the first setting(0x01) and disable second setting(0x00): 0x0100</p>	Value	Mode	0x00	Disabled	0x01	Enabled	Value	Mode	0x00	Disabled	0x01	Enabled						
Value	Mode																		
0x00	Disabled																		
0x01	Enabled																		
Value	Mode																		
0x00	Disabled																		
0x01	Enabled																		

J	<p>This register holds two integer values. The upper byte holds the Alarm Relay Reverse Acting setting, and the lower byte holds the Display Brightness setting.</p> <p>Alarm Relay Reverse Acting:</p> <table border="1" data-bbox="467 239 834 352"> <thead> <tr> <th>Value</th> <th>Mode</th> </tr> </thead> <tbody> <tr> <td>0x00</td> <td>Disabled</td> </tr> <tr> <td>0x01</td> <td>Enabled</td> </tr> </tbody> </table> <p>Display Brightness:</p> <table border="1" data-bbox="467 424 834 571"> <thead> <tr> <th>Value</th> <th>Brightness</th> </tr> </thead> <tbody> <tr> <td>0x00</td> <td>Low</td> </tr> <tr> <td>0x01</td> <td>Medium</td> </tr> <tr> <td>0x02</td> <td>High</td> </tr> </tbody> </table> <p>Example Enable Alarm Relay Reverse Acting (0x01) and set brightness to Medium(0x01): 0x0101</p>	Value	Mode	0x00	Disabled	0x01	Enabled	Value	Brightness	0x00	Low	0x01	Medium	0x02	High
Value	Mode														
0x00	Disabled														
0x01	Enabled														
Value	Brightness														
0x00	Low														
0x01	Medium														
0x02	High														
K	<p>This register holds the sensor type and sensor offset setting for the respective channel. The LSB is first.</p> <table border="1" data-bbox="467 856 941 1079"> <thead> <tr> <th>Value</th> <th>Type</th> </tr> </thead> <tbody> <tr> <td>0x00</td> <td>Off</td> </tr> <tr> <td>0x01</td> <td>Platinum RTD 100Ω</td> </tr> <tr> <td>0x02</td> <td>Platinum RTD 1000Ω</td> </tr> <tr> <td>0x03</td> <td>Type K Thermocouple</td> </tr> <tr> <td>0x04</td> <td>Type E Thermocouple</td> </tr> </tbody> </table> <p>Sensor offset: Valid values are -100 to 100.</p> <p>Example 1 Set the sensor type to Platinum RTD 100Ω and offset to -2: 0x01FE</p> <p>Example 2 Set the sensor type to Type K Thermocouple and offset to 10 (0x0A): 0x030A</p>	Value	Type	0x00	Off	0x01	Platinum RTD 100Ω	0x02	Platinum RTD 1000Ω	0x03	Type K Thermocouple	0x04	Type E Thermocouple		
Value	Type														
0x00	Off														
0x01	Platinum RTD 100Ω														
0x02	Platinum RTD 1000Ω														
0x03	Type K Thermocouple														
0x04	Type E Thermocouple														
L	<p>This register holds a Trip Setpoint.</p> <p>Valid values are -50C to 300C, or -58F to 572F. The appropriate range must be observed depending on what temperature scale the unit is set to. The LSB is first.</p> <p>Example Set to 200F (0xC8): 0xC800, and Temperature Scale must be set to Fahrenheit.</p>														

M	<p>This register holds a Trip Hysteresis.</p> <p>Valid values are 1C to 50C, or 1F to 122F. The appropriate range must be observed depending on what temperature scale the unit is set to. The LSB is first.</p> <p>Example Set to 200F (0xC8): 0xC800, and Temperature Scale must be set to Fahrenheit.</p>												
N	<p>This register holds two integer values. The upper byte holds the Trip Over/Under setting, and the lower byte holds the Fan Relay Enable setting.</p> <p>Trip Over/Under:</p> <table border="1" data-bbox="467 562 834 674"> <thead> <tr> <th>Value</th> <th>Mode</th> </tr> </thead> <tbody> <tr> <td>0x00</td> <td>Over</td> </tr> <tr> <td>0x01</td> <td>Under</td> </tr> </tbody> </table> <p>Fan Relay Enable:</p> <table border="1" data-bbox="467 743 834 854"> <thead> <tr> <th>Value</th> <th>Mode</th> </tr> </thead> <tbody> <tr> <td>0x00</td> <td>Disabled</td> </tr> <tr> <td>0x01</td> <td>Enabled</td> </tr> </tbody> </table> <p>Example Set to Trip Under (0x01) and disable Fan Relay Enable (0x00): 0x0100</p>	Value	Mode	0x00	Over	0x01	Under	Value	Mode	0x00	Disabled	0x01	Enabled
Value	Mode												
0x00	Over												
0x01	Under												
Value	Mode												
0x00	Disabled												
0x01	Enabled												
0	<p>This register holds two integer values. The upper byte holds the Buzzer Enable setting, and the lower byte holds the Output Reset Method setting.</p> <p>Buzzer Enable:</p> <table border="1" data-bbox="467 1178 834 1289"> <thead> <tr> <th>Value</th> <th>Mode</th> </tr> </thead> <tbody> <tr> <td>0x00</td> <td>Disabled</td> </tr> <tr> <td>0x01</td> <td>Enabled</td> </tr> </tbody> </table> <p>Output Reset Method:</p> <table border="1" data-bbox="467 1358 1002 1470"> <thead> <tr> <th>Value</th> <th>Mode</th> </tr> </thead> <tbody> <tr> <td>0x00</td> <td>Reset Using Hysteresis</td> </tr> <tr> <td>0x01</td> <td>Reset Using Cancel</td> </tr> </tbody> </table> <p>Example Disable Buzzer Enable (0x01) and set Reset Method to Using Hysteresis (0x0): 0x0100</p>	Value	Mode	0x00	Disabled	0x01	Enabled	Value	Mode	0x00	Reset Using Hysteresis	0x01	Reset Using Cancel
Value	Mode												
0x00	Disabled												
0x01	Enabled												
Value	Mode												
0x00	Reset Using Hysteresis												
0x01	Reset Using Cancel												

P	<p>This register holds a temperature value, and is read-only.</p> <p>Valid values are -50C to 300C, or -58F to 572F. If reading the CJC, the range is considerably less due to the ambient temperature rating of the unit not extending as far as the sensor input range. A value of 10,000 or -10,000 indicates the sensor input is too high or too low, respectively.</p> <p>If reading a minimum or maximum value, 10,000 or -10,000 will be read if a valid temperature value has not yet been written. The LSB is first.</p> <p>Example 1 0x4D00: Read as 0x004D, or 77.</p> <p>Example 2 0xD9FF: Read as 0xFFD9, or -39.</p>
Q	<p>This register holds the value used to control the 4-20mA loop, and is read-only.</p> <p>Valid values are 0 – 3900. A value of 0 represents the minimum possible 3.5mA output, and then 200 counts represent each additional mA. Therefore, a value of 3900 represents a 23mA output. The LSB is first.</p> <p>The current loop output can be calculated by the following equation: $I = 3.5 + (x / 200)$ Where: I = current loop output in mA x = 4-20mA loop value</p> <p>Example 0x2403 Read as 0x0324, or 804 $I = 3.5 + (804 / 200) = 7.52\text{mA}$</p>

R	<p>This register holds a bit-mapped value that indicates relay status, and is read-only.</p> <p>Valid values are 0 – 15. The three least significant bits indicate if a specific relay is engaged or disengaged. If a bit is set, the relay is engaged; that is, the NO contacts are connected to Common. The fourth bit indicates if the Buzzer is on. The LSB is first. The mapping is show below.</p> <table border="1" style="margin-left: auto; margin-right: auto;"> <thead> <tr> <th>Value</th> <th>Relay</th> </tr> </thead> <tbody> <tr> <td>0x0001</td> <td>Fan</td> </tr> <tr> <td>0x0002</td> <td>Alarm</td> </tr> <tr> <td>0x0004</td> <td>Trip</td> </tr> <tr> <td>0x0008</td> <td>Buzzer</td> </tr> </tbody> </table> <p>Example 0x0300 Read as 0x0003, or 3 Hence, the Fan and Alarm relays are engaged.</p>	Value	Relay	0x0001	Fan	0x0002	Alarm	0x0004	Trip	0x0008	Buzzer
Value	Relay										
0x0001	Fan										
0x0002	Alarm										
0x0004	Trip										
0x0008	Buzzer										

Table 5

7 Specifications

7.1 Inputs

7.1.1 Power

Option A: 120 to 240 VAC 50/60Hz, 120 to 240 VDC, 17W maximum

Option B: 21 to 36 VDC, 8W maximum

Fuses shall be replaced with 250V, 500mA GMA (5x20mm fast acting) type.

7.1.2 Sensors

1, 2 or 3 RTDs or Thermocouples in any combination

Fully electrically isolated (collectively)

RTD:

PD/PE (100Ω @ 0°C, 0.00385Ω/Ω/°C)

PF (1000Ω @ 0°C, 0.00385Ω/Ω/°C)

Thermocouple:

Type E

Type K

7.2 Outputs

7.2.1 4-20mA loop

Fully electrically isolated in **LOOP** mode only

Output range: 3.8mA to 21mA

Sensor under-range: 3.5mA

Sensor over-range: 23mA

Loop supply voltage (**LOOP** mode): 7.5VDC to 36VDC

Internal loop supply voltage (**INT** mode): 12VDC

Minimum loop resistance: Zero ohms

Maximum loop resistance: $R_{loopmax} = (V_{supply} - 7.5) / 0.023$

7.2.2 Relays

Fan:

240VAC, SPST, 22A, 1 ½ HP, General Use in 72°C ambient. 28VDC, SPST, 20A.

240VAC, SPST, 30A, 1 ½ HP, General Use in 55°C ambient. 28VDC, SPST, 20A.

Alarm and Trip:

240VAC, SPDT, 10A, General Use. 28 VDC, 10A.

7.3 Communication

7.3.1 RS-485

Fully electrically isolated
RTU mode
300 to 38,400 bps
8 data bits, no parity

7.3.2 USB

USB 2.0, virtual COM port

7.4 General

7.4.1 Accuracy

+/-2°C (3°F) in -30 to 72°C ambient, over entire input range

7.4.2 Dimensions

9.90"L x 6.30"W x 1.8"D

7.4.3 Weight

3.2 lbs

7.4.4 Environmental

Operating temperature: -30 to 72°C @ 90% relative humidity, non-condensing
Storage temperature: -40 to 85°C @ 90% relative humidity, non-condensing

7.4.5 Construction

Full steel construction

7.4.6 Approvals

UL/cUL Recognition – File E211718
CE Certified (CT424A only; CT424B designed to CE standards)

7.4.7 Factory Defaults

Parameter	Default Setting
Inputs	Pt100
Offsets	0
Scale	Celsius
CHdISP	Any
4-20, Power	Loop
4-20, Source	HI
4-20, Zero	-50
4-20, Span	350
Silent	Disabled
Trip, Setting	Disabled
Trip, Error	Disabled
Trip, Fan	Disabled
Trip, Alarm	Disabled
Trip, Trip	Disabled
Trip, Buzzer	Disabled

Trip, Setpoint	100
Trip, Direction	Over
Trip, Trip Reset	Reset using Hysteresis
Trip, Hysteresis	10
Serial, ID	1
Serial, Bitrate	USB
Fan Exerciser, Period	Disabled
Fan Exerciser, Duration	10
Fan Timeout	60
Reverse Acting Relays, Fan	Disabled
Reverse Acting Relays, Trip	Disabled
Reverse Acting Relays, Alarm	Disabled
Brightness	Maximum
Password, Primary	Disabled
Password, Secondary	Disabled

8 Glossary

Byte	A group of eight bits that can represent 256 unique values.
CJC	Cold Junction Compensation: Adds the temperature of a thermocouple's instrumentation end to determine the thermocouple's junction temperature.
EMI	ElectroMagnetic Interference: A disturbance in an electrical circuit caused by electrical or magnetic fields from another source.
ESD	ElectroStatic Discharge: A sudden flow of electricity between two objects caused by buildup of static electricity.
LSB	Least Significant Byte: The byte in a multi-byte value that represents the lowest value.
MODBUS	A communications protocol frequently used by industrial electronics.
RS-485	A differential serial communications bus frequently used in industrial environments.
RTU	Remote Terminal Unit: A MODBUS communication mode.

9 Change Log

Revision	What Changed
Initial	N/A
1	<u>3.2.2</u> : Reference error Figure 3: Reverse acting relays bubble corrected <u>4.2.7</u> : Reference error <u>7.1.1</u> : Minimum supply voltage increased