

SINEAX B812

Transmitter – Power Supply Unit

for intelligent and conventional 2-wire transmitters,
in housing P12/17 for rail mounting

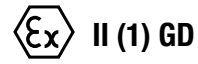

Application

The transmitter-power supply unit **SINEAX B 812** (Fig. 1) provides the DC power supply for **2-wire transmitters** and transfers the measured variable unchanged to the **electrically insulated** output.

All versions of the SINEAX B 812 are **designed for FSK¹ communication**. They are used in conjunction with “intelligent” 2-wire transmitters which are capable of dialogue and operation according to the FSK principle and the HART or user-specific protocol.

The series also includes “intrinsically safe” versions [Ex ia] IIC with an intrinsically safe input. These operate in conjunction with intrinsically safe 2-wire transmitters located in explosion hazard areas.

Provision is made for monitoring the measurement/supply to detect short and open-circuits. Either of these faults is signalled by the red LED.

The instrument fulfils all the important requirements and regulations concerning electromagnetic compatibility **EMV** and **Safety** (IEC 1010 resp. EN 61 010). It was developed and is manufactured and tested in strict accordance with the **quality assurance standard** ISO 9001.

Production QA is also certified according to guideline 94/9/EG.

Features / Benefits

- Designed for FSK communication / This facilitates operation in conjunction with an “intelligent” 2-wire transmitter designed for FSK and with a HART or user-specific protocol
- Electrically insulated between input, output and power supply / Fulfils IEC 1010 resp. EN 61 010
- AC/DC power supply / Universal
- “Intrinsically safe” version [Ex ia] IIC available (see section “Explosion protection data”)
- Measurement/supply circuit monitored for open and short-circuits / Faults signalled by red LED
- Green power on LED
- Compact and narrow

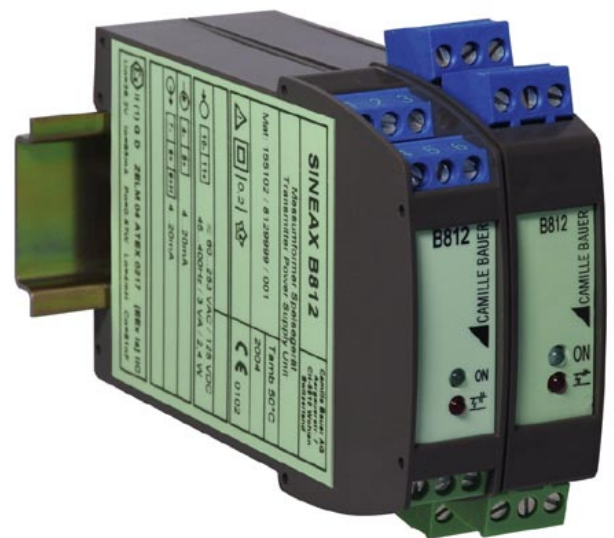

Technical Data

Input \ominus

Measurement / supply circuit

Signal range	4 ... 20 mA
Power supply voltage (I = 20 mA)	18.0 V \pm 1 V
No-load voltage (I = 0 mA)	25.5 V \pm 1 V
Short circuit current limitation	25 mA \pm 2 mA
Source resistance	330 Ω \pm 5 Ω
Open circuit detection	3.5 mA \pm 0.1 mA
Short circuit detection	21.2 mA \pm 0.2 mA

Output \ominus

Signal range	4 ... 20 mA
No-load voltage (I = 0 mA)	17.0 V \pm 1 V
Internal communication resistor R _C	250 Ω
Permitted load	0 ... 750 Ω 0 ... 500 Ω (via R _C)

¹FSK = **F**requency **S**hift **K**eying

SINEAX B812

Transmitter – Power Supply Unit

Power supply →○

Universal power supply for DC and AC

	Low-range version	High-range version
Voltage range AC/DC (absolute limits)	20 – 70 V	60 – 265 V *)
Switching-on current I / τ	2.5 A / 1.0 ms at 24 V DC	20 A / 0.15 ms at 325 V DC
Frequency range AC	45 ... 400 Hz	
Power consumption max.	3 VA / 2.4 W	

*) Voltages > 125 V DC require external protection with max. 10 A trip current. For the Ex version, the data in the EC type examination certificate are valid (U_m = 253 V AC or 125 V DC).

Accuracy

Reference conditions	T _{amb} = 23 °C, I _{load} = 300 Ω Warm up time 20 minutes Power supply = 24 V DC or 230 V AC Range = 16 mA ± 100%
Error tolerance incl. linearity error under reference conditions	± 0.2%
Effect of output load	< 0.1%
Temperature effect	< 0.1% / 10 K
Effect of power supply	< 0.05%

Transfer

Signal current over-range	10%
Response time	< 0.3 ms
HART®	Transparent for HART signals in both directions

Galvanic isolation

All three circuits (input / power supply / output) are galvanically isolated from each other.

Regulations

Electromagnetic compatibility:	EN 50 081-2 EN 50 082-2
Intrinsic safety:	EN 50 020
Protection:	IEC 529 resp. EN 60 529 Terminals IP 20 Housing IP 40
Electrical safety:	IEC 1010 resp. EN 61 010
Working voltage:	< 300 V
Contamination level:	2
Overvoltage category:	III
Test voltage:	3.6 kV
Flammability class	UL 94 V0

Ambient conditions

Operating temperature	-20 ... +50 °C
Storage temperature	-20 ... +70 °C
Relative humidity average	≤ 75%

Installation data

Mounting:	For snapping onto top hat rail (35 x 15 mm or 35 x 7.5 mm) acc. to EN 50 022
Position of use:	Any
Terminal cross section:	0.14 mm ² to 2.5 mm ²
Plug-in terminals:	Coded to prevent incorrect connection
Weight:	Approx. 100 g

Versions

Device Ex-versions [Ex ia] IIC

Power supply	Connection terminals	Order number
60 – 253 V AC / 125 V DC	not plugable	155 102
60 – 253 V AC / 125 V DC	plugable	155 144
20 – 70 V AC / DC	not plugable	155 095
20 – 70 V AC / DC	plugable	155 136

Device standard versions

Power supply	Connection terminals	Order number
60 – 265 V AC / DC	not plugable	155 087
60 – 265 V AC / DC	plugable	155 128
20 – 70 V AC / DC	not plugable	155 079
20 – 70 V AC / DC	plugable	155 110

Explosion protection data

Type examination certificate:	ZELM 04 ATEX 0217
Type of protection:	[Ex ia] IIC
Marking:	EX II (1) GD

U _o	28.2 V
I _o	95 mA
P _o	670 mW
Characteristic	linear

	IIC	IIB
C _o	81 nF	641 nF
L _o	4 mH	15 mH

SINEAX B812 Transmitter – Power Supply Unit

Indicator LEDs

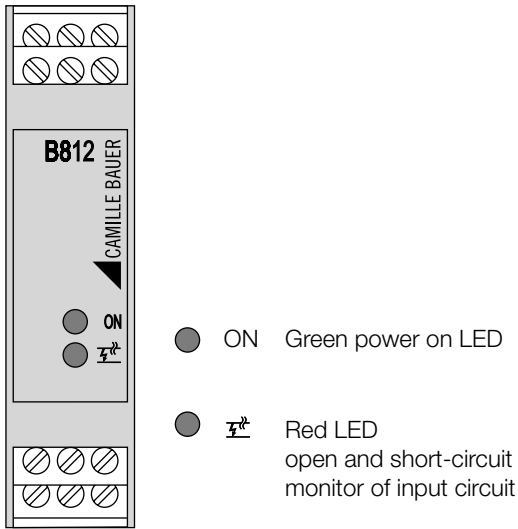

Fig. 2

Electrical connections

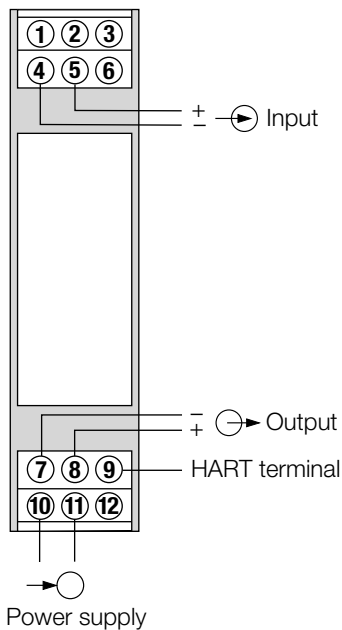

Fig. 3

Dimensional drawings

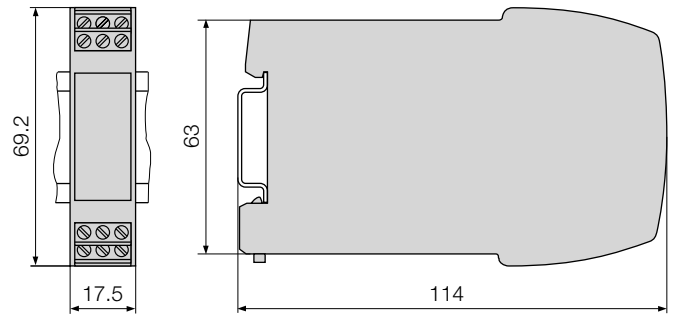

Fig. 4. SINEAX B812 in housing **P12/17** clipped onto a top-hat rail (35 x 15 mm or 35 x 7.5 mm, acc. to EN 50 022). **Connection terminals not plugable.**

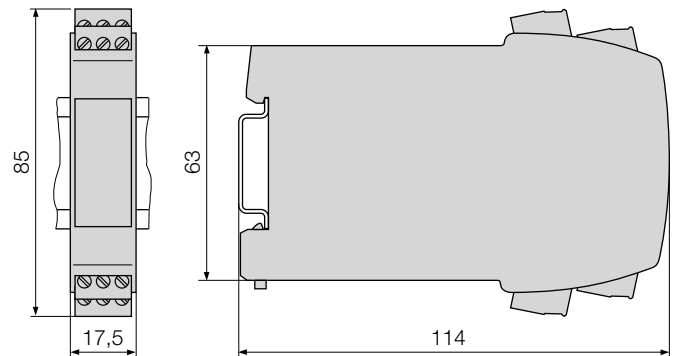

Fig. 5. SINEAX B812 in housing **P12/17 St** clipped onto a top-hat rail (35 x 15 mm or 35 x 7.5 mm, acc. to EN 50 022). **Connection terminals plugable.**

MOD-TRONIC
INSTRUMENTS LIMITED

1 Delta Park Blvd, #12 Brampton, ON L6T 5G1
Tel 905-457-6322 or 1-800-794-5883
Fax 905-457-4716 or 1-800-830-7122
sales@mod-tronic.com www.mod-tronic.com