

11. Versions

Device Ex-versions [EEx ia] IIC

Power supply	Connection terminals	Order number
60 – 253 V AC / 125 V DC	not plugable	155 102
60 – 253 V AC / 125 V DC	plugable	155 144
20 – 70 V AC/DC	not plugable	155 095
20 – 70 V AC/DC	plugable	155 136

Device standard versions

Power supply	Connection terminals	Order number
60 – 265 V AC/DC	not plugable	155 087
60 – 265 V AC/DC	plugable	155 128
20 – 70 V AC/DC	not plugable	155 079
20 – 70 V AC/DC	plugable	155 110

12. Maintenance

The device is maintenance free. Recalibration of the measured signal is not possible.

13. Declaration of conformity

EG - KONFORMITÄTSERKLÄRUNG
DECLARATION OF CONFORMITY

Dokument-Nr. / Document No.: B812.DOC

Hersteller / Manufacturer: Camille Bauer AG
Switzerland

Anschrift / Address: Aargauerstrasse 7
CH-5610 Wohlen

Produktbezeichnung / Product name: Messumformer Speisegerät
Transmitter Power Supply Unit

Typ / Type: SINEAX B812

Das bezeichnete Produkt stimmt mit den Vorschriften folgender Europäischer Richtlinien überein, nachgewiesen durch die Einhaltung folgender Normen:

The above mentioned product has been manufactured according to the regulations of the following European directives proven through compliance with the following standards:

Nr. / No.	Richtlinie / Directive	Messverfahren / Measurement methods
89/336/EWG 89/336/EEC	Elektromagnetische Verträglichkeit - EMV - Richtlinie Electromagnetic compatibility -EMC directive	
EMV / EMC	Fachgrundnorm / Generic Standard	
Störaussendung / Emission	EN 61000-6-4 : 2002	EN 55011 : 1998+A1:1999
Störfestigkeit / Immunity	EN 61000-6-2 : 2002	IEC 61000-4-2 : 1995+A1:1998+A2:2001 IEC 61000-4-3 : 1996+A1:1998+A2:2001 IEC 61000-4-4 : 1995+A1:2001 IEC 61000-4-5 : 1995+A1:2001 IEC 61000-4-6 : 1996+A1:2001 IEC 61000-4-11:1994+A1:2001
73/23/EWG 73/23/EEC	Elektrische Betriebsmittel zur Verwendung innerhalb bestimmter Spannungsgrenzen - Niederspannungsrichtlinie - CE-Kennzeichnung : 95 Electrical equipment for use within certain voltage limits - Low Voltage Directive - Attachment of CE mark : 95	
EN/Norm/Standard	IEC/Norm/Standard	
EN 61 010-1 : 2002	IEC 1010-1 : 2001	

Die explosionsgeschützte Ausführung dieses Produkts stimmt mit der europäischen Richtlinie 94/9/EG überein.

The explosion protected variant of this product has been manufactured according the european directive 94/9.

Ort, Datum / Place, date: Wohlen, den 30. Juni 2004

Unterschrift / Signature: *M. Ulrich* Leiter Technik

Diese Erklärung bescheinigt die Übereinstimmung mit den genannten Richtlinien, beinhaltet jedoch keine Zusicherung von Eigenschaften. Die Sicherheitsanweisungen der mitgelieferten Produktdokumentationen sind zu beachten.
This declaration certifies compliance with the above mentioned directives but does not include a property assurance. The safety notes given in the product documentations, which are part of the supply, must be observed.

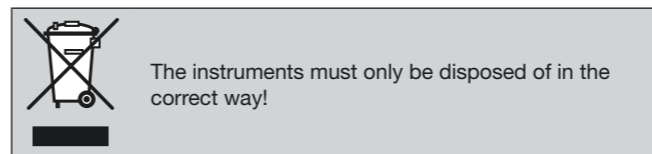

Contents

1. Safety instructions.....	1
1.1 Symbols.....	1
1.2 Proper use.....	1
1.3 Qualifications of the personnel.....	1
1.4 Repairs and modifications.....	1
2. Short description.....	1
3. Indicator LEDs.....	1
4. Installation instructions.....	2
5. Mounting the device.....	2
6. Removal of the device.....	2
7. Dimension drawings.....	2
8. Electrical connections.....	2
8.1 Connection without HART® terminal.....	2
8.2 Connection with HART® terminal.....	2
9. Commissioning.....	3
10. Technical data.....	3
10.1 Input.....	3
10.2 Intrinsically safe input (Ex version).....	3
10.3 Output.....	3
10.4 Accuracy.....	3
10.5 Power supply.....	3
10.6 Transfer.....	3
10.7 Galvanic isolation.....	3
10.8 Ambient conditions.....	3
10.9 Various.....	3
11. Versions.....	4
12. Maintenance.....	4
13. Declaration of conformity.....	4

- The manufacturer is not liable for damage that is caused by improper handling, modifications, or improper use.
- Optional with intrinsically safe input (blue terminals). This is an “associated apparatus” and must not be installed in explosion hazardous areas. The output is not intrinsically safe.

1.3 Qualifications of the personnel

Mounting, installation, and commissioning must only be carried out by properly trained and authorized personnel, who have read and understood these operating instructions.

1.4 Repairs and modifications

Repairs and modifications must only be carried out at our factory. The housing must not be opened. There are no configuration or adjusting elements inside the housing.

We reserve the right to make changes to improve the product.

2. Short description

The device supplies the passive 2-wire transducer (4...20 mA) which is connected to the input with a DC voltage, and transmits the signal current galvanically isolated 1:1 to the output. The current in the output circuit is also supplied by the device. Therefore a passive signal receiver (4...20 mA) must be connected.

The device is transparent for HART® signals in both directions. The 250 Ω resistor integrated in the output circuit permits communication with SMART transmitters.

Open circuit and short circuit in the input circuit are indicated locally by a red LED.

The device is single channel execution and is suitable for mounting on a top-hat rail.

3. Indicator LEDs

There are two LEDs on the front of the device, which have the following meaning:



Marking	Color	Meaning
ON	Green	The LED is on when the power supply is on
I²	Red	The LED is on when the signal is outside the normal measuring range of 4...20 mA

Fig. 1

1. Safety instructions

1.1 Symbols

The symbols used in this operating instruction indicate dangers and they have the following meanings:

Non-compliance could result in functional failures.

Non-compliance could result in functional failures and injury to personnel.

1.2 Proper use

- The device is a transducer power supply for the safe isolation of 4...20 mA signal circuits.
- The device is intended for mounting in industrial installations and fulfils the requirements according to EN 61010-1.

4. Installation instructions



The maximum ambient temperature must be observed.
There must be sufficient circulation of air.
Neighboring devices that produce heat must be mounted at a suitable distance.
The preferred mounting method is on a horizontal rail.
The device must be protected from vibrations.

5. Mounting the device

The SINEAX B 812 device is mounted on a top-hat rail.
Snap the device housing onto the top-hat rail (EN 50 022) (see Fig. 2).

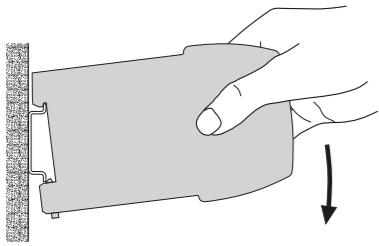

Fig. 2. Mounting on a top-hat rail 35×15 or 35×7.5 mm.

6. Removal of the device

Remove the device from the top-hat rail as shown in Fig. 3.

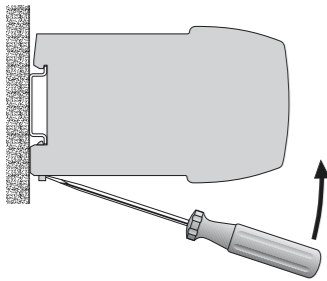

Fig. 3

7. Dimension drawings

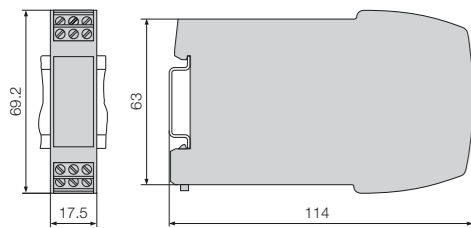

Fig. 4. The SINEAX B 812 in a top-hat rail housing P12/17 mounted on a top-hat rail (35 × 15 mm or 35 × 7.5 mm to EN 50 022) with fixed connection screw terminals.

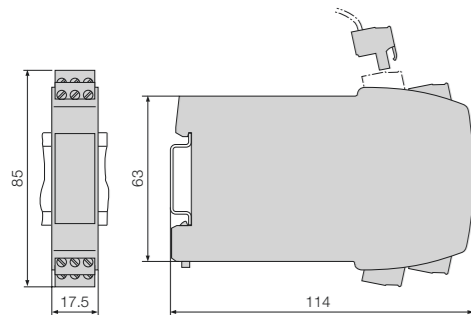

Fig. 5. The SINEAX B 812 in a top-hat rail housing P12/17 St mounted on a top-hat rail (35 × 15 mm or 35 × 7.5 mm to EN 50 022) with plug-in connection screw terminals.

8. Electrical connections



- Terminals without internal connections (1, 2, 3, 6 and 12) must remain free and must not be used for other purposes.
- Ex devices may only be operated with a DC power supply of upto $U_m = 125$ V DC.

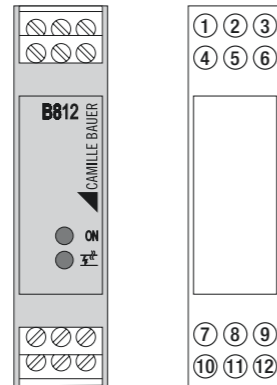
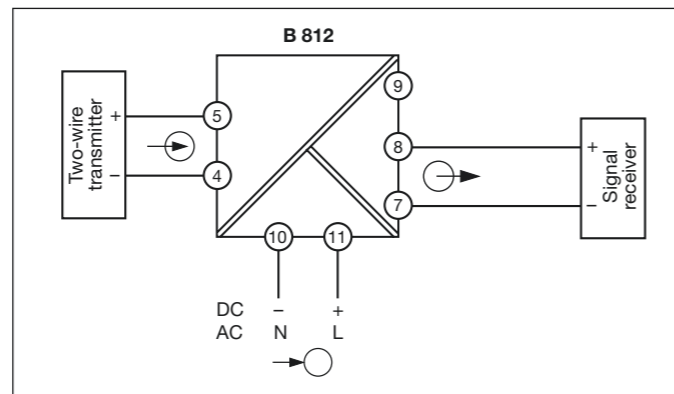

Fig. 6. Arrangement of the terminals

8.1 Connection without HART® terminal



8.2 Connection with HART® terminal



For the correct functioning of the communication, a 250 Ω communication resistor is required in series with the measuring circuit. Please observe that the maximum load on the B 812 output resulting from additional devices and the resistance of the wires is not exceeded.

Internal communication resistor

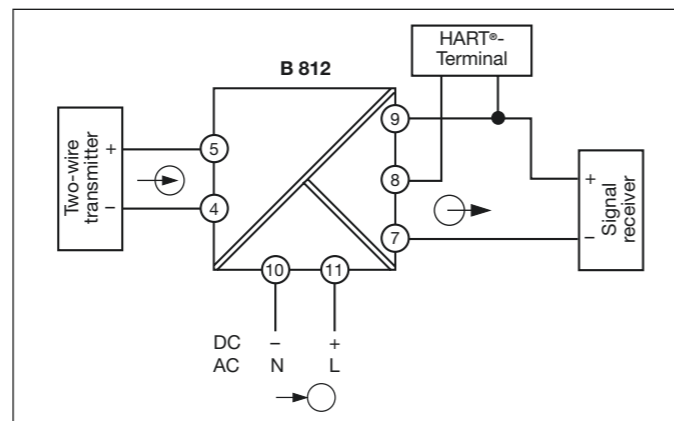

External communication resistor

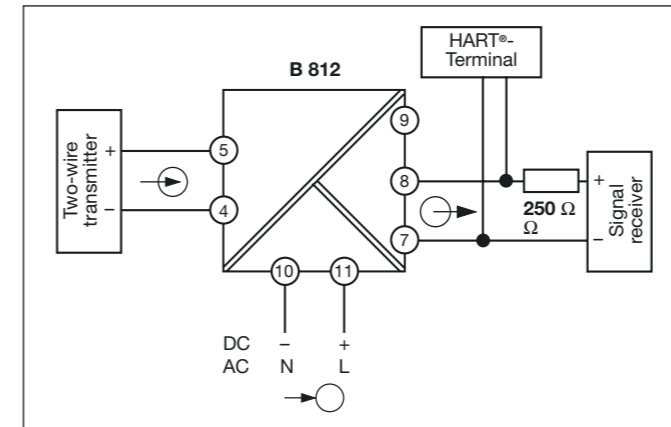

9. Commissioning

The installation and wiring must be checked before commissioning, and in particular the permitted power supply voltage must be checked (see the rating label).

10. Technical data

10.1 Input

Signal range	4...20 mA
Power supply voltage ($I = 20$ mA)	18.0 V ± 1 V
No-load voltage ($I = 0$ mA)	25.5 V ± 1 V
Short circuit current limitation	25 mA ± 2 mA
Source resistance	330 Ω ± 5 Ω
Open circuit detection	3.5 mA ± 0.1 mA
Short circuit detection	21.2 mA ± 0.2 mA

10.2 Intrinsically safe input (Ex version)

Provisional data

U_o	28,2 V
I_o	95 mA
P_o	0.67 W
Type of protection	[EEx ia] IIC
Marking	Ⓔ II (1) GD

10.3 Output

Signal range	4...20 mA
No load voltage ($I = 0$ mA)	17.0 V ± 1 V
Internal communication resistor R_c	250 Ω
Permitted load	0...750 Ω 0...500 Ω (via R_c)

10.4 Accuracy

Reference conditions	$T_{amb} = 23^\circ\text{C}$, load = 300 Ω Warm up time 20 minutes Power supply = 24 V DC or 230 V AC Range = 16 mA ± 100%
Error tolerance incl. linearity error under reference conditions	± 0.2%
Effect of output load	< 0.1%
Temperature effect	< 0.1% / 10°K
Effect of power supply	< 0.05%

10.5 Power supply

Universal power supply for DC and AC

	Low-range version	High-range version
Voltage range AC/DC (absolute limits)	20 – 70 V	60 – 265 V *)
Switching-on current \hat{I} / τ	2.5 A / 1.0 ms at 24 V DC	20 A / 0.15 ms at 325 V DC
Frequency range AC	45 ... 400 Hz	
Power consumption max.	3 VA / 2.4 W	

*) Voltages > 125 V DC require external protection with max. 10 A trip current. For the Ex version, the data in the EC type examination certificate are valid ($U_m = 253$ V AC or 125 V DC).

10.6 Transfer

Signal current over-range	10 %
Response time	< 0.3 ms
HART®	Transparent for HART® signals in both directions

10.7 Galvanic isolation

All three circuits (input / power supply / output) are galvanically isolated from each other.

Electrical safety	To IEC / EN 61010-1 Double isolation Measuring and overvoltage category III Contamination level 2
Working voltage	< 300 V
Test voltage	3.6 kV / 50 Hz / 1 minute

10.8 Ambient conditions

Operating temperature	- 20 ... +50 °C
Storage temperature	- 20 ... +70 °C
Rel. humidity average	≤ 75%
Protection type	IP 20, EN 60 523
EMV	EN 61 000-6-2 / -4

10.9 Various

Weight	100 g
Terminal cross section	2.5 mm²
Plug-in terminals (alternative)	Coded to prevent incorrect connection