

## 8. Commissioning and maintenance

The device is in operation as soon as the input signal E is connected.  
The signal isolator requires no maintenance.

## 9. Releasing the signal isolator

Release the signal isolator from a top-hat rail as shown in Fig. 12 or from the adapter as shown in Fig. 13.

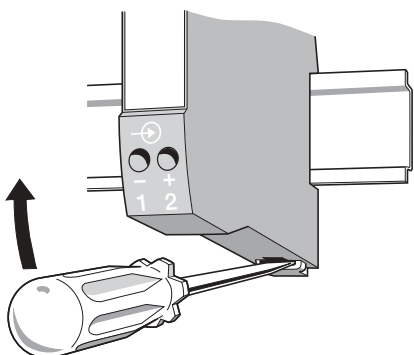

Fig. 12

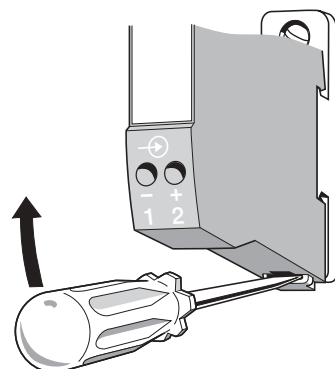

Fig. 13

## 10. Dimensional drawings

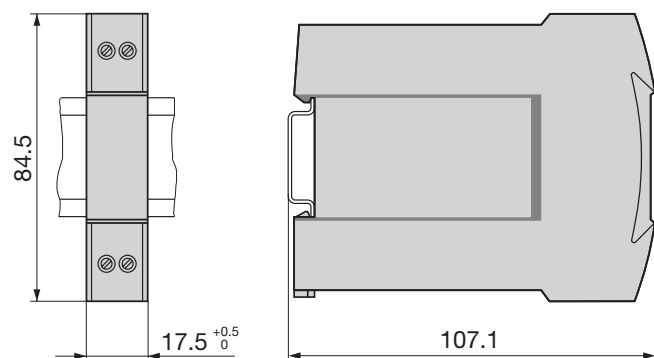

Fig. 14. SINEAX SI 815-5.... (housing **N17**) clipped onto a top-hat rail (35 x 7.5 or 35 x 15 mm, acc. to EN 50 022).

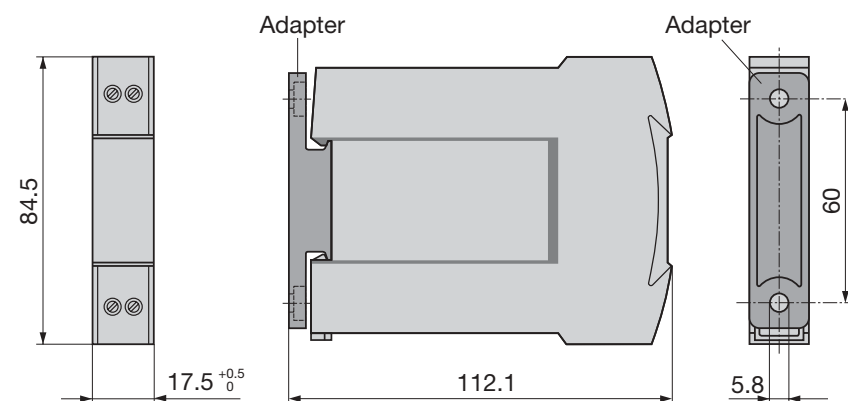

Fig. 15. SINEAX SI 815-5.... (housing **N17**) with adapter for wall mounting.



The following symbols in the Operating Instructions indicate safety precautions which must be strictly observed:



## Contents

1. Read first and then ...	1
2. Scope of supply	1
3. Brief description	1
4. Specification and ordering information	1
5. Technical data	2
6. Mounting	2
7. Electrical connections	3
8. Commissioning and maintenance	4
9. Releasing the signal isolator	4
10. Dimensional drawings	4

## 1. Read first and then ...



The proper and safe operation of the device assumes that the Operating Instructions are **read carefully** and the safety warnings given in the sections

### 6. Mounting

### 7. Electrical connections

are **observed**.

The device should only be handled by appropriately trained personnel who are familiar with it and authorised to work in electrical installations.

Unauthorized repair or alteration of the unit invalidates the warranty.

## 2. Scope of supply

Signal isolator (Fig. 1)

1 Adapter (Fig. 1) for wall mounting

1 copy Operating Instructions (Fig. 2) in English, French, German

1 Ex approval (Fig. 2), only for Ex version devices



Fig. 1



Fig. 2

## 3. Brief description

The signal isolator **SINEAX SI 815-5** serves to electrically insulate the 4...20 mA input circuit of a two-wire transmitter. It performs two tasks at the same time. Firstly it provides electrical insulation and secondly it conducts the power supply needed for measurement to the two-wire transmitter without injecting into the circuit itself. Thus the isolator does not require a power supply connection itself.

Some versions of the SINEAX SI 815-5 are **designed for FSK communication**. They are used in conjunction with "intelligent" two-wire transmitter which are capable of dialogue and operation according to the FSK principle and the HART or user-specific protocol.

The series also includes "intrinsically safe" versions [Ex ia] IIC with an intrinsically safe measurement/supply circuit. These operate in conjunction with intrinsically safe two-wire transmitters located in explosion hazard areas.

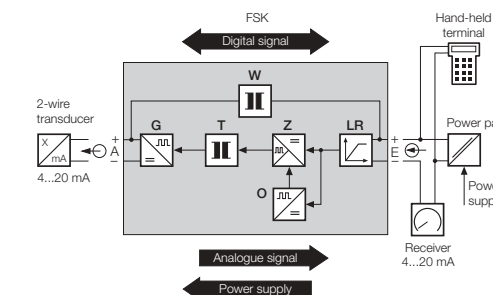



Fig. 3. Block diagram.

## 4. Specification and ordering information

Order Code 815 -	5	1		
<b>1. Mechanical design</b> Housing N17	5	1	1	1
<b>2. Version</b> Standard (non-Ex) Output signal <b>non-intrinsically safe</b> [Ex ia] IIC Output signal <b>intrinsically safe</b>		1	2	
<b>3. Number of isolation and transmission channels</b> 1 channel (interface)				1
<b>4. Field communications protocol</b> Without FSK communication With FSK communication				0 1
<b>5. Climatic rating</b> Standard climatic rating Improved climatic rating				0 1

## 5. Technical data

**Input signal E<sup>1</sup>**   
 (Input circuit between signal isolator and power pack)  
 DC current signal I<sub>E</sub>: 4...20 mA  
 Voltage U<sub>E</sub>: 12...30 V DC  
 Overload capacity: ≤ 50 mA continuous

**Output signal A<sup>1</sup>**   
 (Input circuit between signal isolator and 2-wire transmitter)  
 DC current signal I<sub>A</sub>: 4...20 mA  
 Voltage U<sub>A</sub> (for I<sub>E</sub> = 20 mA and U<sub>E</sub> = 22 V):

> 19.3 V	with standard (non-Ex) version, not designed for communications protocol
> 18.5 V	with standard (non-Ex) version, designed for FSK communication
> 14.3 V	with Ex versions, not designed for communications protocol
> 13.3 V	with Ex versions, designed for FSK communication

Voltage drop U<sub>V</sub> = U<sub>E</sub> - U<sub>A</sub> (at U<sub>E</sub>) 12...22 V:

< 2.7 V	with standard (non-Ex) version, not designed for communications protocol
< 3.5 V	with standard (non-Ex) version, designed for FSK communication
< 7.7 V	with Ex versions, not designed for communications protocol
< 8.7 V	with Ex versions, designed for FSK communication

Residual ripple: <20 mV ss (120 kHz)  
 Time constant: Approx. 5 ms

### Accuracy data

Error: <±0.2%  
 (Reference value 20 mA of output signal, including typical linearity error < ± 0.1%)

### Ambient conditions

Climatic rating: Climate class 3Z acc. to VDI/VDE 3540  
 Operating temperature: -25 to +55 °C  
 -20 to +55 °C (for the Ex versions: output signals "intrinsically safe")  
 Storage temperature: -40 to +70 °C  
 Annual mean relative humidity: ≤75% standard climatic rating  
 ≤95% improved climatic rating  
 Seismic test: 5 g, <200 Hz, 2 h in each of 3 directions  
 Shock test: 50 g, 10 shocks in each of 3 directions

## 6. Mounting

The SINEAX SI 815-5 can be mounted either on a top-hat rail or directly onto a wall or mounting plate using the adapter (standard accessory).

 Make sure that the ambient temperature stays within the **permissible limits**:  
 -25 and +55 °C for standard instruments  
 -20 and +55 °C for instruments in **Ex** version!

### 6.1 Top-hat rail mounting

Simply clip the device onto the top-hat rail (EN 50 022) (see Fig. 4).

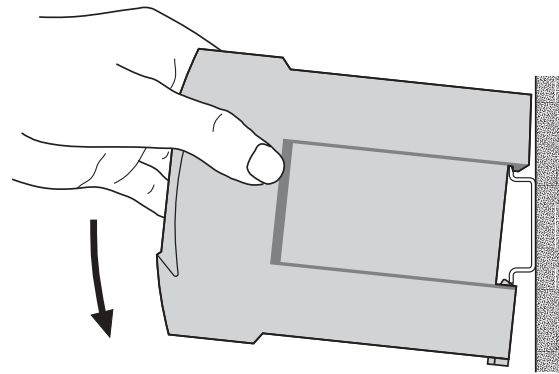

Fig. 4. Mounting on top-hat rails 35 × 15 or 35 × 7.5 mm.

### 6.2 Wall mounting

Drill 2 holes in the wall or panel as shown in the drilling pattern (Fig. 5). Now secure the adapter (standard accessory) to the wall or panel using two 5 mm diameter screws (Fig. 6). Clip the device onto the adapter (Fig. 7).

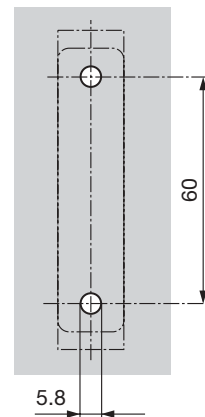

Fig. 5. Drilling pattern.

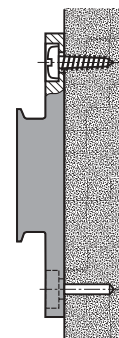

Fig. 6. Adapter mounted on wall.

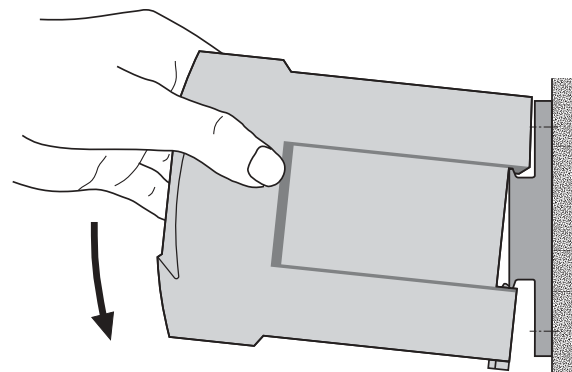

Fig. 7. Mounting on the adapter.

## 7. Electrical connections

The electrical connections are made to screw terminals which are easily accessible from the front of the signal isolator (see Fig. 9) and can accommodate wire gauges up to 2,5 mm<sup>2</sup>.



Make sure that the cables are not live when making the connections!



In the case of "Intrinsically safe" explosionproof version, the supplementary information given on the type examination certification, the EN 60 079-14 and also local regulations applicable to electrical installations in explosion hazard areas must be taken into account.



Note that, ...

... the required electrical insulation and transmission data agree with the data on the nameplate of the SINEAX SI 815-5 (input signal and output signal, see Fig. 8)!

... the input and output cables should be twisted pairs and run as far as possible away from heavy current cables!

Connect the input E and output A leads and according to Fig. 9.

### Signal isolator in housing N17 with one isolation and transmission channel

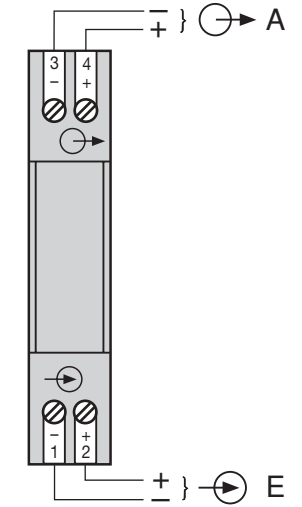

Fig. 9. SINEAX SI 815-511... Standard (non-Ex) version and SINEAX SI 815-521... Ex version (output signal A "intrinsically safe").

### 7.1 Connection of the hand-held-terminals HHT

The FSK transmission versions of the isolation transformers SINEAX SI 815-5111. and SI 815-5.11. can relay a frequency modulated digital signal in both directions in addition to the analogue signal and the auxiliary supply. Connect the hand-held terminal HHT as shown in Figures 10 and 11.



The burden of the signalling circuit must be as least 250 Ω. The burden is represented in Figures 10 and 11 by the resistor R<sub>B</sub>.

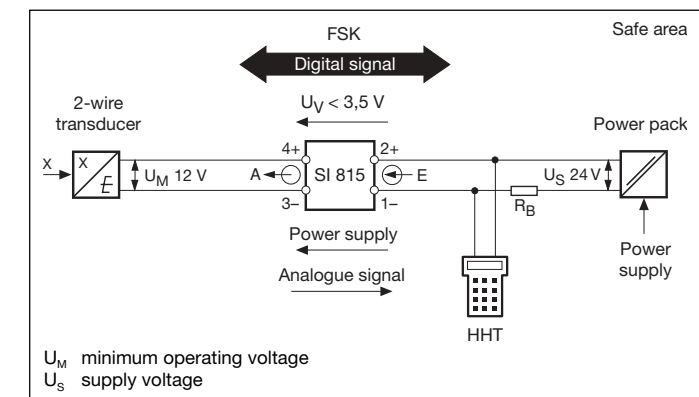

Fig. 10. SINEAX SI 815-5111. Standard (non-Ex) version, designed for FSK communication, frequency 500 Hz ... 35 kHz.

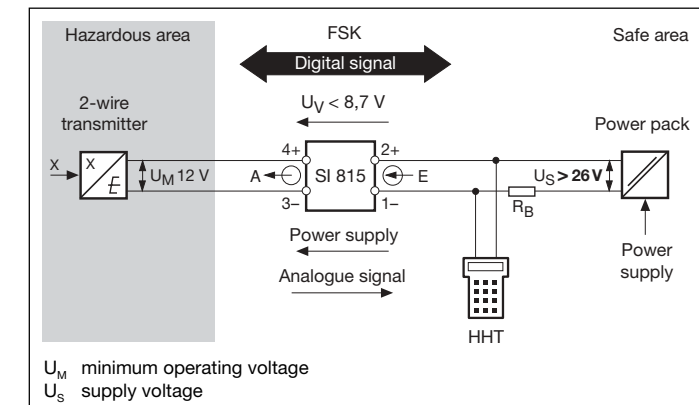

Fig. 11. SINEAX SI 815-5.11. Ex version, (output signal A "intrinsically safe"), designed for FSK communication, frequency 500 Hz ... 35 kHz.

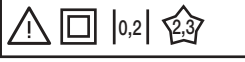



<b>SINEAX SI 815</b>	Passiver DC-Signaltrenner Passive DC signal isolator	Camille Bauer AG Aargauerstr. 7 CH-5610 Wohlen Switzerland
Type: 815-51110	Mat: 999295/1416280	Manufactured: 1998
	Tamb 55°C	
 4...20 mA 12V/30V HART		
 4...20 mA		

Fig. 8. Example of a nameplate.

<sup>1</sup> "Input" and "output" in this case refer to the direction of power supply flow.