



Input: mVDC, ± 10 to 0-10 VDC, 0-1 mA to 4-20 mA
2 Outputs: mVDC, ± 10 to 0-10 VDC, 0-1 mA to 4-20 mA

- One Input Dual Output Signal Splitter
- 2000 V Power/Input/Output/Channel Isolation
- Full Isolation Eliminates Ground Loops
- Input and Output LoopTracker® LEDs
- Functional Test Pushbutton for Each Channel
- Independent Zero and Span for Each Channel

Applications

- Isolate, Split, Rescale Process Signals
- Send One Process Signal to Two Locations
- Interface Panel Meters, Recorders, Data Acquisition, PLCs, DCS Systems, SCADA Systems

Specifications

Input and Output Ranges

Factory Configured—Please specify range
 Consult factory for special ranges

Voltage: 0-50 mVDC, 0-100 mVDC, 0-5 VDC, 0-10 VDC

Bipolar Voltage: ± 5 VDC, ± 10 VDC

Current: 0-1 mA, 0-20 mA, 4-20 mA (1000 Ω maximum per channel)
 Sinking input and sourced outputs for current

Input Voltage Burden (Current)

1.25 VDC maximum

Output Linearity

Better than $\pm 0.1\%$ of span

Output Ripple and Noise

Less than 10 mV_{RMS}

Output Zero and Span

multi-turn zero and span potentiometers to compensate for load and lead variations

Independent zero and span potentiometers for each output channel
 $\pm 15\%$ of span adjustment range typical

Low interaction zero/span; <0.001 ppt

LoopTracker

Variable brightness LEDs indicate input/output loop level and status

Functional Test Buttons

Sets output to test level when pressed. One per output channel.

Factory set to drive output to approximately 50% of span

Response Time

70 milliseconds typical. Consult factory for other response times.

Isolation

2000 V_{RMS} minimum

Full isolation: power to channel, input to output, channel to channel

Common Mode Rejection

120 dB minimum

Ambient Temperature Range

-10°C to +60°C operating ambient

Temperature Stability

Better than $\pm 0.04\%$ of span per °C

Case Material

Polycarbonate: gray UL #94V-1 housing and black UL #94V-2 terminals

Power Supplies

Input power supply fuse protected and fully isolated

Standard: 115 VAC $\pm 10\%$, 50/60 Hz, 5 W max., linear type

A230 option: 230 VAC $\pm 10\%$, 50/60 Hz, 5 W max., linear type

DD option: 9-30 VAC/VDC, 5 W typical, switching type



Removable Plugs
for Easy Hookup



DC Input

Description and Features

The API 4393 DIN IsoSplitter accepts one analog DC voltage or current input and provides two optically isolated analog DC outputs that are linearly related to the inputs. The input signal is filtered, amplified, split, and then passed through an opto-coupler to the output stage. The two isolated output channels provide an economical solution where more than one output device is connected to the same input signal.

Typical applications include isolation, output splitting, output device separation and redundancy (i.e. to prevent failure of the entire loop if one device fails), or a combination of the three. The optical isolation between the input and outputs make this module useful for ground loop elimination, common mode signal rejection or noise pickup reduction.

This product is designed to function effectively in electrically noisy industrial environments. It is designed to interface with and provide signal compatibility with recorders, data loggers, computers programmable logic controllers, and process transmitters.

API exclusive features include two LoopTracker LEDs and Functional Test Pushbuttons for each channel. The LoopTracker LEDs (Green for input, Red for output) vary in intensity with changes in the process input and output signals and can provide a quick visual picture of your process loop at all times.

The functional test pushbutton provides a fixed output (independent of the input) when held depressed. This output is factory set to approximately 50% of the output span. Both the LoopTracker LEDs and functional test pushbutton greatly aid in saving time during initial startup and/or troubleshooting. The modules clip to an industry standard 35 mm DIN rail or they can be surface mounted.

Factory Configured—Please specify input/output ranges and options

API 4393 DIN IsoSplitter, 115 VAC powered

API 4393 DIN A230 IsoSplitter, 230 VAC powered

API 4393 DD IsoSplitter, 9-30 VAC/VDC powered

See API 4393 L1 data sheet for more sink/source versions

Options—Add to end of model number

DF Fast response time, consult factory

U Conformal coating for moisture resistance

Accessories—Order as separate line item

API TK36 DIN rail, 35 mm W x 39" L, aluminum



API 4393 DIN IsoSplitter® Installation and Setup

ELECTRICAL CONNECTIONS

WARNING! All wiring must be performed by a qualified electrician or instrumentation engineer. See wiring examples at right or consult factory for assistance.

The housing can be clipped to a standard 35 mm DIN rail or surface mounted. Each product is factory configured to your exact input and output requirements as indicated on the product label. The power supplies are fuse protected and the unit may be returned to API for fuse replacement.

Power Input Terminals – The white label on the side of the API module will indicate the power requirements. AC power is connected to terminals 12 and 13. For DC-powered versions positive (+) is connected to terminal 13 and negative (-) is connected to terminal 12.

Signal Input Terminals – Polarity must be observed when connecting the signal input. The positive connection (+) is applied to terminal 9 and the negative (-) is applied to terminal 10.

Signal Output Terminals – Polarity must be observed when connecting the signal output to the load. The positive connection (+) for channel 1 is connected to terminal 6 and the negative (-) is connected to terminal 7. The positive connection (+) for channel 2 is connected to terminal 3 and the negative (-) is connected to terminal 2.

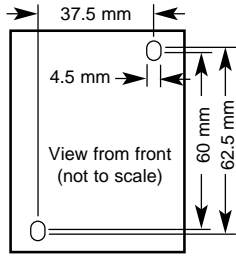

Surface mounting dimensions

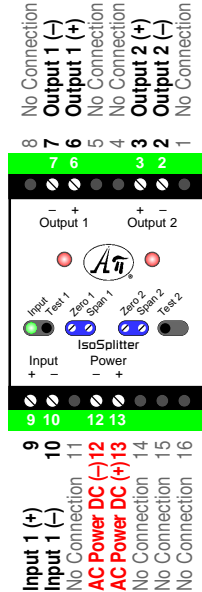

TYPICAL APPLICATION

The API 4393 DIN IsoSplitter is useful where a 4-20 mA signal must be independently output to two devices. The output from a pressure transmitter needs to be monitored in two separate locations. The DCS is used for the control system and another device is used for data acquisition. The API 4393 DIN IsoSplitter provides two independent 4-20 mA loops from one input and provides isolation for each loop.

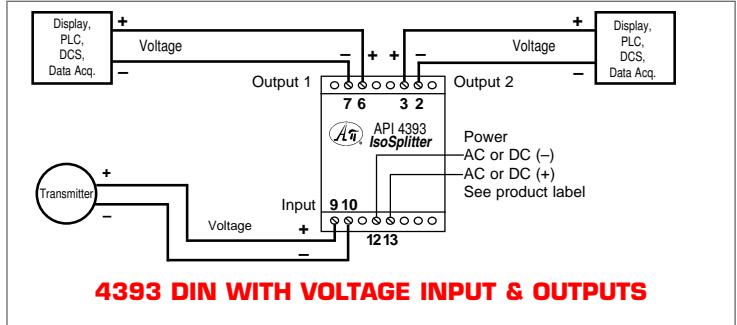
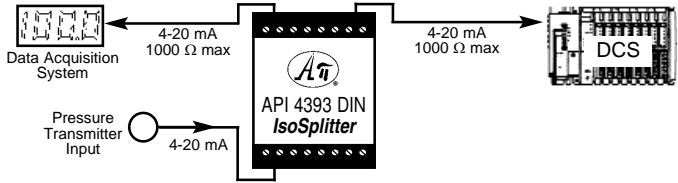

4393 DIN WITH VOLTAGE INPUT & OUTPUTS

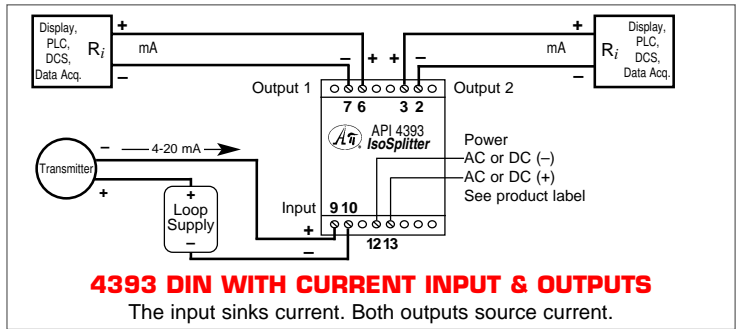

4393 DIN WITH CURRENT INPUT & OUTPUTS

The input sinks current. Both outputs source current.

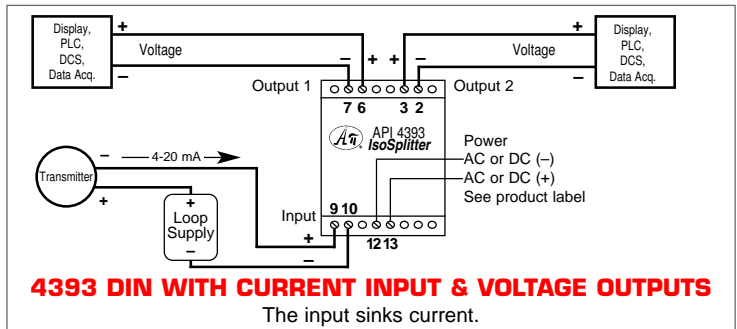

4393 DIN WITH CURRENT INPUT & VOLTAGE OUTPUTS

The input sinks current.

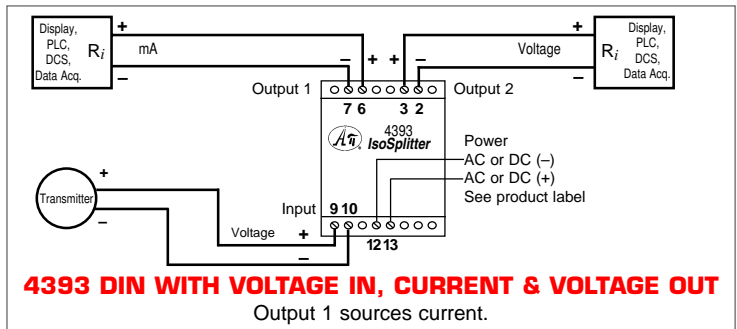

4393 DIN WITH VOLTAGE IN, CURRENT & VOLTAGE OUT

Output 1 sources current.

CALIBRATION

Front-mounted Zero and Span potentiometers for each channel can be used to compensate for load and lead variations.

1. Apply power to the module and allow a minimum 30 minute warm up time.
2. Using an accurate calibration source, provide an input to the module equal to the minimum input required for the application.
3. Using an accurate measurement device for the output, adjust the Zero potentiometer for the exact minimum output desired. The Zero control should only be adjusted when the input signal is at its minimum. This will produce the corresponding minimum output signal. Example: for 4-20 mA output, the Zero control will provide adjustment for the 4 mA or low end of the signal.
4. Set the input at maximum, and then adjust the Span pot for the exact maximum output desired. The Span control should only be adjusted when the input signal is at its maximum. This will produce the corresponding maximum output signal. Example: for 4-20 mA output, the Span control will provide adjustment for the 20 mA or high end of the signal.
5. Repeat adjustments for maximum accuracy.
6. Repeat adjustments for second channel.

TEST BUTTONS

The Test pushbuttons are factory set to provide approximately 50% output. When depressed they will drive the output side of the loop with a known good signal that can be used as a diagnostic aid during initial start-up or troubleshooting. When released, the output will return to normal.

OPERATION

GREEN LoopTracker® Input LED – Provides a visual indication that a signal is being sensed by the input circuitry of the module. It also indicates the input signal strength by changing in intensity as the process changes from minimum to maximum. If the LED fails to illuminate, or fails to change in intensity as the process changes, check the module power or signal input wiring. Note that it may be difficult to see the LEDs under bright lighting conditions.

RED LoopTracker output LED – Provides a visual indication that the output signal is functioning. It becomes brighter as the input and the corresponding output change from minimum to maximum. For current outputs, the RED LED will only light if the output loop current path is complete. For either current or voltage outputs, failure to illuminate or a failure to change in intensity as the process changes may indicate a problem with the module power or signal output wiring.