

KINAX SR 719

Programmable Transmitter for Position Feedback

Position transmitter with NAMUR valve fitting



Application

The position feedback transmitter **KINAX SR 719** (Figs. 1 and 2) is used to measure and transmit linear displacement (stroke) on various types of control valves and other control devices. The output is a load-independent DC signal. The position feedback transmitter consists of a KINAX angle transmitter and a reduction gear which converts a linear movement into an angle of rotation of 0 ... 90°. Both parts are contained in a robust cast aluminium housing. The mounting part to the control valve is based on NAMUR recommendations, (standards working group for measuring and process control in the chemical industry).

Features / Benefits

- Measuring input: Movement, stroke

Measured variable	Measuring range limits
Movement, stroke	0 ... 10 to 0 ... 140 mm

- Measuring output: DC current signal (2-wire connection)
- Capacitive scanning system / Non-wearing
- Simulation of measured values / The testing of the subsequent device chain is already possible during the installation phase
- Measured value acquisition / Display of the instantaneous value and a trend graph of the measured value on the screen
- Adjustment / Independent fine adjustment of the analog output, zero position and measuring range
- Characteristic of the output value / Programmable as a linear, V-characteristic, or any characteristic curve
- Unit in field type housing in cast aluminium with NAMUR mounting part for fitting to control valve
- Patented measuring method

Layout and mode of operation

The pick-up of the stroke movement is made by means of a slotted lever. The adaption to strokes between 10 and 140 mm is made with an external lever transmission and by an internal gear ratio. The external lever transmission can be adjusted in such a way, that the internal cam shaft makes an angle of rotation of approx. 90° for a full stroke. By means of the built-in transmitter for angular position, the KINAX 2W2, this angular position is transformed into a DC current signal proportional to the measured value.

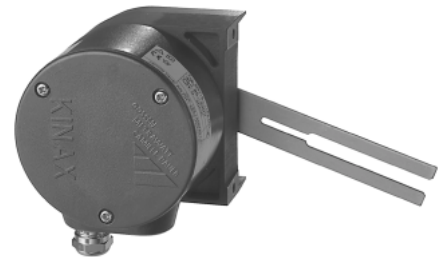

Fig. 1. Position feedback transmitter KINAX SR 719 showing the operating lever in the lower zero position, corresponding output current 4 mA.



Fig. 2. Position feedback transmitter KINAX SR 719 showing the operating lever in the upper zero position, corresponding output current 4 mA.

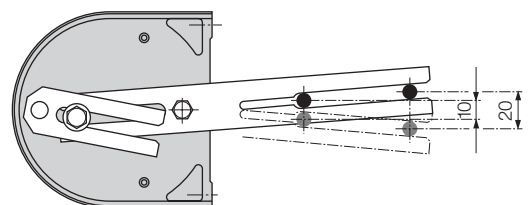

Fig. 3. Operating lever set for minimum operating angle.

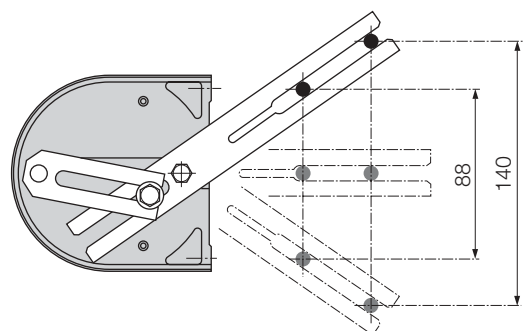

Fig. 4. Operating lever set for maximum operating angle.

KINAX SR 719

Programmable Transmitter for Position Feedback

The incorporated KINAX 2W2 consists of 2 main parts: the differential screen capacitor D and the electronic circuitry E (Fig. 5).

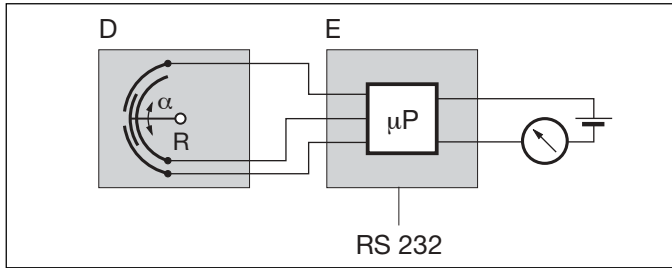

Fig. 5. Block diagram.

The angular deflection α of the axle is transferred to the rotor R of the differential screen capacitor with the aid of a mechanical coupling. It is then converted into a change of capacitance proportional to the angle.

All changes to the position of the rotor result in a change in the capacitance at the input to the microprocessor. This is transformed into a DC current signal proportional to the measured value.

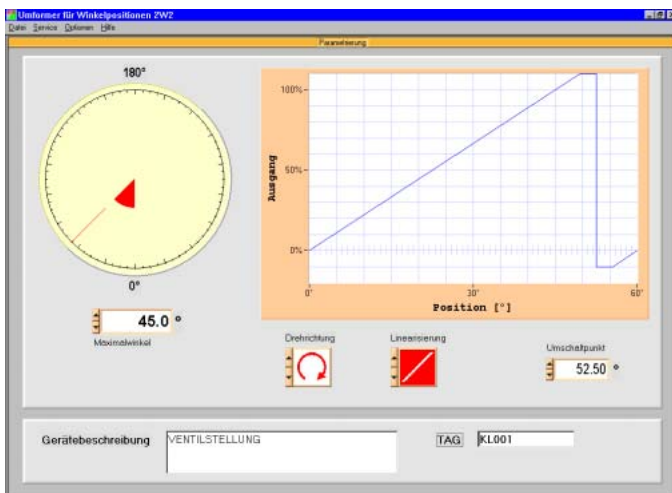

Fig. 6. Print screen example of the menu-controlled programming software.

Programming

A PC, the programming cable PK 610 plus ancillary cable and the configuration software 2W2 are required to program the transmitter. (Details of the programming cable and the software are to be found in the separate data sheet: PK 610 Le.)

The connections between "PC \leftrightarrow PK 610 \leftrightarrow KINAX SR 719" can be seen from Fig. 7. The transmitter can be programmed either with or without the power supply connected.

The software 2W2 is supplied on one CD and runs under Windows 95 or higher.

The programming cable PK 610 adjusts the signal level between the PC and the transmitter KINAX SR 719.

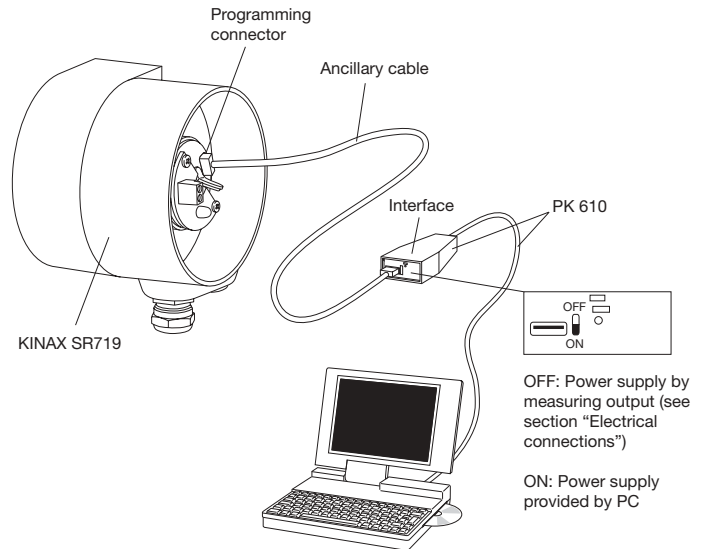

Fig. 7. Example of the set-up for programming a KINAX SR 719 without the power supply. For this case the switch on the interface must be set to «ON».

Technical data

Measuring input

Measured quantity: Movement, stroke
 Measuring range limits: 0 ... 10 to 0 ... 140 mm

Measuring output

Power supply: H = 12 to 33 V DC
 Protected against wrong polarity
 Output variable I_A : Load-independent DC current, proportional to the input angle
 Zero point correction: Approx. $\pm 5\%$
 Span adjustment: Approx. $\pm 5\%$
 Current limitation: I_A max. 40 mA
 Standard ranges: 4...20 mA, 2-wire connection

External resistance (load): $R_{\text{ext max.}} [\text{k}\Omega] = \frac{H [\text{V}] - 12 \text{ V}}{I_A [\text{mA}]}$

H = DC power supply
 I_A = End value of output variable

Load max. [Ω] with output 20 mA

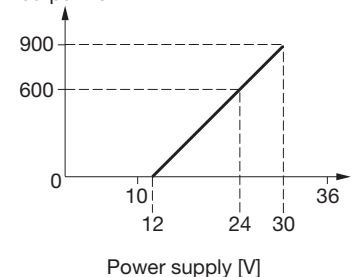

KINAX SR 719

Programmable Transmitter for Position Feedback

Residual ripple in output current: < 0.3% p.p.
 Response time: < 5 ms

Possible adjustability of the built-in KINAX 2W2 > 50...350°
 Linear characteristic
 The measuring range is set to approx. 0...90°.

Programming connector

Interface: Serial interface

Accuracy data

Reference value: Measuring span
 Basic accuracy: Error limits at reference conditions $\leq \pm 0.5\%$
 Reproducibility: < 0.2%

Influence effects (maxima) (included in basic error)

Dependence on external resistance ΔR_{ext} max. $\pm 0.1\%$
 Power supply influence $\pm 0.1\%$

Reference conditions

Ambient temperature $23\text{ }^{\circ}\text{C} \pm 2\text{ K}$
 Power supply 18 V DC
 Output burden $0\ \Omega$

Additional error (maxima)

Temperature influence ($-25\dots+75\text{ }^{\circ}\text{C}$) $\pm 0.2\% / 10\text{ K}$
 Bearing play influence $\pm 0.1\%$

Additional errors (cumulative)

Output characteristics	Definitions	Additional error
<p>simple "V" characteristic</p>	<p>Angle max. = MW Angle min. = 0°</p>	$f = \left(\frac{0.18^{\circ}}{\text{MW}} \times 100 \right)$
<p>"V" characteristic with offset</p>	<p>MS = (angle max.) - (angle min.) Angle max. = \pm final angle Angle min. = $> 0^{\circ}$</p>	$f = \left(\frac{0.25^{\circ}}{\text{MS}} \times 100 \right)$
<p>any characteristic</p>	<p>MS = (angle max.) - (angle min.)</p>	$f = \left(\frac{0.25^{\circ}}{\text{MS}} \times 100 \right)$

KINAX SR 719

Programmable Transmitter for Position Feedback

Mechanical withstand

Permissible vibrations: 20 ... 200 Hz,
10 g continuous, 15 g for 2 h
200 ... 500 Hz,
5 g continuous, 10 g for 2 h

Shock: 3 x 50 g every 10 impulses
in all 3 axes

Mounting position: Any

Housing data

Material: Metal (aluminium)

Cable glands: 1 cable gland PG 11 in metal

There are 2 screw terminals in the rear cover for connecting the electrical leads.

The screw terminals accept gauges up to max. 1.5 mm² and are accessible after removing the cover.

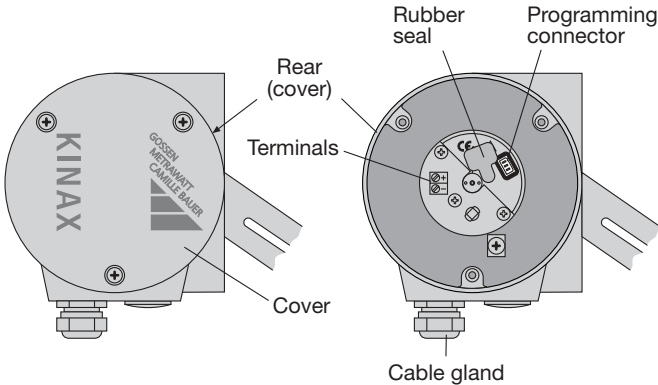

Fig. 8. KINAX SR 719 with screw terminals and cable gland.

Mounting: Directly
or
Fixing with NAMUR mounting part
(see Figs. 11 and 12)

Weight: Approx. 1.1 kg

Regulations

Electromagnetic compatibility: The standards DIN EN 50 081-2 and DIN EN 50 082-2 are observed

impulse voltage withstand: 1 kV, 1.2/50 μs, 0.5 Ws
IEC 255-4, Cl. II

Housing protection: IP 54 acc. to IEC 529

Test voltage: all connections to housing
500 Veff., 50 Hz, 1 ain.

Permissible common-mode voltage: 100 V, 50 Hz

Environmental conditions

Climatic rating: Standard version
Temperature - 25 to + 75 °C
Annual mean relative humidity ≤ 90%
or
Version with improved climatic rating
Temperature - 40 to + 75 °C
Annual mean relative humidity ≤ 95%

Transportation and storage temperature: - 40 to 80 °C

Table 2: Specification and ordering information

Order Code 719 -						
Features, Selection	*SCODE	no-go	1	0	1	0
1. Version 1) Standard			1			
2. Mounting position Lever in spring loaded position (corresponding to output 4 mA) 0) Lower end position 1) Upper end position Attention! Later changes not possible.			. 0 1		
3. Climatic rating 0) Standard climatic rating 1) Improved climatic rating	G		. . 0 1		
4. Mounting set 0) Without mounting set 1) With mounting set acc. to NAMUR			. . . 0 1		

KINAX SR 719

Programmable Transmitter for Position Feedback

Electrical connections

2-wire connection

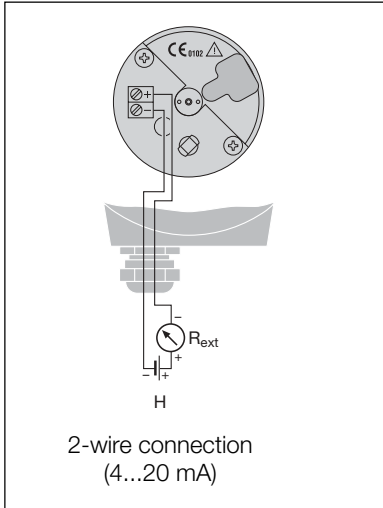

Standard accessories

- 1 Operating Instructions in three languages: German, French, English
- 1 Blank label

Table 4: Accessories and spare parts

Description	Order No.
Programming cable PK 610 	137 887
Ancillary cable 	141 440
Configuration software 2W2 Windows 95 or higher on CD in German and English (Download free of charge under http://www.camillebauer.com) In addition, the CD contains all configuration programmes presently available for Camille Bauer products	146 557

KINAX SR 719

Programmable Transmitter for Position Feedback

Dimensional drawings

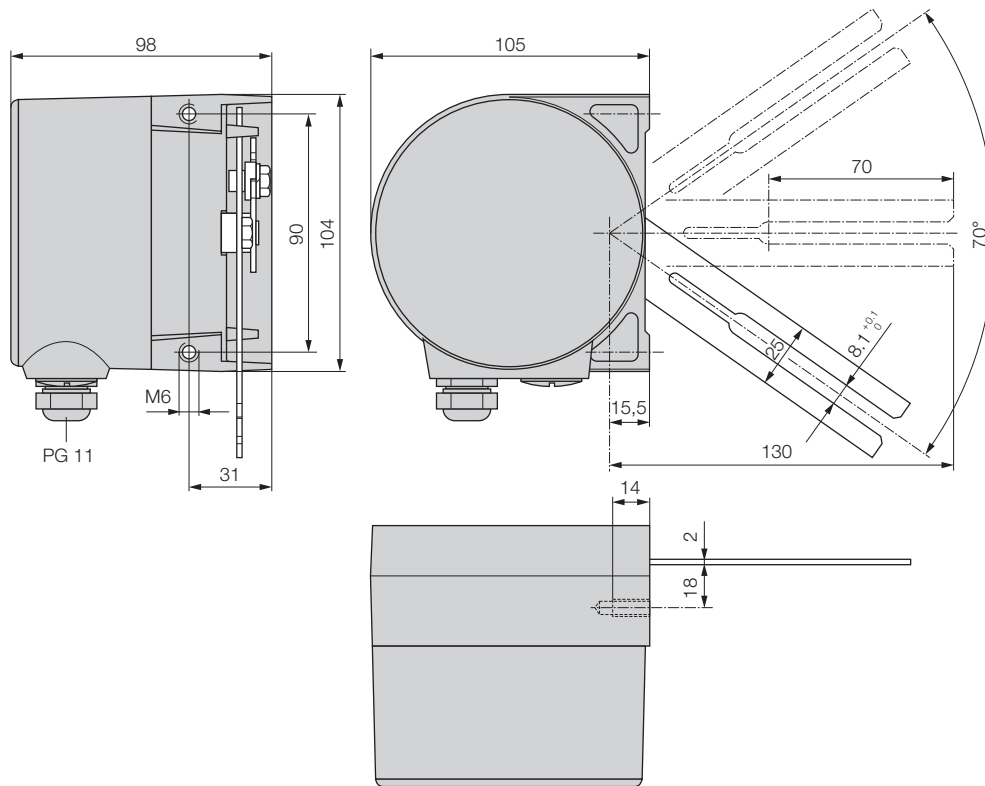

Fig. 9. Position of the KINAX SR 719 operating lever in the lower zero position, corresponding output current 4 mA.

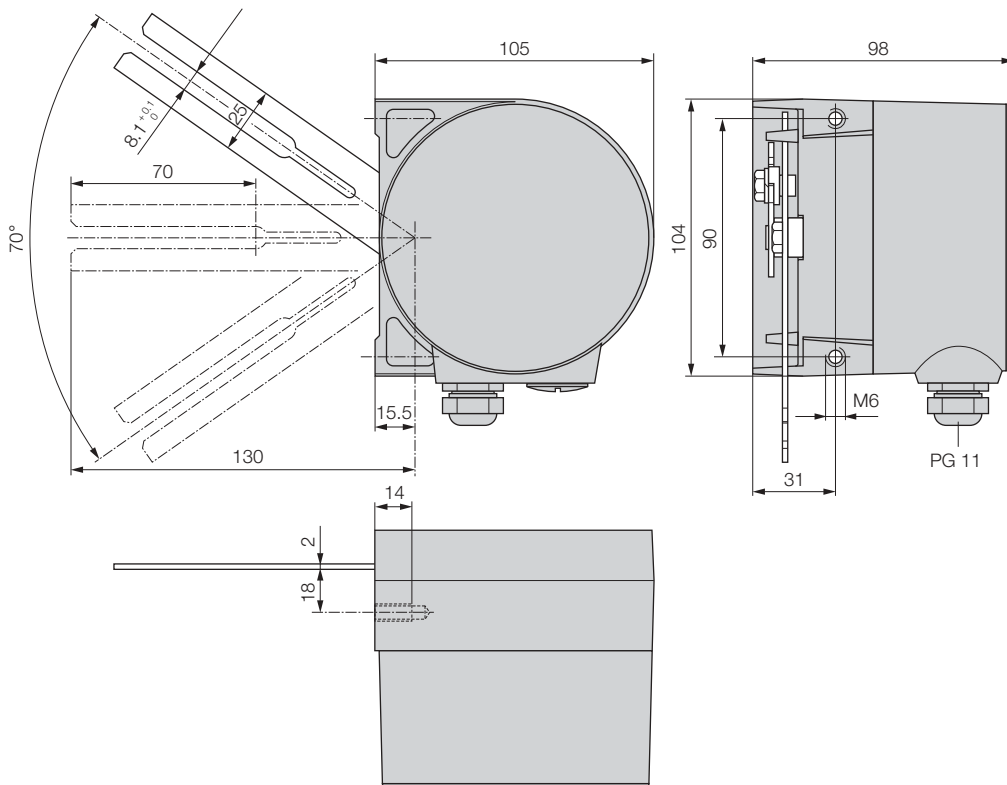

Fig. 10. Position of the KINAX SR 719 operating lever in the upper zero position, corresponding output current 4 mA.

KINAX SR 719

Programmable Transmitter for Position Feedback

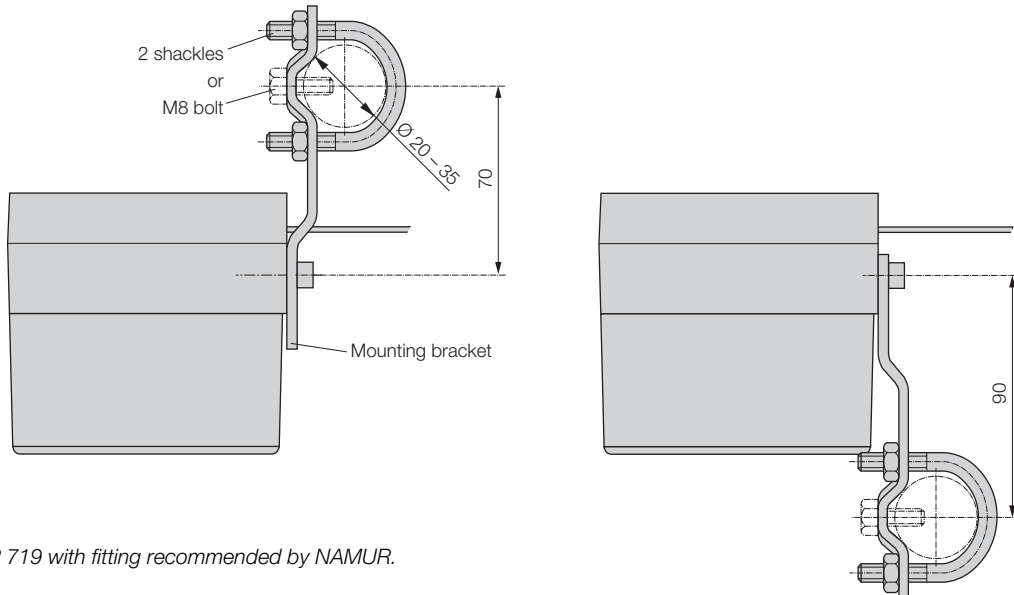

Fig. 11. KINAX SR 719 with fitting recommended by NAMUR.

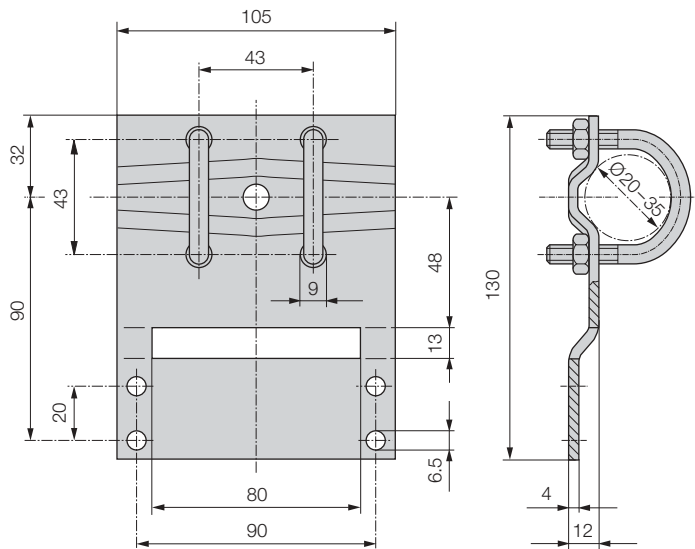

Fig. 12. NAMUR mounting set.

KINAX SR 719

Programmable Transmitter for Position Feedback

Printed in Switzerland • Subject to change without notice • Edition 07.03 • Data Sheet SR 719 Le

Camille Bauer Ltd
Aargauerstrasse 7
CH-5610 Wohlen/Switzerland
Phone +41 56 618 21 11
Fax +41 56 618 24 58
e-mail: info@camillebauer.com
<http://www.camillebauer.com>

 **CAMILLE BAUER**

 Member of
GMC Instruments Group