

# KINAX 3W2

## Transmitter for angular position

### Application

The **KINAX 3W2** (Figs. 1 to 3) converts the angular position of a shaft into a **load independent** direct current signal, proportional to the angular position. The unit is **contact free** and has **minimal mechanical abrasion** on the input shaft. It is a technically purposeful complement to the angle transmitter program. This compacter version is made possible by incorporating newly developed, highly integrated CMOS circuitry.

### Features / Benefits

- **Measuring input: Angular position**

Measured variable	Measuring range limits
Angular position	0...5° to 0...270°

- **Capacitive scanning system / Non mechanical abrasion, low annual maintenance**
- **Low influence from bearing play, < 0.1%**
- **Accuracy  $\leq 0.5\%$  for ranges  $\leq 150^\circ$**
- **Torque < 0.001 Ncm**
- **Drive shaft fully rotatable without stops**
- **For building into other equipment and as an OEM product / Very compact made only 48 mm in diameter**
- **Marine version also available as per Lloyd's Register of Shipping**
- **Available in type of protection "Intrinsic safety" EEx ia IIC T6 / Can be mounted within the hazardous area (see "Table 3: Data on explosion protection")**

### Layout and mode of operation

The transmitter consists of 2 main parts: the differential screen capacitor D and the electronic circuitry E (see Fig. 4).

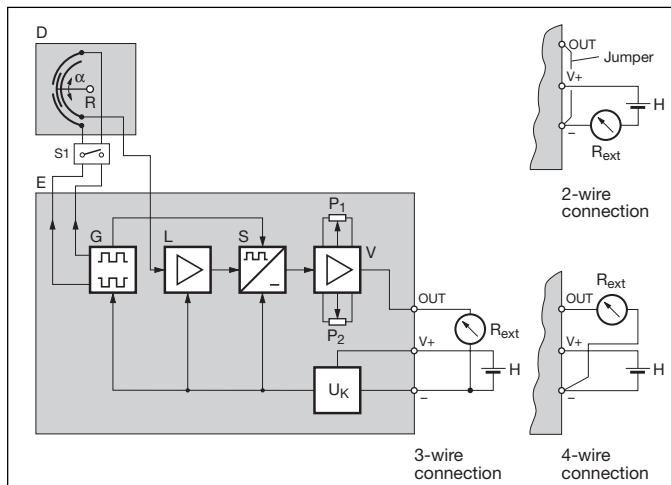

Fig. 1. KINAX 3W2 with shaft dia. 2 mm.



Fig. 2. KINAX 3W2 with shaft dia. 6 mm.



Fig. 3. Rear view with electrical connections and potentiometers for zero and FS.

Fig. 4. Block diagram.

S1 = Change-over switch sense of rotation for  $\alpha > 150^\circ$

# KINAX 3W2

## Transmitter for angular position

The angular deflection  $\alpha$  of the device to be measured is transferred to the rotor R of the differential screen capacitor with the aid of a mechanical coupling. It is then converted into a change of capacitance proportional to the angle.

The generator G produces 2 square voltages of 8 kHz shifted in phase by 180 degrees. These voltages are applied to the differential screen capacitor.

Any change in the rotor position results in a change of current at the charge amplifier input L. This current is amplified, rectified with the synchronous rectifier S, and passes to the output amplifier V, which converts it into a load-independent DC current.

The constant voltage source  $U_K$  supplies the circuit with a stable voltage which is independent of power supply fluctuations. Zero setting and end value can be adjusted with the potentiometers  $P_1$  and  $P_2$ .

Standard ranges:	0...1 mA, 3- or 4-wire connection 0...5 mA, 3- or 4-wire connection 0...10 mA, 3- or 4-wire connection 4...20 mA, 3- or 4-wire connection 4...20 mA, 2-wire connection or 0...20 mA, 3- or 4-wire connection adjustable with potentiometer
Non-standard ranges:	0...>1.00 to 0...< 20 mA 3- or 4-wire connection
External resistance (load):	$R_{\text{ext max.}} = \frac{\text{Power supply [V]} - 12 \text{ V}}{\text{Output signal end value [mA]}}$
Residual ripple in output current:	< 0.3% p.p.
Response time:	< 5 ms

### Accuracy

Reference value:	Measuring range
Basic accuracy:	Limit of error $\leq 0.5\%$ for ranges 0... $\leq 150^\circ$ Limit of error $\leq 1.5\%$ for ranges from 0...> 150° to 0...270°
Reproducibility:	< 0.2%

### Reference conditions

Ambient temperature	23 °C $\pm$ 2 K
Power supply	H = 18 V
External resistance	$R_{\text{ext}} = 0 \Omega$

### Influence effects (maxima) (included in basic error)

Linearity error	$\pm 0.4\%$ for ranges 0... $\leq 150^\circ$ $\pm 1.4\%$ for ranges from 0...> 150° to 0...270°
Dependence on external resistance $\Delta R_{\text{ext max.}}$	$\pm 0.1\%$
Power supply influence	$\pm 0.1\%$

### Additional errors (maxima)

Temperature influence (-25...+70 °C)	$\pm 0.2\%$ / 10 K
Bearing play influence	$\pm 0.1\%$

### Power supply H $\rightarrow \bigcirc$

DC voltage:	Version non intrinsically safe 12...33 V Version intrinsically safe 12...30 V max. residual ripple 10% p.p. (12 V must not be understepped) Protected against wrong polarity
-------------	--

## Technical data

### General

Measured quantity:	Angle of rotation $\alpha$ $\curvearrowright$ °
Measuring principle:	Capacitive method Differential screen capacitor with contact-free, non-wearing positional pick-up. Drive shaft fully rotatable without stops

### Measuring input $\rightarrow \bigcirc$

Standard measuring ranges of rotation angle $\alpha$ :	0...10°, 0...30°, 0...60°, 0...90°, 0...180°, 0...270°
Drive shaft diameters:	2 or 6 mm resp. 1/4"
Frictional torque:	< 0.001 Ncm with shaft dia. 2 mm < 0.03 Ncm with shaft dia. 6 mm resp. 1/4"
Sense of rotation as seen from the shaft side:	$\curvearrowright \leq 150^\circ$ possible in both senses of rotation (specify the required sense of rotation). $\curvearrowright > 150^\circ$ to $\leq 270^\circ$ , sense of rotation switchable with switch S1 (initial and end value must be readjusted)

### Measuring output $\bigcirc \rightarrow$

Output variable $I_A$ :	Load-independent DC current, proportional to the input angle
Zero point correction:	Approx. $\pm 5\%$
Span adjustment:	Approx. + 5 / - 30% see Feature 6
Current limitation:	$I_A$ max. 40 mA

## Installation data

Dimensions:	See section "Dimensional drawings"		
Housing:	Chromated aluminium		
Mounting position:	Any		
Electrical connections:	Soldering terminals Protection class IP 00 acc. to IEC 529		
Permissible vibrations:	5 g every 2 h in 3 directions $f \leq 200$ Hz		
Shock:	3x50 g 10 shocks each in 3 directions		
Admissible static loading of shaft:	Drive shafts dia.	2 mm	6 mm
	Sense		resp. 1/4"
	radial max.	16 N	83 N
	axial max.	25 N	130 N
Weight:	Approx. 100 g		
Fixation:	3 cheesehead screws M3 or with 3 clamps		

## Regulations

Electromagnetic compatibility:	The standards DIN EN 50 081-2 and DIN EN 50 082-2 are observed
--------------------------------	---

Intrinsically safe:	Acc. to EN 50 020: 1994
Impulse voltage withstand:	1 kV, 1.2/50 $\mu$ s, 0.5 Ws IEC 255-4, Cl. II
Housing protection:	IP 50 acc. to IEC 529
Test voltage:	All connections against housing 500 Veff., 50 Hz, 1 min.
Admissible common-mode voltage:	100 V, 50 Hz

## Environmental conditions

Climatic rating:	Standard version
	Temperature -25 to + 70 °C Annual mean relative humidity $\leq 90\%$ or Version with improved climatic rating Temperature -40 to + 70 °C Annual mean relative humidity $\leq 95\%$
Transportation and storage temperature:	Ex-version
	Temperature -40 to + 60 °C at T6 resp. -40 to + 75 °C at T5

## Table 1: Stock versions

The following transmitter versions are available ex stock. It is only necessary to quote the Order No.:

Order Code *)	Version	Sense of rotation	Measuring range (angle)	Output signal / power supply 12 ... 33 V DC	Order No.
708 - 112D	<b>Standard</b> (non intrinsically safe) with shaft dia. 2 mm, length 6 mm	Clockwise	0 ... 30°	<b>4 ... 20 mA</b> <b>2-wire connection</b> or 0...20 mA 3- or 4-wire connection (adjustable with potentiometer)	989 759
708 - 113D			0 ... 60°		993 213
708 - 114D			0 ... 90°		993 221
708 - 116D			0 ... 270°		993 239

\*) See section "Specifications and ordering information"

Instruments ex stock are factory set to output 4...20 mA for use in 2-wire connection.

When changing from 2- to 3- or 4-wire connection the initial and end values must be readjusted with P1 and P2 respectively.

The complete Order Code 708 - .... and/or a description according to the section "Specifications and ordering information" should be stated for other versions.

# KINAX 3W2

## Transmitter for angular position

**Table 2: Specification and ordering information**

Order Code 708 –			
Features, Selection	*SCODE	no-go	
<b>1. Version of the transmitter</b> (with standard shaft dia. 2 mm, at front <b>only</b> , length 6 mm*)			
1) Standard, Measuring output non intrinsically safe	A		1 . . . . .
2) EEx ia IIC T6 Measuring output intrinsically safe	B		2 . . . . .
5) Customized, Measuring output intrinsically safe	B	(Japan) (on request)	5 . . . . .
6) Ex ia IIC T6, Measuring output intrinsically safe	B	FTZU (Czech republic)	6 . . . . .
9) Other versions on request	B		9 . . . . .
<b>2. Sense of rotation</b>			
1) Calibrated for sense of rotation clockwise	D		. 1 . . . . .
2) Calibrated for sense of rotation counterclockwise	D		. 2 . . . . .
3) For "V" characteristic	E		. 3 . . . . .
4) Both senses of rotation, calibrated and marked	M		. 4 . . . . .
Lines 1 and 2: Angle ≤ 150° usable in both senses of rotation. Angle > 150° to ≤ 270° switchable to the other direction			
Line 4: For measuring ranges ≤ 90° only			
<b>3. Measuring range (measuring input) →</b>			
1) 0... 10 ↯ °		E	. . 1 . . . . .
2) 0... 30 ↯ °		E	. . 2 . . . . .
3) 0... 60 ↯ °		E	. . 3 . . . . .
4) 0... 90 ↯ °		E	. . 4 . . . . .
5) 0...180 ↯ °		EM	. . 5 . . . . .
6) 0...270 ↯ °		EM	. . 6 . . . . .
9) Non-standard 0... ≥ 5 to 0... < 270	[↯ °] <input type="text"/>	E	. . 9 . . . . .
A) "V" characteristic	[± ↯ °] <input type="text"/>	DM	. . A . . . . .
Line A: Specify start M <sub>A</sub> and end M <sub>E</sub> of measuring range! Observe the limits for (M <sub>A</sub> [± ↯ °] ≥ 10 and M <sub>E</sub> [± ↯ °] ≤ 150) and give both angles separated by an oblique stroke, e.g. [± ↯ °] 15 / 90!			
Example of a "V" characteristic for the measuring range [± ↯ °] 15 / 90 and an output range of 0...20 mA			

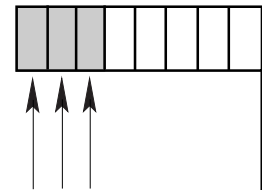

\* Possible deviations see Feature 7.

Order Code 708 –			
Features, Selection	*SCODE	no-go	
<b>4. Output signal</b> (measuring output) $\ominus \rightarrow$ / <b>Connecting version</b> Power supply (12...33 V DC resp. 12...30 V DC with <b>Ex</b> version)			
A) 0 ... 1 mA / 3- or 4-wire connection			A . . . . .
B) 0 ... 5 mA / 3- or 4-wire connection			B . . . . .
C) 0 ... 10 mA / 3- or 4-wire connection			C . . . . .
D) 4...20 mA / 2-wire connection or 0...20 mA / 3- or 4-wire connection (adjustable with potentiometer)			D . . . . .
E) 4 ... 20 mA / 3- or 4-wire connection			E . . . . .
Z) Non-standard, 3- or 4-wire connection 0...> 1.00 to 0...< 20 [mA] <input type="text"/>			Z . . . . .
R <sub>ext</sub> max. see section "Technical data", output signal			
<b>5. Special features</b>			
0) Without	Y		. 0 . . . . .
1) With			. 1 . . . . .
Without special features (line 0): Order code complete. With special feature (line 1): The features to be omitted must be marked hereafter with / (slant line) in the order code until reaching the required feature			
<b>6. Adjustability (span adjustment)</b>			
A) Increased adjustability + 5% / – 60 % Restriction: for angle $\geq 60^\circ$ , additional error 0.2 %		Y	. . A . . . . .
<b>7. Drive shaft special</b>			
C) Dia. 2 mm at front, length 12 mm, dia. 2 mm rear, length 6 mm		Y	. . . C . . . . .
D) Dia. 6 mm at front, length 12 mm		Y	. . . D . . . . .
E) Dia. 6 mm at front, length 12 mm, dia. 2 mm, length 6 mm		Y	. . . E . . . . .
F) Dia. 1/4", length 12 mm		Y	. . . F . . . . .
G) Dia. 1/4", length 12 mm, dia. 2 mm rear, length 6 mm		Y	. . . G . . . . .
<b>8. Improved climatic rating</b>			
H) Temperature –40 to + 70 °C, annual mean relative humidity $\leq 95\%$ instead of $\leq 90\%$ for the standard version		BY	. . . . H . . . .
J) With <b>Ex</b> version Temperature – 40 to + 60 °C at T6 resp. – 40 to + 75 °C at T5, annual mean relative humidity $\leq 95\%$		AY	. . . . J . . . .
<b>9. Marine version</b>			
L) Version GL ("Germanischer Lloyd")		Y	. . . . . L . . .

\* Lines with letter(s) under "no-go" cannot be combined with preceding lines having the same letter under "SCODE".

# KINAX 3W2

## Transmitter for angular position

**Table 3: Data on explosion protection**

Order Code	Type of protection "Intrinsically safe"		Certificates	Mounting location of device
	Instrument	Marking		
708 - 2 ...	EEx ia IIC T6	$U_i = 30 \text{ V}$ $I_i = 160 \text{ mA}$ $P_i = 1 \text{ W}$ $C_i \leq 10 \text{ nF}$ $L_i = 0$	Type Examination Certificate PTB 97 ATEX 2271	Within the hazardous area
708 - 5 ...	(Customized) on request		Japan	
708 - 6 ...	Ex ia IIC T6		Czech republic FTZU 98 Ex 0280	

### Electrical connections

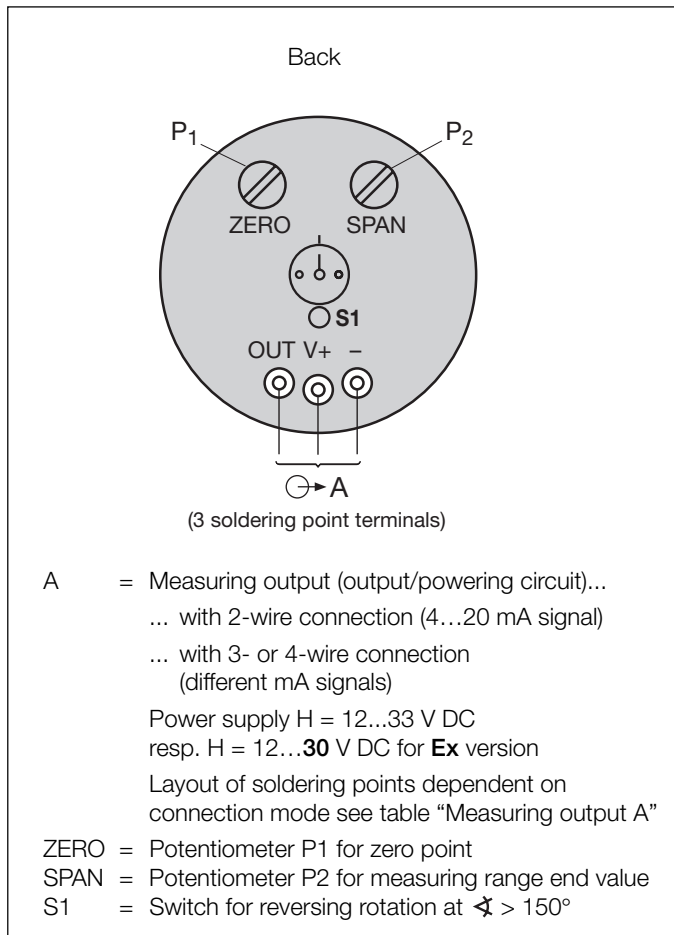

Measuring output A	
Connection mode	Terminal allocation
2-wire connection (4...20 mA)	
3-wire connection	
4-wire connection	

$R_{ext}$  = External resistance  
 H = Power supply  
 P<sub>1</sub>, Potentiometer for zero point  
 P<sub>2</sub>, Potentiometer for measuring range end value

When changing from 2- to 3- or 4-wire connection the initial and end values must be readjusted with P1 and P2 respectively.

## Dimensional drawings

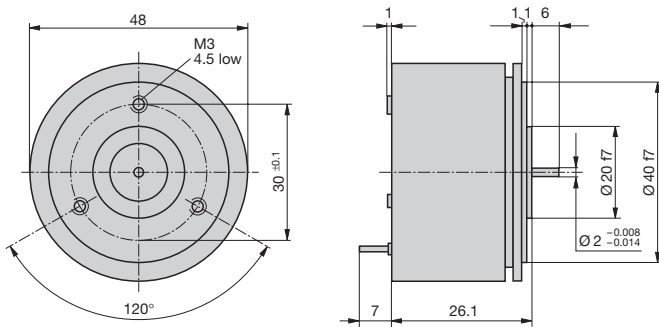

Fig. 5. KINAX 3W2 with shaft dia. 2 mm, length 6 mm, standard version.

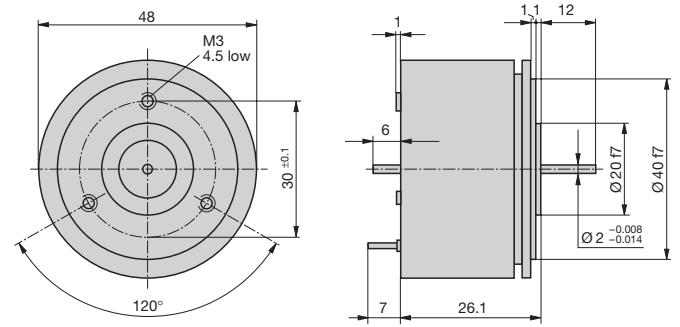

Fig. 6. KINAX 3W2 with shaft dia. 2 mm at front, length 12 mm, dia. 2 mm rear, length 6 mm.

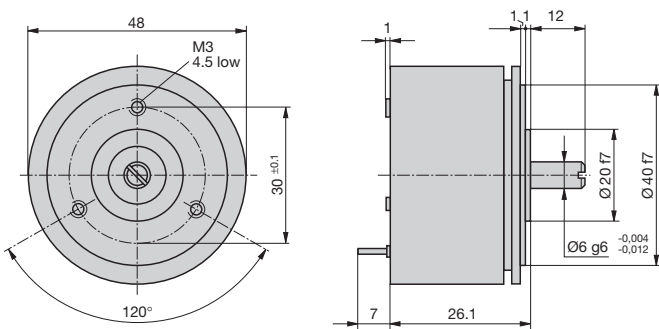

Fig. 7. KINAX 3W2 with shaft dia. 6 mm, length 12 mm.

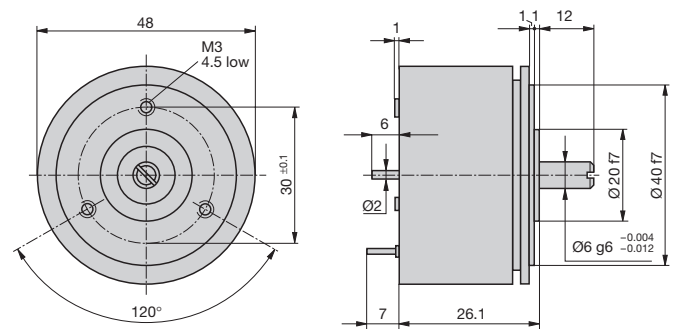

Fig. 8. KINAX 3W2 with shaft dia. 6 mm at front, length 12 mm, dia. 2 mm rear, length 6 mm.

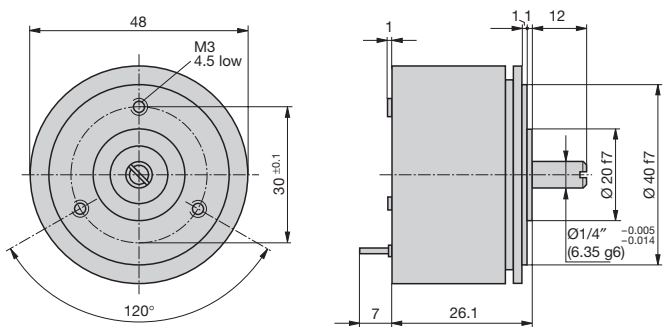

Fig. 9. KINAX 3W2 with shaft dia. 1/4", length 12 mm.

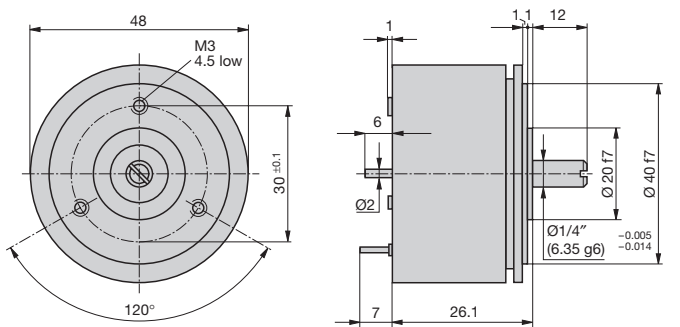

Fig. 10. KINAX 3W2 with shaft dia. 1/4", length 12 mm, dia. 2 mm rear, length 6 mm.

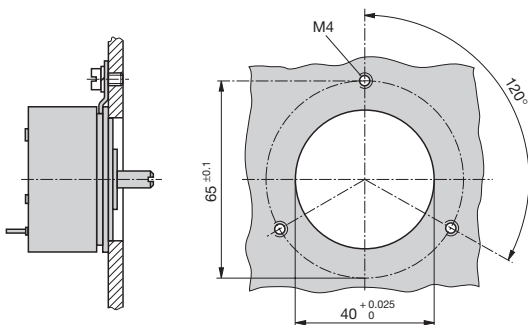

Fig. 11. Drilling plan for fixing with 3 spring clamps.

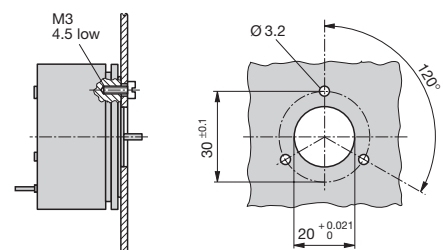

Fig. 12. Drilling plan for fixing with 3 cheesehead screws M3.

# **KINAX 3W2**

## **Transmitter for angular position**

---

### **Standard accessories**

- 3 clamps
- 1 Operating Instructions each in German, French and English
- 1 Ex approval (for instruments in Ex version only)

**MOD-TRONIC**  
INSTRUMENTS LIMITED

48 Haggert Ave N  
Brampton, ON L6X 1Y3  
Tel: 905 457-6322  
Fax: 905 457-4716  
Toll Free: 800 794-5883