

SINEAX G 536

Phase angle or power factor transducer

Carrying rail housing P13/70

Application

The transducer **SINEAX G 536** (Fig. 1) measures the phase angle or power factor between current and voltage of a single or 3-phase balanced network having a sine wave form.

The output signal, in the form of a **load independent** DC current or voltage, is proportional to the phase angle resp. power factor between the 2 measured quantities current and voltage.

The transducer fulfils all the important requirements and regulations concerning electromagnetic compatibility **EMV** and **Safety** (IEC 1010 resp. EN 61 010). It was developed and is manufactured and tested in strict accordance with the **quality assurance standard** ISO 9001.

Features / Benefits

- **Measuring input:** Sine, rectangular or distorted wave forms of input quantities with dominant fundamental waves

Measured variables	Nominal input current	Nominal input voltage	Measuring range limits
Phase angle or power factor	0.5 to 6 A	10 to 690 V	Min. span 20 °el Max. span 360 °el

- **Measuring output:** Unipolar, bipolar or live zero output variables
- **Measuring principle:** Measurement of the zero crossing interval
- **AC/DC power supply / Universal**
- **Standard as marine version per Lloyd's Register of Shipping**

Table 1: Standard versions for power factor

Nominal input frequency: 50 Hz
 Measuring range (incoming): 0.5 ... cap ... 1 ... ind ... 0.5 cosφ
 Output: Proportional cosφ
 Power supply: 85 ... 230 V/DC or 40 ... 400 Hz

The following transducer versions are available as standard versions. It is only necessary to quote the **Order No.:**

Inputs	Application	Output signal	Response time Periods of the input frequency	Order No.
230 V/L & N and 5 A/L	Single-phase AC	0...20 mA	4	127 094
		4...20 mA		126 830
400 V/L1&L2 and 5 A/L1	3 or 4-wire 3-phase balanced load	0...20 mA		127 101
		4...20 mA		126 848

Please complete the Order Code 536-4... .. acc. to "Table 3: Specification and Ordering Information" for other versions.



Fig. 1. Transducer SINEAX G 536 in housing P13/70 clipped onto a top-hat rail.

Technical data

General

Measured quantity: Phase angle or power factor between current and voltage

Measuring principle: Measurement of the zero crossing interval

Measuring input

Examples of measuring ranges with φ-linear output

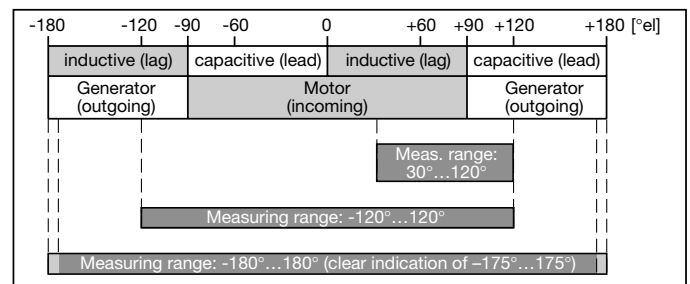

Examples of measuring ranges with cosφ-linear output

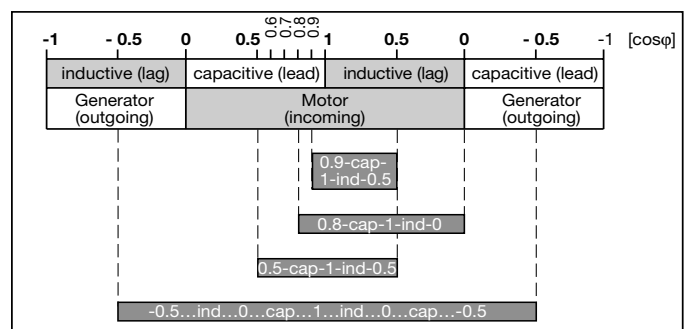

Nominal frequency f_N : 16 2/3 ... 400 Hz
 Nominal input voltage U_N : 10 ... 690 V
 (max. 230 V with power supply from voltage measuring input)
 Response sensitivity: 10 ... 120% U_N

SINEAX G 536

Phase angle or power factor transducer

Nominal input current I_N : ≥ 0.5 to 6.0 A
 Response sensitivity: $< 1\%$ I_N
 Own consumption: < 0.1 VA per current path
 $U_N \cdot 1.5$ mA per voltage path
 Overload capacity:

Input variables I_N, U_N	Number of applications	Duration of one application	Interval between two successive applications
$1.2 \times I_N$	---	continuously	---
$20 \times I_N$	10	1 s	100 s
$1.2 \times U_N^1$	---	continuously	---
$2 \times U_N^1$	10	1 s	10 s

¹ But max. 264 V with power supply from voltage measurement

Measuring output \rightarrow

Load-independent DC current: 0 ... 1 to 0 ... 20 mA
 resp. live-zero
 1 ... 5 to 4 ... 20 mA
 ± 1 to ± 20 mA

Burden voltage: + 15 V, resp. - 12 V

Load-independent DC voltage: 0 ... 1 to 0 ... 10 V
 resp. live-zero
 0.2 ... 1 to 2 ... 10 V
 ± 1 to ± 10 V

Load capacity: Max. 4 mA

Voltage limit under $R_{ext} = \infty$: ≤ 25 V

Current limit under overload: Approx. 30 mA

Residual ripple in output current: $< 0.5\%$ p.p.

Nominal value of response time: 4 periods of the nominal frequency

Other ranges: 2, 8 or 16 periods of the nominal frequency

Output characteristic

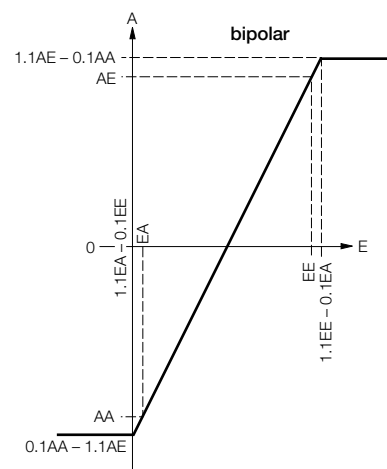
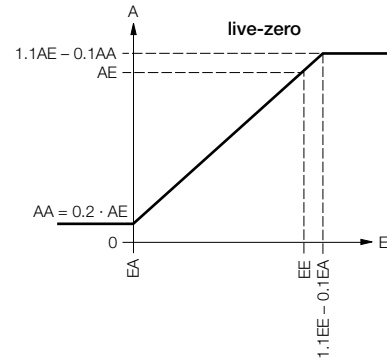
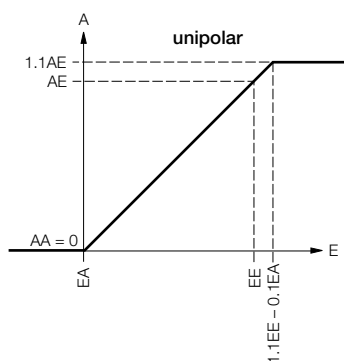

E = Input
 EA = Input start value
 EE = Input end value
 A = Output
 AA = Output start value
 AE = Output end value

Accuracy (acc. to DIN/IEC 688)

Reference value: $\Delta\phi = 90^\circ$ resp. $\Delta \cos\phi = 0.5$
 Basic accuracy: Class 0.5

Reference conditions:

Ambient temperature: 15 ... 30 °C
 Input current: 0.8 ... 1.2 I_N
 Input voltage: 0.8 ... 1.2 U_N
 Frequency: $f_N \pm 10\%$
 Wave forms: Sine wave
 Power supply: At nominal range
 Output burden: ΔR_{ext} max.

Additional errors (maxima):

Voltage influence between 0.5 and 1.5 U_N : $\pm 0.3\%$
 Current influence
 - between 0.4 and 1.5 I_N : $\pm 0.3\%$
 - between 0.1 and 1.5 I_N : $\pm 0.5\%$

Safety

Protection class:	II (protection isolated, DIN EN 61 010)
Housing protection:	IP 40, housing (test wire, EN 60 529) IP 20, terminals (test finger, EN 60 529)
Contamination level:	2
Overvoltage category:	III
Rated insulation voltage (against earth):	230 V resp. 400 V, inputs 230 V, power supply 40 V, output
Test voltage:	50 Hz, 1 min. acc. to DIN EN 61 010-1 3700 resp. 5550 V, inputs versus all other circuits as well as outer surface 3250 V, input circuits versus each other 3700 V, power supply versus output as well as outer surface 490 V, output versus outer surface

Power supply →○

AC/DC power pack (DC or 40 ... 400 Hz)

Table 2: Rated voltages and permissible variations

Rated voltage	Tolerance
85 ... 230 V DC / AC	DC - 15 ... + 33% AC ± 15%
24 ... 60 V DC / AC	
or	

Power supply from voltage measuring input:	24 ... 60 V AC or 85 ... 230 V AC
Option:	Connect to the low tension to termi- nals 12 and 13 24 V AC or 24 ... 60 V DC
Power consumption	Approx. 2 W resp. 4 VA

Installation data

Mechanical design: Housing **P13/70**

Material of housing:	Lexan 940 (polycarbonate), flammability Class V-0 acc. to UL 94, self-extinguishing, non-dripping, free of halogen
Mounting:	For rail mounting
Mounting position:	Any
Weight:	Approx. 0.24 kg

Connecting terminals

Connection element:	Screw-type terminals with indirect wire pressure
Permissible cross section of the connection leads:	≤ 4.0 mm ² single wire or 2 × 2.5 mm ² fine wire

Environmental conditions

Climatic rating:	Climate class 3 acc. to VDI/VDE 3540
Operating temperature:	- 10 to +55 °C
Storage temperature:	- 40 to +70 °C
Relative humidity of annual mean:	≤ 75%

Vibration withstand

(tested according to DIN EN 60 068-2-6)

Acceleration:	± 2 g
Frequency range:	10 ... 150 ... 10 Hz, rate of frequency sweep: 1 octave / minute
Number of cycles:	10 in each of the three axes
Result:	No faults occurred, no loss of accu- racy and no problems with the snap fastener

Germanischer Lloyd

Type approval certificate:	No. 12 261-98 HH
Ambient category:	C
Vibration:	0.7 g

Table 3: Specification and ordering information (see also Table 1: Standard versions)

Order Code 536 -			
Features, Selection	*SCODE	no-go	
1. Mechanical design 4) Housing P13/70 for rail mounting			
2. Measuring mode 1) For phase angle (φ -linear) 2) For power factor ($\cos\varphi$ -linear)	A B		

SINEAX G 536

Phase angle or power factor transducer

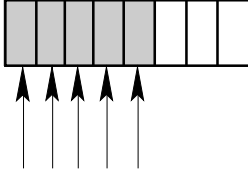
Order Code 536 -	*SCODE	no-go	
Features, Selection			
3. Application 1) Single-phase AC 2) U: L1 & L2 I: L1 3 or 4-wire 3-phase balanced load 3) U: L2 & L3 I: L2 3 or 4-wire 3-phase balanced load 4) U: L3 & L1 I: L3 3 or 4-wire 3-phase balanced load 5) U: L1 & L3 I: L1 3 or 4-wire 3-phase balanced load 6) U: L2 & L1 I: L2 3 or 4-wire 3-phase balanced load 7) U: L3 & L2 I: L3 3 or 4-wire 3-phase balanced load A) U: L1 & L2 I: L3 3 or 4-wire 3-phase balanced load B) U: L2 & L3 I: L1 3 or 4-wire 3-phase balanced load C) U: L3 & L1 I: L2 3 or 4-wire 3-phase balanced load			1 2 3 4 5 6 7 A B C
4. Nominal input frequency 1) 50 Hz 2) 60 Hz 9) Non-standard [Hz] <input type="text"/> ≥ 10 to 400 Hz With power supply from measuring input min. 40 Hz			. 1 2 9
5. Nominal input voltage 1) $U_N = 100$ V 2) $U_N = 230$ V 3) $U_N = 400$ V 9) Non-standard [V] <input type="text"/> ≥ 10 to 690 With power supply from measuring input min. 24 V, max. 230 V, see feature 9, lines 3 and 4 3-phase system: Input voltage = phase to phase voltage	C C D		. . 1 2 3 9
6. Nominal input current 1) 1 A 2) 5 A 9) Non-standard [A] <input type="text"/> ≥ 0.5 to 6.0			. . . 1 2 9
7. Measuring range 1) Phase angle $-60 \dots 0 \dots +60$ °el 2) $\cos\phi$ 0.5 ... cap ... 1 ... ind ... 0.5 9) Non-standard [°el] or [$\cos\phi$] <input type="text"/> Measuring range within $-180 \dots 0 \dots +180$ °el or $-1 \dots \text{ind} \dots 0 \dots \text{cap} \dots 1 \dots \text{ind} \dots 0 \dots \text{cap} \dots -1$, but clear indication only to $-175 \dots 0 \dots +175$ °el Measuring span ≥ 20 °el		B A 1 2 9

SINEAX G 536

Phase angle or power factor transducer

Electrical connections

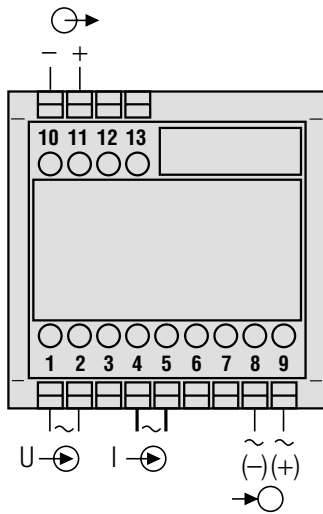

Fig. 2. Power supply connected to terminals 8 and 9.

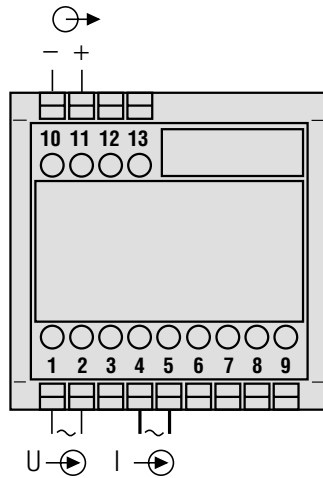

Fig. 3. Power supply internal from measuring input, without separated power supply.

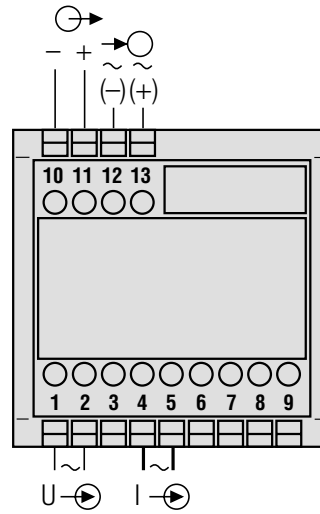



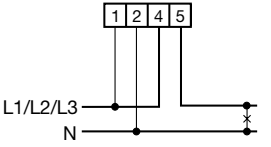
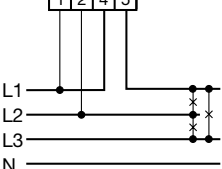
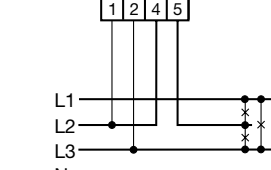
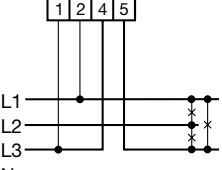
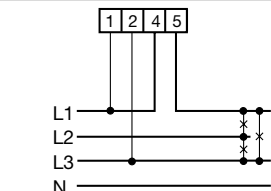
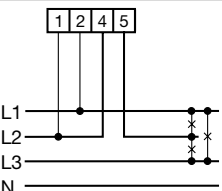
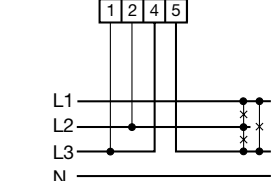
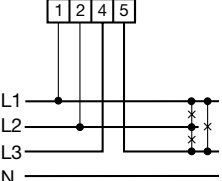
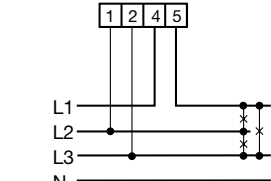
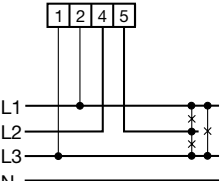
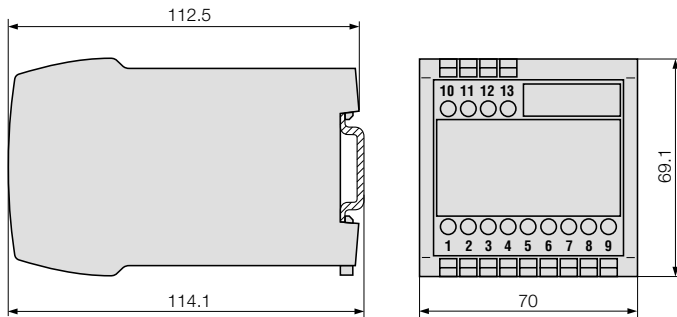

Fig. 4. Power supply connected to the low tension terminal side 12 and 13.

 = Meas. input
 = Meas. output
 = Power supply

Measuring inputs			
Application	Terminal allocation	Application	Terminal allocation
Phase angle or power factor measurement in single-phase AC network		Phase angle or power factor measurement in 3 or 4-wire 3-phase network U: L1 & L2 I: L1	
Phase angle or power factor measurement in 3 or 4-wire 3-phase network U: L2 & L3 I: L2		Phase angle or power factor measurement in 3 or 4-wire 3-phase network U: L3 & L1 I: L3	
Phase angle or power factor measurement in 3 or 4-wire 3-phase network U: L1 & L3 I: L1		Phase angle or power factor measurement in 3 or 4-wire 3-phase network U: L2 & L1 I: L2	
Phase angle or power factor measurement in 3 or 4-wire 3-phase network U: L3 & L2 I: L3		Phase angle or power factor measurement in 3 or 4-wire 3-phase network U: L3 & L1 I: L2	
Phase angle or power factor measurement in 3 or 4-wire 3-phase network U: L2 & L3 I: L1		Phase angle or power factor measurement in 3 or 4-wire 3-phase network U: L3 & L1 I: L2	

Dimensional drawing



Standard accessories

1 Operating Instructions in three languages: German, French, English

Fig. 5. Housing **P13/70** clipped onto a top-hat rail (35 × 15 mm or 35 × 7.5 mm, acc. to EN 50 022).

SINEAX G 536

Phase angle or power factor transducer

Printed in Switzerland • Subject to change without notice • Edition 06.99 • Data sheet No. G 536 Le

MOD-TRONIC
INSTRUMENTS LIMITED

48 Haggert Ave N
Brampton, ON L6X 1Y3
Tel: 905 457-6322
Fax: 905 457-4716
Toll Free: 800 794-5883