

# SINEAX I 538

## Transducer for AC current

With power supply  
Carrying rail housing P8/35



### Application

The transducer **SINEAX I 538** (Fig. 1) converts a sinusoidal AC current into a **load independent** DC current or a **load independent** DC voltage proportional to the measured value.

The transducer fulfils all the important requirements and regulations concerning electromagnetic compatibility **EMC** and **Safety** (IEC 1010 resp. EN 61 010). It was developed and is manufactured and tested in strict accordance with the **quality assurance standard** ISO 9001.

### Features

- **Measuring input: AC current, sine wave forms**

Measured variable	Measuring range limits
AC current	0 ... 0.8 to 0 ... 1.2 A or 0 ... 4 to 0 ... 6 A

- **Measuring output: Unipolar and live zero output variables**
- **Also available with output signal 4...20 mA in 2-wire connection**
- **Measuring principle: Rectifier method**
- **Standard as marine version per Lloyd's Register of Shipping**

### Table 1: Standard versions

The following transducer versions are available as standard versions. It is only necessary to quote the **Order No.:**

Nominal frequency	Measuring range	Output signal	Power supply	Order No.
50/60 Hz	0 ... 1 A	0 ... 20 mA	230 V AC 4-wire connection	136 516
	0 ... 5 A		24 V DC 4-wire connection	136 524
	0 ... 1 A		24 V DC 4-wire connection	136 558
	0 ... 5 A		24 V DC 4-wire connection	136 566
	0 ... 1 A	4 ... 20 mA	230 V AC 4-wire connection	137 431
	0 ... 5 A		24 V DC 4-wire connection	137 449
	0 ... 1 A		24 V DC 2-wire connection	136 590
	0 ... 5 A		24 V DC 2-wire connection	136 607

Please complete the Order Code 538-41... according to Table 2: "Specification and Ordering Information" for versions with user-specific input and/or output ranges.

### Technical data

#### Measuring input E

Nominal frequency  $f_N$ : 50 / 60 Hz  
 Nominal input current  $I_N$   
 (measuring range end value): Measuring range limit values  
 0 ... 0.8 to 0 ... 1.2 A  
 or  
 0 ... 4 to 0 ... 6 A



Fig. 1. Transducer SINEAX I 538 in housing P8/35 clipped onto a top-hat rail.

Own consumption:  $\leq 5 \text{ mV} \cdot I_N$  with input end value

Overload capacity:

Measured quantity $I_N$	Number of applications	Duration of one application	Interval between two successive applications
$1.2 \cdot I_N$	---	continuously	---
$20 \cdot I_N$	10	1 s	100 s

#### Measuring output A

Load-independent DC current: 0 ... 1.0 to 0 ... 20 mA resp. live zero 0.2 ... 1 to 4 ... 20 mA

Burden voltage: 15 V

External resistance:  $R_{\text{ext max.}} [\text{k}\Omega] \leq \frac{15 \text{ V}}{I_{\text{AN}} [\text{mA}]}$

$I_{\text{AN}}$  = Output current end value

#### With 2-wire connection

Standard ranges 4 ... 20 mA  
 External resistance  $R_{\text{ext}}$ , dependent on power supply H (12 ... 32 V DC)

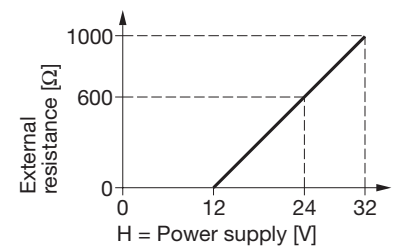

$$R_{\text{ext max.}} [\text{k}\Omega] = \frac{H [\text{V}] - 12 \text{ V}}{20 \text{ mA}}$$

Load-independent DC voltage: 0 ... 1 to 0 ... 10 V resp. live zero 0.2 ... 1 to 2 ... 10 V

# SINEAX I 538

## Transducer for AC current

External resistance:	$R_{\text{ext}} \text{ min. [k}\Omega\text{]} \geq \frac{U_A \text{ [M]}}{10 \text{ mA}}$
Residual ripple in output current:	< 30 mA
Voltage limit under $R_{\text{ext}} = \infty$ :	< 40 V
Residual ripple in output current:	$\leq 1\%$ p.p.
Setting time:	< 300 ms
<b>Power supply H</b> 	
AC voltage:	24, 110, 115, 120, 230 or 400 V, $\pm 15\%$ , 50 / 60 Hz Power consumption approx. 3 VA
DC voltage:	24 V – 15 / + 33%, Power consumption approx. 1.5 W or 24 V, – 50 / + 33% at 2-wire connection and output 4...20 mA
DC or AC voltage:	DC, AC power pack (DC or 40 - 400 Hz) 85 - 230 V or 24 - 60 V DC – 15/+ 33%, AC $\pm 15\%$ Power consumption $\leq 1.5$ W resp. $\leq 3$ VA

### Accuracy (acc. to EN 60 688)

Reference value:	Output end value
Accuracy:	Class 0.5

### Reference conditions:

Ambient temperature	15 ... 30 °C
Input frequency	50 Hz
Curve shape	Sine-wave, Distortion factor < 1%
Output burden	Current: $0.5 \cdot R_{\text{ext}} \text{ max.}$ Voltage: $2 \cdot R_{\text{ext}} \text{ min.}$
Power supply	In rated range

### Safety

Protection class:	II (protection isolated, EN 61 010)
Housing protection:	IP 40, housing (test wire, EN 60 529) IP 20, terminals (test finger, EN 60 529)
Contamination level:	2
Overvoltage category:	III
Rated insulation voltage (versus earth):	300 V input 300 V power supply AC 50 V power supply 24 V DC 50 V output

Test voltage:	50 Hz, 1 min. acc. to EN 61 010-1 3700 V, input versus all other circuits as well as outer surface 3700 V, power supply AC versus output as well as outer surface 490 V, power supply 24 V DC versus output as well as outer surface 490 V, output versus outer surface
---------------	---

### Installation data

Mechanical design:	Housing <b>P8/35</b>
Material of housing:	Lexan 940 (polycarbonate), flammability Class V-0 acc. to UL 94, self-extinguishing, non-dripping, free of halogen
Mounting:	For rail mounting
Weight:	Approx. 280 g with AC power supply Approx. 210 g with DC power supply Approx. 125 g with 2-wire connection Approx. 220 g with DC, AC power pack

### Connecting terminals

Connection element:	Screw-type terminals with indirect wire pressure
Permissible cross section of the connection leads:	4.0 mm <sup>2</sup> single wire or 2 × 2.5 mm <sup>2</sup> fine wire

### Environmental conditions

Operating temperature:	– 10 to + 55 °C
Storage temperature:	– 40 to + 70 °C
Relative humidity of annual mean:	$\leq 75\%$

### Ambient tests

EN 60 068-2-6:	Vibration
Acceleration:	$\pm 2$ g
Frequency range:	10 ... 150 ... 10 Hz, rate of frequency sweep: 1 octave/minute
Number of cycles:	10, in each of the three axes
EN 60 068-2-27:	Shock
Acceleration:	3 × 50 g 3 shocks each in 6 directions
EN 60 068-2-1/-2/-3:	Cold, dry heat, damp heat
IEC 1000-4-2/-3/-4/-5/-6 EN 55 011:	Electromagnetic compatibility

### Germanischer Lloyd

Type approval certificate:	No. 12 258-98 HH
Ambient category:	C
Vibration:	0.7 g

**Table 2: Specification and ordering information** (see also Table 1: Standard versions)

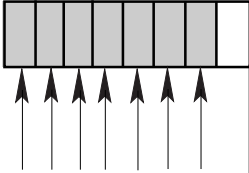
Order Code <b>538</b> -				
Features, Selection	*SCODE	no-go		
<b>1. Mechanical design</b> 4) Housing P8/35 for rail mounting			4	.
<b>2. Nominal input frequency</b> 1) 50 / 60 Hz			.	1
<b>3. Measuring range</b> A) 0 ... 1 A B) 0 ... 5 A Z) Non-standard [A] <input type="text"/> 0 ... 0.8 to 0 ... 1.2 or 0 ... 4 to 0 ... 6			.	A
			.	B
			.	Z
<b>4. Output signal</b> 1) 0 ... 20 mA, $R_{ext} \leq 750 \Omega$ 2) 4 ... 20 mA, $R_{ext} \leq 750 \Omega$ 3) 4 ... 20 mA, 2-wire connection, $R_{ext}$ dependent on power supply 9) Non-standard [mA] <input type="text"/> 0 ... 1 to 0 ... < 20 0.2 ... 1 to < (4 ... 20) A) 0 ... 10 V, $R_{ext} \geq 1 k\Omega$ Z) Non-standard [M] <input type="text"/> 0 ... 1.00 to 0 ... < 10 0.2 ... 1 to 2 ... 10	A		.	1
	A		.	2
	B		.	3
	A		.	9
	A		.	A
	A		.	Z
<b>5. Power supply</b> 1) 24 V, 50/60 Hz 2) 110 V, 50/60 Hz 3) 115 V, 50/60 Hz 4) 120 V, 50/60 Hz 5) 230 V, 50/60 Hz 6) 400 V, 50/60 Hz, max. 300 V versus earth A) 24 V DC B) 24 V DC via output circuit at 2-wire connection C) 24 ... 60 V DC, AC (DC, AC power pack) D) 85 ... 230 V DC, AC (DC, AC power pack)	C	B	.	1
	C	B	.	2
	C	B	.	3
	C	B	.	4
	C	B	.	5
	C	B	.	6
	C	B	.	A
	C	A	.	B
		B	.	C
		B	.	D
<b>6. Measuring range adjustable</b> 0) Measuring range end value permanently set (standard) 1) Measuring range can be adjusted approx. $\pm 10\%$ Line 1: Only in combination with DC, AC power pack, feature 5, line C or D!			.	0
		C	.	1
<b>7. Test certificate</b> 0) Without test certificate D) Test certificate in German E) Test certificate in English			.	0
			.	D
			.	E

\* Lines with letter(s) under "no-go" cannot be combined with preceding lines having the same letter under "SCODE".

# SINEAX I 538

## Transducer for AC current

### Electrical connections

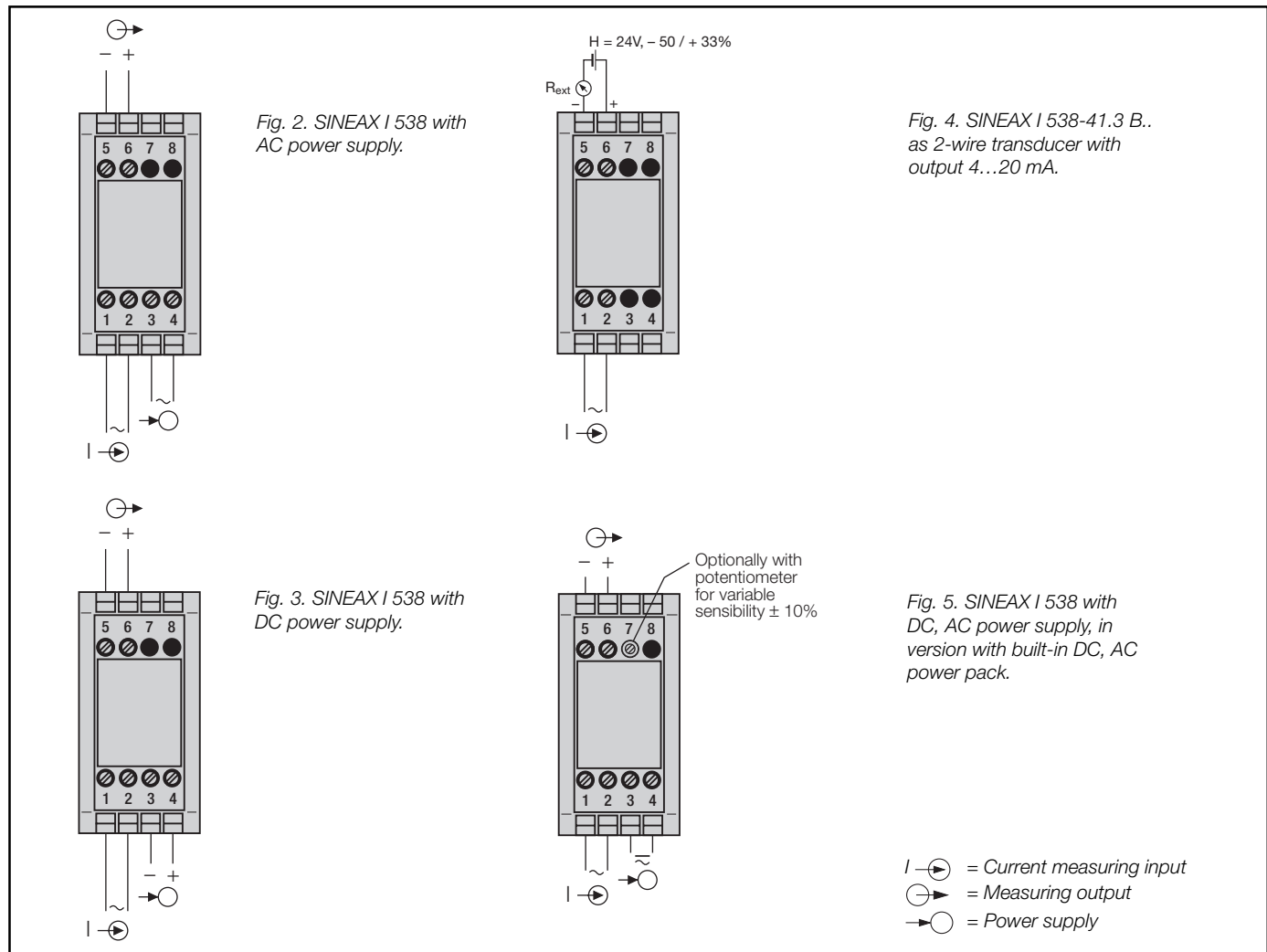

### Dimensional drawing

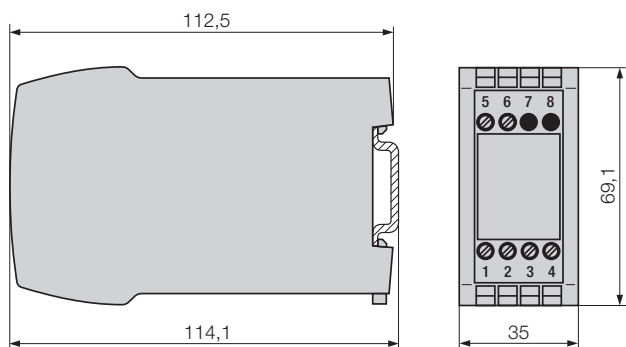

Fig. 6. SINEAX I 538 in housing **P8/35** clipped onto a top-hat rail (35 x 15 mm or 35 x 7.5 mm, acc. to EN 50 022).

### Standard accessories

1 Operating Instructions in three languages: German, French, English