

SINEAX M 563 with 3 analogue outputs

Programmable multi-transducer for industry

for the measurement of electrical variables in heavy-current power system



Application

SINEAX M 563 (Fig. 1) is a programmable transducer with a **RS 232 C interface**. It supervises any 3 variables of an electrical power system **simultaneously** and generates 3 electrically insulated analogue output signals.

The transducers are also equipped with an **RS 232** serial interface to which a PC with the corresponding software can be connected for programming or accessing and executing useful ancillary functions.

The usual methods of connection, the types of measured variables, their ratings, the transfer characteristic for each output etc. are the main parameters that can be programmed.

The ancillary functions include displaying, recording and evaluation of measurements on a PC, the simulation of the outputs for test purposes and a facility for printing nameplates.

The transducer fulfils all the essential requirements and regulations concerning electromagnetic compatibility (**EMC**) and **safety** (IEC 1010 resp. EN 61 010). It was developed and is manufactured and tested in strict accordance with the **quality assurance standard ISO 9001**.

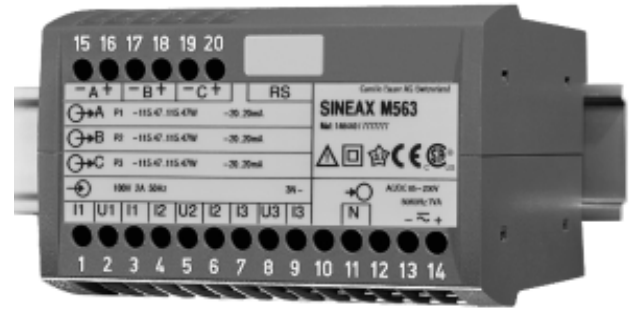

Fig. 1. SINEAX M 563 transducer in housing P20/105 clipped onto a top-hat rail.

Features / Benefits

- Simultaneous measurement of several variables of a heavy-current power system

| Measured variables | Nominal input current | Nominal input voltage |
|--|-----------------------|---|
| Current, voltage (rms), active/reactive/apparent power $\cos\phi$, $\sin\phi$, power factor RMS value of the current with wire setting range (bimetal measuring function) Slave pointer function for the measurement of the RMS value IB Frequency Average value of the currents with sign of the active power (power system only) | 1 to 6 A | 57.7 to 400 V (phase-to-neutral) resp. 100 to 693 V (phase-to-phase) |

- For all heavy-current power system variables
- Universal analogue outputs (programmable)
- Input voltage up to 693 V (phase-to-phase)
- High accuracy: Class 0.5 (under reference conditions)
- Windows software with password protection for programming, data analysis, power system status simulation
- DC-, AC-power pack with wide power supply tolerance / Universal

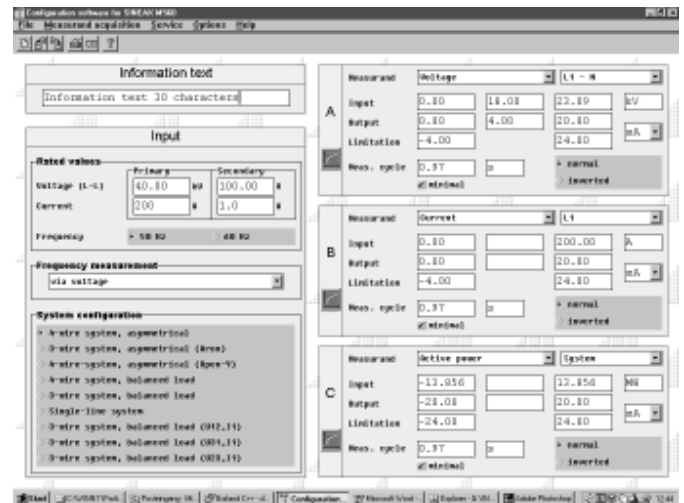
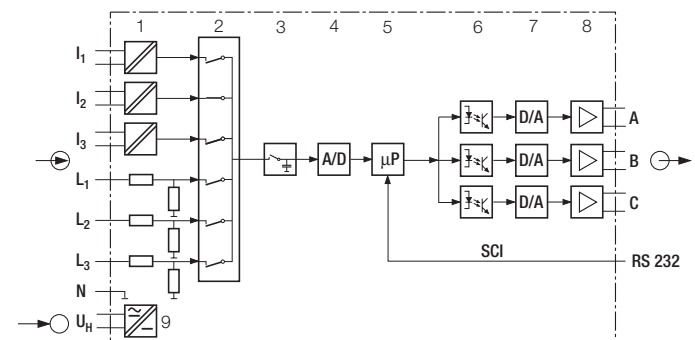

Fig. 2. Screen print-out from the configuration software.



- 1 = Input transformer (I1, I2, I3)
- 1 = Voltage divider (L1, L2, L3)
- 2 = Multiplexer
- 3 = Latching stage
- 4 = A/D converter
- 5 = Microcontroller
- 6 = Electrical insulation
- 7 = D/A converter
- 8 = Output stage
- 9 = DC, AC power pack

Fig. 3. Block diagram.

SINEAX M 563 with 3 analogue outputs

Programmable multi-transducer for industry

Symbols

| Symbols | Meaning | Symbols | Meaning (Continuation) |
|---------|--|---------|---|
| X | Measured variable | Q | Reactive power of the system $Q = Q1 + Q2 + Q3$ |
| X0 | Lower limit of the measured variable | Q1 | Reactive power phase 1 (phase-to-neutral L1 – N) |
| X1 | Break point of the measured variable | Q2 | Reactive power phase 2 (phase-to-neutral L2 – N) |
| X2 | Upper limit of the measured variable | Q3 | Reactive power phase 3 (phase-to-neutral L3 – N) |
| Y | Output variable | S | Apparent power of the system |
| Y0 | Lower limit of the output variable | S1 | Apparent power phase 1 (phase-to-neutral L1 – N) |
| Y1 | Break point of the output variable | S2 | Apparent power phase 2 (phase-to-neutral L2 – N) |
| Y2 | Upper limit of the output variable | S3 | Apparent power phase 3 (phase-to-neutral L3 – N) |
| Y2 SW | Programmed upper limit of the output variable | Sr | Rated value of the apparent power of the system |
| U | Input voltage | PF | Active power factor $\cos\phi = P/S$ |
| Ur | Rated value of the input voltage | PF1 | Active power factor phase 1 P1/S1 |
| U 12 | Phase-to-phase voltage L1 – L2 | PF2 | Active power factor phase 2 P2/S2 |
| U 23 | Phase-to-phase voltage L2 – L3 | PF3 | Active power factor phase 3 P3/S3 |
| U 31 | Phase-to-phase voltage L3 – L1 | QF | Reactive power factor $\sin\phi = Q/S$ |
| U1N | Phase-to-neutral voltage L1 – N | QF1 | Reactive power factor 1 Q1/S1 |
| U2N | Phase-to-neutral voltage L2 – N | QF2 | Reactive power factor 2 Q2/S2 |
| U3N | Phase-to-neutral voltage L3 – N | QF3 | Reactive power factor 3 Q3/S3 |
| I | Input current | LF | Power factor of the system $LF = \text{sgn}Q \cdot (1 - PF)$ |
| I1 | AC current L1 | LF1 | Power factor phase 1 $\text{sgn}Q1 \cdot (1 - PF1)$ |
| I2 | AC current L2 | LF2 | Power factor phase 2 $\text{sgn}Q2 \cdot (1 - PF2)$ |
| I3 | AC current L3 | LF3 | Power factor phase 3 $\text{sgn}Q3 \cdot (1 - PF3)$ |
| Ir | Rated value of the input current | c | Factor for the intrinsic error |
| IM | Average value of the currents $(I1 + I2 + I3) / 3$ | R | Output load |
| IMS | Average value of the currents and sign of the active power (P) | Rn | Rated burden |
| IB | RMS value of the current with wire setting range (bimetal measuring function) | H | Power supply |
| IBT | Response time for IB | Hn | Rated value of the power supply |
| BS | Slave pointer function for the measurement of the RMS value IB | CT | c.t. ratio |
| BST | Response time for BS | VT | v.t. ratio |
| ϕ | Phase-shift between current and voltage | | |
| F | Frequency of the input variable | | |
| Fn | Rated frequency | | |
| P | Active power of the system $P = P1 + P2 + P3$ | | |
| P1 | Active power phase 1 (phase-to-neutral L1 – N) | | |
| P2 | Active power phase 2 (phase-to-neutral L2 – N) | | |
| P3 | Active power phase 3 (phase-to-neutral L3 – N) | | |

Applicable standards and regulations

| | |
|---|--|
| IEC 688 or EN 60 688 | Electrical measuring transducers for converting AC electrical variables into analogue and digital signals |
| IEC 1010 or EN 61 010 | Safety regulations for electrical measuring, control and laboratory equipment |
| iEC 529 or EN 60 529 | Protection types by case (code IP) |
| IEC 1000-4-2/-3/-4/-5/-6 | Electromagnetic compatibility for industrial-process measurement and control equipment |
| EN 55 011 | Electromagnetic compatibility of data processing and telecommunication equipment Limits and measuring principles for radio interference and information equipment |
| IEC 68-2-1/-2/-3/-6/-27 or EN 60 068-2-1/-2/-3/-6/-27 | Ambient tests -1 Cold, -2 Dry heat, -3 Damp heat, -6 Vibration, -27 Shock |
| DIN 40 110 | AC quantities |
| DIN 43 807 | Terminal markings |
| UL 94 | Tests for flammability of plastic materials for parts in devices and appliances |

Technical data

Measuring input

| | |
|--|---|
| Nominal input voltage: | 57.7 to 400 V (phase-to-neutral) or 100 to 693 V (phase-to-phase) |
| Nominal input current: | 1 to 6 A |
| Admissible measuring range end values: | See page 4 under "System response", column "Condition", and pages 9 and 10 under "Description 13 and 14" |
| Waveform: | Sinusoidal |
| Rated frequency: | 50 or 60 Hz |
| Consumption [VA]: | Voltage circuit: $U^2 / 400 \text{ k}\Omega$ with external power supply Current circuit: $\leq I^2 \cdot 0,01 \Omega$ |

Thermal rating of inputs

| Input variable | Number of inputs | Duration of overload | Interval between two overloads |
|---|------------------|----------------------|--------------------------------|
| Current circuit 400 V single-phase AC system 693 V three-phase system | | | |
| 12 A | — | contin. | — |
| 120 A | 10 | 1 s | 100 s |
| 120 A | 5 | 3 s | 5 min. |
| 250 A | 1 | 1 s | 1 hour |
| Voltage circuit | | | |
| 480 V/831 V ¹ | — | contin. | — |
| 600 V/1040 V ¹ | 10 | 10 s | 10 s |
| 800 V/1386 V ¹ | 10 | 1 s | 10 s |

¹ Maximum 264 V across the power supply when it is obtained from the measured variable with a power supply unit for 85...230 V DC/AC and maximum 69 V with a power supply unit for 24...60 V DC/AC.

Analogue outputs

For the outputs A, B and C:

| Output variable Y | Impressed DC current | Impressed DC voltage |
|---|--|--|
| Full scale Y2 | $1 \leq Y2 \leq 20 \text{ mA}$ | $5 \leq Y2 \leq 10 \text{ V}$ |
| Limits of output signal for input overload and/or | $R = 0$ | $1.2 \cdot Y2$ |
| | $R \rightarrow \infty$ | 30 V |
| Rated useful range of output load | $0 \leq \frac{7.5 \text{ V}}{Y2} \leq \frac{15 \text{ V}}{Y2}$ | $\frac{Y2}{2 \text{ mA}} \leq \frac{Y2}{1 \text{ mA}} \leq \infty$ |
| AC component of output signal (peak-to-peak) | $\leq 0.02 Y2$ | $\leq 0.02 Y2$ |

The outputs A, B and C may be either short or open-circuited. They are electrically insulated from each other and from all other circuits (floating).

All the full-scale output values can be reduced subsequently using the programming software, but a supplementary error results.

SINEAX M 563 with 3 analogue outputs

Programmable multi-transducer for industry

Reference conditions

| | |
|-------------------------|---|
| Ambient temperature: | 15 ... 30 °C |
| Pre-conditioning: | 30 min. acc. to EN 60 688 |
| Input variable: | Rated useful range |
| Power supply: | H = H _n ± 1% |
| Active/reactive factor: | cosφ = 1 resp. sinφ = 1 |
| Frequency: | 50 or 60 Hz |
| Waveform: | Sinusoidal, form factor 1.1107 |
| Output load: | DC current output: $R_n = \frac{7.5 \text{ V}}{Y_2} \pm 1\%$ DC voltage output: $R_n = \frac{Y_2}{1 \text{ mA}} \pm 1\%$ |
| Miscellaneous: | EN 60 688 |

| | |
|---------------------------------------|---|
| Duration of the measurement cycle: | Approx. 0.6 to 1.6 s at 50 Hz, depending on measured variable and programming |
| Response time: | 1 ... 2 times the measurement cycle |
| Factor c (the highest value applies): | |

| | |
|---|--|
| Linear characteristic: | $c = \frac{1 - \frac{Y_0}{Y_2}}{1 - \frac{X_0}{X_2}}$ or c = 1 |
| Bent characteristic: X ₀ ≤ X ≤ X ₁ | $c = \frac{Y_1 - Y_0}{X_1 - X_0} \cdot \frac{X_2}{Y_2}$ or c = 1 |
| X ₁ < X ≤ X ₂ | $c = \frac{1 - \frac{Y_1}{Y_2}}{1 - \frac{X_1}{X_2}}$ or c = 1 |

System response

Accuracy class: (the reference value is the full-scale value Y₂)

| Measured variable X | Condition | Accuracy class ¹⁾ |
|---|--|------------------------------|
| System: Active, reactive and apparent power | 0.5 ≤ X ₂ /S _r ≤ 1.5 0.3 ≤ X ₂ /S _r < 0.5 | 0.5 c 1.0 c |
| Phase: Active, reactive and apparent power | 0.167 ≤ X ₂ /S _r ≤ 0.5 0.1 ≤ X ₂ /S _r < 0.167 | 0.5 c 1.0 c |
| Power factor, active power and reactive power | 0.5S _r ≤ S ≤ 1.5 S _r , (X ₂ - X ₀) = 2 | 0.5 c |
| | 0.5S _r ≤ S ≤ 1.5 S _r , 1 ≤ (X ₂ - X ₀) < 2 | 1.0 c |
| | 0.5S _r ≤ S ≤ 1.5 S _r , 0.5 ≤ (X ₂ - X ₀) < 1 | 2.0 c |
| | 0.1S _r ≤ S < 0.5 S _r , (X ₂ - X ₀) = 2 | 1.0 c |
| | 0.1S _r ≤ S < 0.5 S _r , 1 ≤ (X ₂ - X ₀) < 2 | 2.0 c |
| | 0.1S _r ≤ S < 0.5 S _r , 0.5 ≤ (X ₂ - X ₀) < 1 | 4.0 c |
| AC voltage | 0.1 U _r ≤ U ≤ 1.2 U _r | 0.5 c |
| AC current / current averages | 0.1 I _r ≤ I ≤ 1.2 I _r | 0.5 c |
| System frequency | 0.1 U _r ≤ U ≤ 1.2 U _r resp. 0.1 I _r ≤ I ≤ 1.2 I _r | 0.15 + 0.03 c |

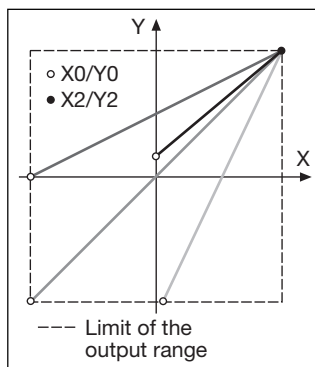

Fig. 4. Examples of settings with linear characteristic.

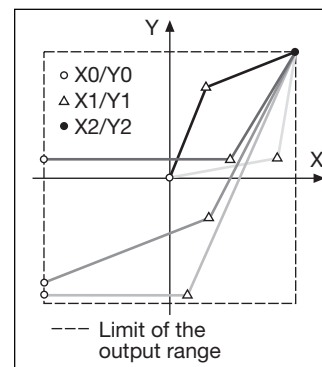

Fig. 5. Examples of settings with bent characteristic.

(System response inversely configurable)

Influencing quantities and permissible variations

Acc. to EN 60 688

Safety

| | |
|---|--|
| Protection class: | II (protection isolated, EN 61 010-1) |
| Enclosure protection: | IP 40, housing (test wire, EN 60 529) IP 20, terminals (test finger, EN 60 529) |
| Pollution degree: | 2 |
| Installation category: | III (with ≤ 300 V versus earth) II (with > 300 V versus earth) |
| Insulation test (versus earth): Inputs: | 300 V ²⁾ 600 V ³⁾ |
| Power supply: | 230 V |
| Outputs: | 40 V |

²⁾ Overvoltage category III

³⁾ Overvoltage category II

¹⁾ Basic accuracy 1,0 c for applications with phase-shift

Surge test: 5 kV; 1.2/50 μ s; 0.5 Ws

Test voltage: 50 Hz, 1 min. acc. to EN 61 010-1

3700 V, inputs versus all other circuits as well as outer surface

2200 V, input circuits versus each other

3700 V, power supply versus outputs and outer surface

490 V, outputs versus each other and versus outer surface

Mounting: For snapping onto top-hat rail (35 \times 15 mm or 35 \times 7.5 mm) acc. to EN 50 022

Orientation: Any

Weight: Approx. 0.35 kg

Terminals

Type: Screw terminals with wire guards

Max. wire gauge: \leq 4.0 mm² single wire or 2 \times 2.5 mm² fine wire

Ambient tests

EN 60 068-2-6: Vibration

Acceleration: \pm 2 g

Frequency range: 10 ... 150 ... 10 Hz, rate of frequency sweep: 1 octave/minute

Number of cycles: 10, in each of the three axes

EN 60 068-2-27: Shock

Acceleration: 3 \times 50 g
3 shocks each in 6 directions

EN 60 068-2-1/-2/-3: Cold, dry heat, damp heat

Power supply \rightarrow

DC, AC power pack (DC or 50 ... 60 Hz)

Table 1: Rated voltages and tolerances

| Rated voltage U_N | Tolerance |
|---------------------|-------------------|
| 24 ... 60 V DC/AC | DC – 15 ... + 33% |
| 85 ... 230 V DC/AC | AC \pm 15% |

Consumption: \leq 5 W resp. \leq 7 VA

Programming connector on transducer

The programming connector on the transducer is connected by the programming cable PRKAB 560 to the RS-232 interface on the PC. The electrical insulation between the two is provided by the programming cable.

Installation data

Housing: Housing **P20/105**
See Section "Dimensioned drawings"

Housing material: Lexan 940 (polycarbonate), flammability class V-0 acc. to UL 94, self-extinguishing, non-dripping, free of halogen

Ambient conditions

Variations due to ambient temperature: \pm 0.2% / 10 K

Nominal range of use for temperature: 0...15...30...45 $^{\circ}$ C (usage group II)

Operating temperature: – 10 to + 55 $^{\circ}$ C

Storage temperature: – 40 to + 85 $^{\circ}$ C

Annual mean relative humidity: \leq 75%

Dimensioned drawings

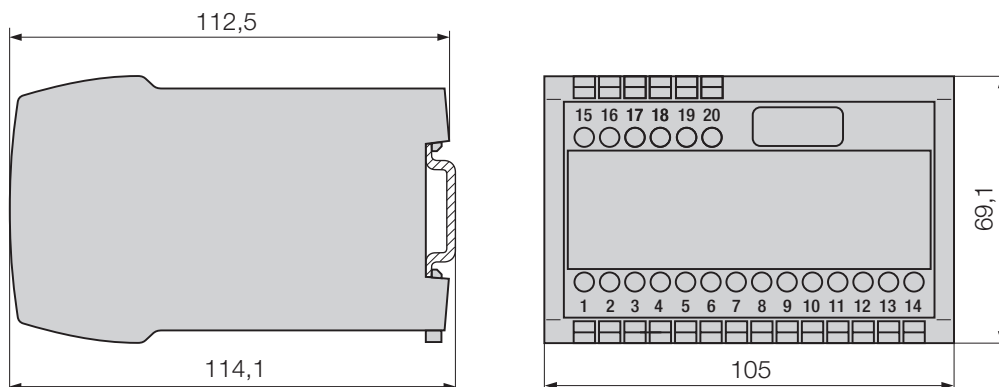

Fig. 6. SINEAX M 563 in housing P20/105 clipped onto a top-hat rail (35 \times 15 mm or 35 \times 7.5 mm, acc. to EN 50 022).

SINEAX M 563 with 3 analogue outputs

Programmable multi-transducer for industry

Table 2: SINEAX M 563 available as standard versions (3 analogue outputs)

The two versions of the transducer below programmed with the **basic** configuration are available ex stock. It is only necessary to quote the **Order No.:**

| Description / Basic programming | | Marking | Order No. |
|--|--|---------|-----------|
| 1. Mechanical design: | Housing P20/105 for rail mounting | 563 - 4 | |
| 2. Rated input frequency: | 50 Hz | 1 | |
| 3. Power supply / connection: | 24... 60 V DC/AC, external connection (standard) | 1 | 146 458 |
| | 85...230 V DC/AC, external connection (standard) | 2 | 146 440 |
| 4. Full-scale output signal, output A: | Y2 = 20 mA | 1 | |
| 5. Full-scale output signal, output B: | Y2 = 20 mA | 1 | |
| 6. Full-scale output signal, output C: | Y2 = 20 mA | 1 | |
| 7. Test certificate: | None supplied | 0 | |
| 8. Configuration: | Basic configuration | 0 | |
| See Table 3 "Ordering Information" | | | |
| Basic configuration | | | |
| Input data | | | |
| 9. Application: | 4-wire, 3-phase system asymmetric load (NPS) | H | |
| 10. Nominal input voltage: | Rated value $U_r = 100$ V | A | |
| 11. Nominal input current: | Rated value $I_r = 2$ A | 9 | |
| 12. Primary rating: | Without specification of primary rating | 0 | |
| Output A | | | |
| 13. Meas. variable/meas. range (part 1): | P1; X0 = 115.47 W; X2 = 115.47 W | 2 | |
| 14. Meas. variable/meas. range (part 2): | Not used | 0 | |
| 15. Signal range/system response: | Y0 = - 20 mA; Y2 = 20 mA | 1 | |
| 16. Characteristic: | Linear | 1 | |
| 17. Limits: | Standard | 1 | |
| Output B | | | |
| 18. Meas. variable/meas. range (part 1): | P2; X0 = 115.47 W; X2 = 115.47 W | 2 | |
| 19. Meas. variable/meas. range (part 2): | Not used | 0 | |
| 20. Signal range/system response: | Y0 = - 20 mA; Y2 = 20 mA | 1 | |
| 21. Characteristic: | Linear | 1 | |
| 22. Limits: | Standard | 1 | |
| Output C | | | |
| 23. Meas. variable/meas. range (part 1): | P3; X0 = 115.47 W; X2 = 115.47 W | 2 | |
| 24. Meas. variable/meas. range (part 2): | Not used | 0 | |
| 25. Signal range/system response: | Y0 = - 20 mA; Y2 = 20 mA | 1 | |
| 26. Characteristic: | Linear | 1 | |
| 27. Limits: | Standard | 1 | |

The complete Order Code 563-4... .. according to "Table 3: Ordering information" should be stated for other versions.

Table 3: Ordering information

| DESCRIPTION | MARKING |
|---|-----------------------|
| 1. Mechanical design Housing P20/105 for rail mounting | 563 - 4 |
| 2. Nominal input frequency 1) 50 Hz | 1 |
| 2) 60 Hz | 2 |
| 3. Power supply / Connection 1) 24 ... 60 V DC/AC, external connection (standard) | 1 |
| 2) 85 ... 230 V DC/AC, external connection (standard) | 2 |
| 3) 24 ... 60 V AC, internal connection from measuring input | 3 |
| 4) 85 ... 230 V AC, internal connection from measuring input | 4 |
| Lines 3 and 4: Not allowed with application E, F and J in feature 9 Line 3: Not allowed with nominal input voltage > 60 V _{LL} (lines A and Z in feature 10) Line 4: Not allowed with nominal input voltage 57.74 V L-N (line 1 in feature 10) Please refer to remark under feature 10 | |
| 4. Output signal final value, output A 1) Output A, Y2 = 20 mA (standard) | 1 |
| 9) Output A, Y2 [mA] | (1 ≤ Y2 < 20 mA) 9 |
| Z) Output A, Y2 [V] | (5 ≤ Y2 ≤ 10 V) Z |
| 5. Output signal final value, output B 1) Output B, Y2 = 20 mA (standard) | 1 |
| 9) Output B, Y2 [mA] | (1 ≤ Y2 < 20 mA) 9 |
| Z) Output B, Y2 [V] | (5 ≤ Y2 ≤ 10 V) Z |
| 6. Output signal final value, output C 1) Output C, Y2 = 20 mA (standard) | 1 |
| 9) Output C, Y2 [mA] | (1 ≤ Y2 < 20 mA) 9 |
| Z) Output C, Y2 [V] | (5 ≤ Y2 ≤ 10 V) Z |
| 7. Test records 0) Without test records | 0 |
| D) With test records in German | D |
| E) With test records in English | E |
| 8. Configuration 0) Basic configuration programmed (see table 2) | 0 |
| 9) Programmed to order | 9 |
| Line 0: No further details are necessary when specifying the basic configuration. Not allowed with internal power supply from measuring input. Line 9: The order must include a full specification of the following features 9 to 27 by means of a completely filled in form W 2407e with the configuration information. | |

Table 3 continued on next page!

SINEAX M 563 with 3 analogue outputs

Programmable multi-transducer for industry

Continuation "Table 3: Ordering Information"

| DESCRIPTION | MARKING |
|--|---------|
| 9. Application (system) | |
| A) Single-phase AC | A |
| B) 4-wire, 3-phase symmetric load | B |
| C) 3-wire, 3-phase symmetric load | C |
| D) 3-wire, 3-phase symmetric load, phase-shift U_{L1-L2} / I_{L1}^* | D |
| E) 3-wire, 3-phase symmetric load, phase-shift U_{L3-L1} / I_{L1}^* | E |
| F) 3-wire, 3-phase symmetric load, phase-shift U_{L2-L3} / I_{L1}^* | F |
| G) 3-wire, 3-phase asymmetric load | G |
| H) 4-wire, 3-phase asymmetric load | H |
| J) 4-wire, 3-phase asymmetric load, open-Y | J |
| Lines E, F, J: Not possible with power supply from measuring input! | |
| 10. Nominal input voltage | |
| 1) Rated value $U_r = 57.74$ V phase-to-neutral | 1 |
| 9) Rated value $U_r [V_{L-N}]$: <input type="text"/> (57.74 $V_{L-N} < U_r \leq 400 V_{L-N}$) ¹ | 9 |
| A) Rated value $U_r = 100$ V phase-to-phase | A |
| Z) Rated value $U_r [V_{L-L}]$: <input type="text"/> (100 $V_{L-L} < U_r \leq 693 V_{L-L}$) ¹ | Z |
| ¹ Max. 230 V with power supply from measuring input (feature 3, line 4)! The transducer is only valid for the rated power supply range when the power supply is being taken from the measuring input (symmetrically loaded single-phase and four-wire three-phase supply: L_{1-N} ; otherwise L_{1-L2}). Lines 1 and 9: Only for application A and B Lines A and Z: Only for application C to J | |
| 11. Nominal input current | |
| 1) Rated value $I_r = 1$ A | 1 |
| 2) Rated value $I_r = 5$ A | 2 |
| 9) Rated value I_r [A] <input type="text"/> (1 A < $I_r \leq 6$ A) | 9 |
| 12. Primary rating (voltage and current transformer) | |
| 0) Without specification of primary rating | 0 |
| 9) VT = <input type="text"/> kV CT = <input type="text"/> A | 9 |
| Line 9: Specify transformer ratio primary, e.g. 33 kV, 1000 A The secondary ratings must correspond to the rated input voltage and current specified for feature 10, respectively 11. | |

* Basic accuracy 1.0 c

Table 3 continued on next page!

Continuation "Table 3: Ordering information"

| DESCRIPTION | Application | | | Marking |
|--|--|--|-----|---------|
| | A...F | G | H/J | |
| 13. Output A, measured variable, range Part 1 (power, power factor, frequency) | | | | |
| 0) Part 1 not used | | | | 0 |
| 1) P System X0: X2: | ● | ● | ● | 1 |
| 2) P1 L1 X0: X2: | | | ● | 2 |
| 3) P2 L2 X0: X2: | | | ● | 3 |
| 4) P3 L3 X0: X2: | | | ● | 4 |
| 5) Q System X0: X2: | ● | ● | ● | 5 |
| 6) Q1 L1 X0: X2: | | | ● | 6 |
| 7) Q2 L2 X0: X2: | | | ● | 7 |
| 8) Q3 L3 X0: X2: | | | ● | 8 |
| A) S System X0: X2: | ● | ● | ● | A |
| B) S1 L1 X0: X2: | | | ● | B |
| C) S2 L2 X0: X2: | | | ● | C |
| D) S3 L3 X0: X2: | | | ● | D |
| E) PF System X0: X2: | ● | ● | ● | E |
| F) PF1 L1 X0: X2: | | | ● | F |
| G) PF2 L2 X0: X2: | | | ● | G |
| H) PF3 L3 X0: X2: | | | ● | H |
| J) QF System X0: X2: | ● | ● | ● | J |
| K) QF1 L1 X0: X2: | | | ● | K |
| L) QF2 L2 X0: X2: | | | ● | L |
| M) QF3 L3 X0: X2: | | | ● | M |
| N) LF System X0: X2: | ● | ● | ● | N |
| P) LF1 L1 X0: X2: | | | ● | P |
| Q) LF2 L2 X0: X2: | | | ● | Q |
| R) LF3 L3 X0: X2: | | | ● | R |
| S) F Frequency X0: X2: | ● | ● | ● | S |
| Meas. variable: | Initial range X0 | Final range X2 | | |
| P, Q System | $X2 \leq X0 \leq 0.8 X2$ | $0.3 \leq X2/Sr \leq 1.5$ | | |
| P, Q L1/L2/L3 | $X2 \leq X0 \leq 0.8 X2$ | $0.1 \leq X2/Sr \leq 0.5$ | | |
| S System | $0 \leq X0 \leq 0.8 X2$ | $0.3 \leq X2/Sr \leq 1.5$ | | |
| S L1/L2/L3 | $0 \leq X0 \leq 0.8 X2$ | $0.1 \leq X2/Sr \leq 0.5$ | | |
| PF, QF, LF | $1 \leq X0 \leq (X2 - 0.5)$ | $0 \leq X2 \leq 1$ | | |
| F | $45 \text{ Hz} \leq X0 \leq (X2 - 1) \text{ Hz}$ | $(X0 + 1) \text{ Hz} \leq X2 \leq 65 \text{ Hz}$ | | |

Table 3 continued on next page!

SINEAX M 563 with 3 analogue outputs

Programmable multi-transducer for industry

Continuation "Table 3: Ordering information"

| DESCRIPTION | Application | | | Marking |
|--|-------------|---|-----|---------|
| | A...F | G | H/J | |
| 14. Output A, measured variable, range | | | | |
| Part 2 (current, voltage) | | | | |
| 0) Part 2 not used | | | | 0 |
| 1) I System X0: X2: | ● | | | 1 |
| 2) I1 L1 X0: X2: | | ● | ● | 2 |
| 3) I2 L2 X0: X2: | | ● | ● | 3 |
| 4) I3 L3 X0: X2: | | ● | ● | 4 |
| 5) IB System (15 min) X0: X2: | ● | | | 5 |
| 6) IB1 L1 (15 min) X0: X2: | | ● | ● | 6 |
| 7) IB2 L2 (15 min) X0: X2: | | ● | ● | 7 |
| 8) IB3 L3 (15 min) X0: X2: | | ● | ● | 8 |
| A) BS System (15 min) X0: X2: | ● | | | A |
| B) BS1 L1 (15 min) X0: X2: | | ● | ● | B |
| C) BS2 L2 (15 min) X0: X2: | | ● | ● | C |
| D) BS3 L3 (15 min) X0: X2: | | ● | ● | D |
| E) IM System X0: X2: | | ● | ● | E |
| F) IMS System X0: X2: | | ● | ● | F |
| G) U System X0: X2: | ● | | | G |
| H) U1N L1-N X0: X2: | | | ● | H |
| J) U2N L2-N X0: X2: | | | ● | J |
| K) U3N L3-N X0: X2: | | | ● | K |
| L) U12 L1-L2 X0: X2: | | ● | ● | L |
| M) U23 L2-L3 X0: X2: | | ● | ● | M |
| N) U31 L3-L1 X0: X2: | | ● | ● | N |
| Meas. variable: Initial range X0 Final range X2 | | | | |
| I, I1, I2, I3 0 ≤ X0 ≤ 0.8 X2 0.5 Ir ≤ X2 ≤ 1.2 Ir | | | | |
| IB, IBS X0 = 0 0.5 Ir ≤ X2 ≤ 1.2 Ir | | | | |
| IM 0 ≤ X0 ≤ 0.8 X2 0.5 Ir ≤ X2 ≤ 1.2 Ir | | | | |
| IMS -X2 ≤ X0 ≤ 0.8 X2 0.5 Ir ≤ X2 ≤ 1.2 Ir | | | | |
| U System 0 ≤ X0 ≤ 0.9 X2 0.8 Ur ≤ X2 ≤ 1.2 Ur | | | | |
| U L1-L2 0 ≤ X0 ≤ 0.9 X2 0.8 Ur ≤ X2 ≤ 1.2 Ur | | | | |
| U L2-L3 0 ≤ X0 ≤ 0.9 X2 0.8 Ur ≤ X2 ≤ 1.2 Ur | | | | |
| U L3-L1 0 ≤ X0 ≤ 0.9 X2 0.8 Ur ≤ X2 ≤ 1.2 Ur | | | | |
| U L1-N 0 ≤ X0 ≤ 0.9 X2 0.8 Ur/√3 ≤ X2 ≤ 1.2 Ur/√3 | | | | |
| U L2-N 0 ≤ X0 ≤ 0.9 X2 0.8 Ur/√3 ≤ X2 ≤ 1.2 Ur/√3 | | | | |
| U L3-N 0 ≤ X0 ≤ 0.9 X2 0.8 Ur/√3 ≤ X2 ≤ 1.2 Ur/√3 | | | | |
| 15. Output A, signal range, system response | | | | |
| 0) Not used | | | | 0 |
| 1) Signal (Y0 ... Y2SW): -Y2 ... Y2 | | | | 1 |
| 2) Signal (Y0 ... Y2SW): 0 ... Y2 | | | | 2 |
| 3) Signal (Y0 ... Y2SW): 0,2 Y2 ... Y2 | | | | 3 |
| 9) Signal Y0 ... Y2SW: | | | | 9 |
| A) Signal inversely (Y2SW ... Y0): Y2 ... Y2 | | | | A |
| B) Signal inversely (Y2SW ... Y0): Y2 ... 0 | | | | B |
| C) Signal inversely (Y2SW ... Y0): Y2 ... 0,2 Y2 | | | | C |
| Z) Signal inversely Y2SW ... Y0: | | | | Z |
| Lines 9 and Z: Y2 = selected final value in feature 4. Specify Y0 and Y2SW in mA or V, within the limits 1 ≤ Y2SW ≤ Y2 (additional error!); -Y2SW ≤ Y0 ≤ 0,2 Y2SW | | | | |

Table 3 continued on next page!

Continuation "Table 3: Ordering information"

| DESCRIPTION | Application | | | Marking |
|---|-------------|---|-----|---------|
| | A...F | G | H/J | |
| 16. Output A, characteristic | | | | |
| 0) Not used | | | | 0 |
| 1) Characteristic linear | | | | 1 |
| 9) Characteristic kinked X1: [] Y1: [] | | | | 9 |
| Line 9: Specify kink point, X1 (input) as value of the measured quantity, Y1 (output) in mA or V, within the limits $(X0 + 0.015 X2) \leq X1 \leq 0.985 X2$; $Y0 \leq Y1 \leq Y2SW$ | | | | |
| 17. Output A, limitation | | | | |
| 0) Not used | | | | 0 |
| 1) Limitation Standard ($Y_{min} = Y0 - 0.2 Y2SW$; $Y_{max} = 1.2 Y2SW$) | | | | 1 |
| 9) Limitation Ymin: [] Ymax.: [] | | | | 9 |
| $(Y0 - 0.2 Y2SW) \leq Y_{min} \leq Y0$; $Y2SW \leq Y_{max} \leq 1.2 Y2SW$ | | | | |
| 18. Output B, measured variable, range | Application | | | |
| Part 1 (power, power factor, frequency) | A...F | G | H/J | |
| 0) Part 1 not used | | | | 0 |
| 1) P System X0: [] X2: [] | ● | ● | ● | 1 |
| 2) P1 L1 X0: [] X2: [] | | | ● | 2 |
| 3) etc. analogue output A, feature 13 | | | ● | 3 |
| 19. Output B, measured variable, range | | | | |
| Part 2 (current, voltage) | | | | |
| 0) Part 2 not used | | | | 0 |
| 1) I System X0: [] X2: [] | ● | | | 1 |
| 2) I1 L1 X0: [] X2: [] | | ● | ● | 2 |
| 3) etc. analogue output A, feature 14 | | ● | ● | 3 |
| 20. Output B, signal range, system response | | | | |
| 0) Not used | | | | 0 |
| 1) Signal ($Y0 \dots Y2SW$): $-Y2 \dots Y2$ | | | | 1 |
| 2) Signal ($Y0 \dots Y2SW$): $0 \dots Y2$ | | | | 2 |
| 3) Signal ($Y0 \dots Y2SW$): $0,2 Y2 \dots Y2$ | | | | 3 |
| 9) Signal $Y0 \dots Y2SW$: [] [] [] | | | | 9 |
| A) Signal inversely ($Y2SW \dots Y0$): $Y2 \dots -Y2$ | | | | A |
| B) Signal inversely ($Y2SW \dots Y0$): $Y2 \dots 0$ | | | | B |
| C) Signal inversely ($Y2SW \dots Y0$): $Y2 \dots 0,2 Y2$ | | | | C |
| Z) Signal inversely $Y2SW \dots Y0$: [] [] [] | | | | Z |
| Lines 9 and Z: $Y2 =$ selected final value in feature 4. Specify $Y0$ and $Y2SW$ in mA or V, within the limits $1 \leq Y2SW \leq Y2$ (additional error!); $-Y2SW \leq Y0 \leq 0,2 Y2SW$ | | | | |
| 21. Output B, characteristic | | | | |
| 0) Not used | | | | 0 |
| 1) Characteristic linear | | | | 1 |
| 9) Characteristic kinked X1: [] Y1: [] | | | | 9 |
| Line 9: Specify kink point, X1 (input) as value of the measured quantity, Y1 (output) in mA or V, within the limits $(X0 + 0.015 X2) \leq X1 \leq 0.985 X2$; $Y0 \leq Y1 \leq Y2SW$ | | | | |
| 22. Output B, limitation | | | | |
| 0) Not used | | | | 0 |
| 1) Limitation Standard ($Y_{min} = Y0 - 0.2 Y2SW$; $Y_{max} = 1.2 Y2SW$) | | | | 1 |
| 9) Limitation Ymin: [] Ymax.: [] | | | | 9 |
| $(Y0 - 0.2 Y2SW) \leq Y_{min} \leq Y0$; $Y2SW \leq Y_{max} \leq 1.2 Y2SW$ | | | | |

Table 3 continued on next page!



SINEAX M 563 with 3 analogue outputs

Programmable multi-transducer for industry

Continuation "Table 3: Ordering Information"

| DESCRIPTION | Application | | | Marking |
|--|-------------|---|-----|---------|
| | A...F | G | H/J | |
| 23. Output C, measured variable, range Part 1 (power, power factor, frequency) | | | | |
| 0) Part 1 not used | | | | 0 |
| 1) P System X0: [] X2: [] | ● | ● | ● | 1 |
| 2) P1 L1 X0: [] X2: [] | | | ● | 2 |
| 3) etc. analogue output A, feature 13 | | | ● | 3 |
| 24. Output C, measured variable, range Part 2 (current, voltage) | | | | |
| 0) Part 2 not used | | | | 0 |
| 1) I System X0: [] X2: [] | ● | | | 1 |
| 2) I1 L1 X0: [] X2: [] | | ● | ● | 2 |
| 3) etc. analogue output A, feature 14 | | ● | ● | 3 |
| 25. Output C, signal range, system response | | | | |
| 0) Not used | | | | 0 |
| 1) Signal (Y0 ... Y2SW): - Y2 ... Y2 | | | | 1 |
| 2) Signal (Y0 ... Y2SW): 0 ... Y2 | | | | 2 |
| 3) Signal (Y0 ... Y2SW): 0,2 Y2 ... Y2 | | | | 3 |
| 9) Signal Y0 ... Y2SW: [] [] | | | | 9 |
| A) Signal inversely (Y2SW ... Y0): Y2 ... - Y2 | | | | A |
| B) Signal inversely (Y2SW ... Y0): Y2 ... 0 | | | | B |
| C) Signal inversely (Y2SW ... Y0): Y2 ... 0,2 Y2 | | | | C |
| Z) Signal inversely Y2SW ... Y0: [] [] | | | | Z |
| Lines 9 and Z: Y2 = selected final value in feature 4. Specify Y0 and Y2SW in mA or V, within the limits $1 \leq Y2SW \leq Y2$ (additional error!); $-Y2SW \leq Y0 \leq 0,2 Y2SW$ | | | | |
| 26. Output C, characteristic | | | | |
| 0) Not used | | | | 0 |
| 1) Characteristic linear | | | | 1 |
| 9) Characteristic kinked X1: [] Y1: [] | | | | 9 |
| Line 9: Specify kink point, X1 (input) as value of the measured quantity, Y1 (output) in mA or V, within the limits $(X0 + 0.015 X2) \leq X1 \leq 0.985 X2$; $Y0 \leq Y1 \leq Y2SW$ | | | | |
| 27. Output C, limitation | | | | |
| 0) Not used | | | | 0 |
| 1) Limitation Standard (Ymin = Y0 - 0.2 Y2; Ymax = 1.2 Y2) | | | | 1 |
| 9) Limitation Ymin: [] Ymax.: [] | | | | 9 |
| $(Y0 - 0.2 Y2SW) \leq Ymin \leq Y0$; $Y2SW \leq Ymax \leq 1.2 Y2SW$ | | | | |

Electrical connections

| Function | | Connect. |
|--|------------|-----------|
| Measuring input  | AC current | IL1 1 / 3 |
| | | IL2 4 / 6 |
| | | IL3 7 / 9 |
| | AC voltage | UL1 2 |
| | | UL2 5 |
| | | UL3 8 |
| | | N 11 |
| Outputs  | Analogue | - 15 |
| | | A + 16 |
| | B - 17 | |
| | B + 18 | |
| | C - 19 | |
| | C + 20 | |
| Power supply  | AC | ~ 13 |
| | | ~ 14 |
| | DC | - 13 |
| | | + 14 |
| RS 232 C interface | | |

If power supply is taken from the measured voltage internal connections are as follow:

| Application (system) | Internal connection Terminal / System |
|--|---------------------------------------|
| Single-phase AC current | 2 / 11 (L1 - N) |
| 4-wire 3-phase symmetric load | 2 / 11 (L1 - N) |
| All other (apart from feature 9, lines E, F and J) | 2 / 5 (L1 - L2) |

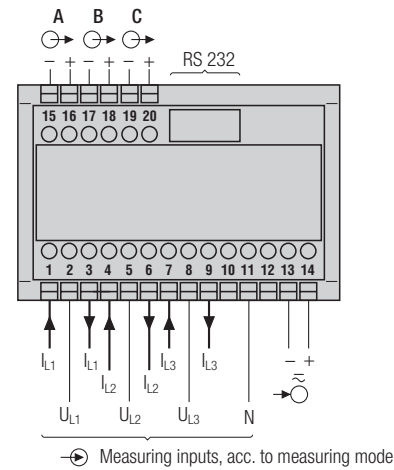

Measuring inputs

| System / Application | Terminals | | | | | | | | | | | | | | | |
|---|---|-----------------|-----------|----|---|----|----|---|---|----|---|----|---|---|----|---|
| Single-phase AC system | | | | | | | | | | | | | | | | |
| 4-wire 3-phase symmetric load I: L1 | <p>Connect the voltage according to the following table for current measurement in L2 or L3:</p> <table border="1" style="margin-left: auto; margin-right: auto;"> <thead> <tr> <th>Current transf.</th> <th colspan="2">Terminals</th> <th>2</th> <th>11</th> </tr> </thead> <tbody> <tr> <td>L2</td> <td>1</td> <td>3</td> <td>L2</td> <td>N</td> </tr> <tr> <td>L3</td> <td>1</td> <td>3</td> <td>L3</td> <td>N</td> </tr> </tbody> </table> | Current transf. | Terminals | | 2 | 11 | L2 | 1 | 3 | L2 | N | L3 | 1 | 3 | L3 | N |
| Current transf. | Terminals | | 2 | 11 | | | | | | | | | | | | |
| L2 | 1 | 3 | L2 | N | | | | | | | | | | | | |
| L3 | 1 | 3 | L3 | N | | | | | | | | | | | | |

SINEAX M 563 with 3 analogue outputs

Programmable multi-transducer for industry

| Measuring inputs | | | | | | | | | | | | | | | | |
|---|--|-----------------|-----------|----|---|----|-------|-------|----|----|-------|----|-------|----|----|----|
| System / application | Terminals | | | | | | | | | | | | | | | |
| 3-wire 3-phase symmetric load I: L1 | <p>Connect the voltage according to the following table for current measurement in L2 or L3:</p> <table border="1"> <thead> <tr> <th>Current transf.</th> <th>Terminals</th> <th>2</th> <th>5</th> <th>8</th> </tr> </thead> <tbody> <tr> <td>L2</td> <td>1 3</td> <td>L2</td> <td>L3</td> <td>L1</td> </tr> <tr> <td>L3</td> <td>1 3</td> <td>L3</td> <td>L1</td> <td>L2</td> </tr> </tbody> </table> | Current transf. | Terminals | 2 | 5 | 8 | L2 | 1 3 | L2 | L3 | L1 | L3 | 1 3 | L3 | L1 | L2 |
| Current transf. | Terminals | 2 | 5 | 8 | | | | | | | | | | | | |
| L2 | 1 3 | L2 | L3 | L1 | | | | | | | | | | | | |
| L3 | 1 3 | L3 | L1 | L2 | | | | | | | | | | | | |
| 3-wire 3-phase symmetric load Phase-shift U: L1 – L2 I: L1 | <p>Connect the voltage according to the following table for current measurement in L2 or L3:</p> <table border="1"> <thead> <tr> <th>Current transf.</th> <th>Terminals</th> <th>2</th> <th>5</th> </tr> </thead> <tbody> <tr> <td>L2</td> <td>1 3</td> <td>L2</td> <td>L3</td> </tr> <tr> <td>L3</td> <td>1 3</td> <td>L3</td> <td>L1</td> </tr> </tbody> </table> | Current transf. | Terminals | 2 | 5 | L2 | 1 3 | L2 | L3 | L3 | 1 3 | L3 | L1 | | | |
| Current transf. | Terminals | 2 | 5 | | | | | | | | | | | | | |
| L2 | 1 3 | L2 | L3 | | | | | | | | | | | | | |
| L3 | 1 3 | L3 | L1 | | | | | | | | | | | | | |
| 3-wire 3-phase symmetric load Phase-shift U: L3 – L1 I: L1 | <p>Connect the voltage according to the following table for current measurement in L2 or L3:</p> <table border="1"> <thead> <tr> <th>Current transf.</th> <th>Terminals</th> <th>8</th> <th>2</th> </tr> </thead> <tbody> <tr> <td>L2</td> <td>1 3</td> <td>L1</td> <td>L2</td> </tr> <tr> <td>L3</td> <td>1 3</td> <td>L2</td> <td>L3</td> </tr> </tbody> </table> | Current transf. | Terminals | 8 | 2 | L2 | 1 3 | L1 | L2 | L3 | 1 3 | L2 | L3 | | | |
| Current transf. | Terminals | 8 | 2 | | | | | | | | | | | | | |
| L2 | 1 3 | L1 | L2 | | | | | | | | | | | | | |
| L3 | 1 3 | L2 | L3 | | | | | | | | | | | | | |

Measuring inputs

System / application

Terminals

3-wire
3-phase
symmetric load
Phase-shift
U: L2 – L3
I: L1

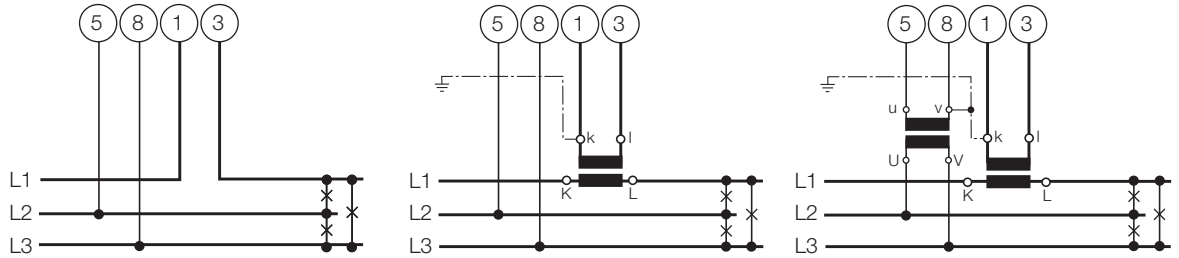

Connect the voltage according to the following table for current measurement in L2 or L3:

| Current transf. | Terminals | | 5 | 8 |
|-----------------|-----------|---|----|----|
| L2 | 1 | 3 | L3 | L1 |
| L3 | 1 | 3 | L1 | L2 |

3-wire
3-phase
asymmetric load

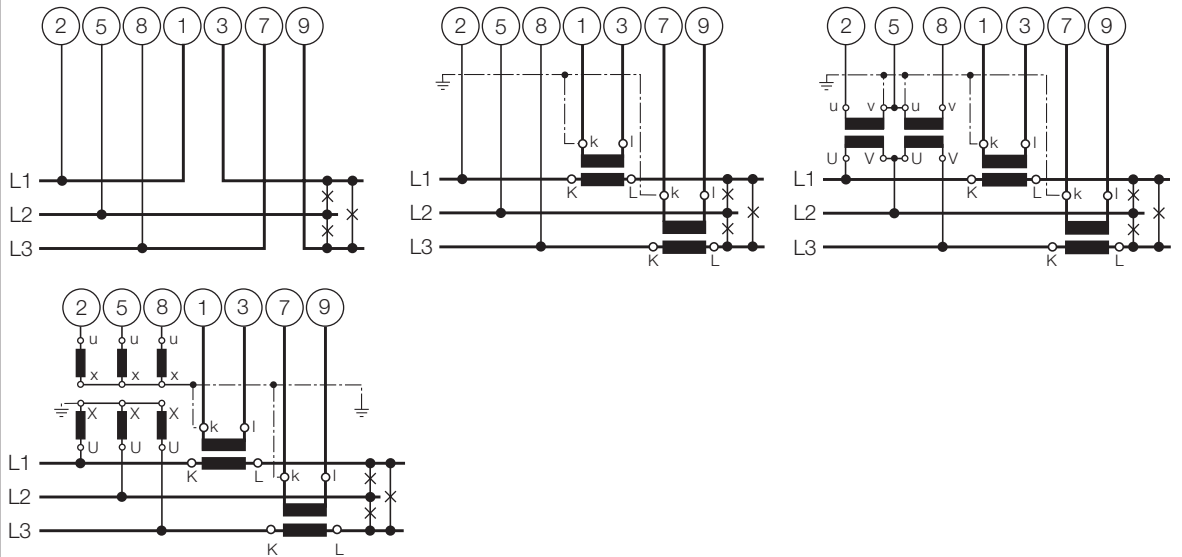

4-wire
3-phase
asymmetric load

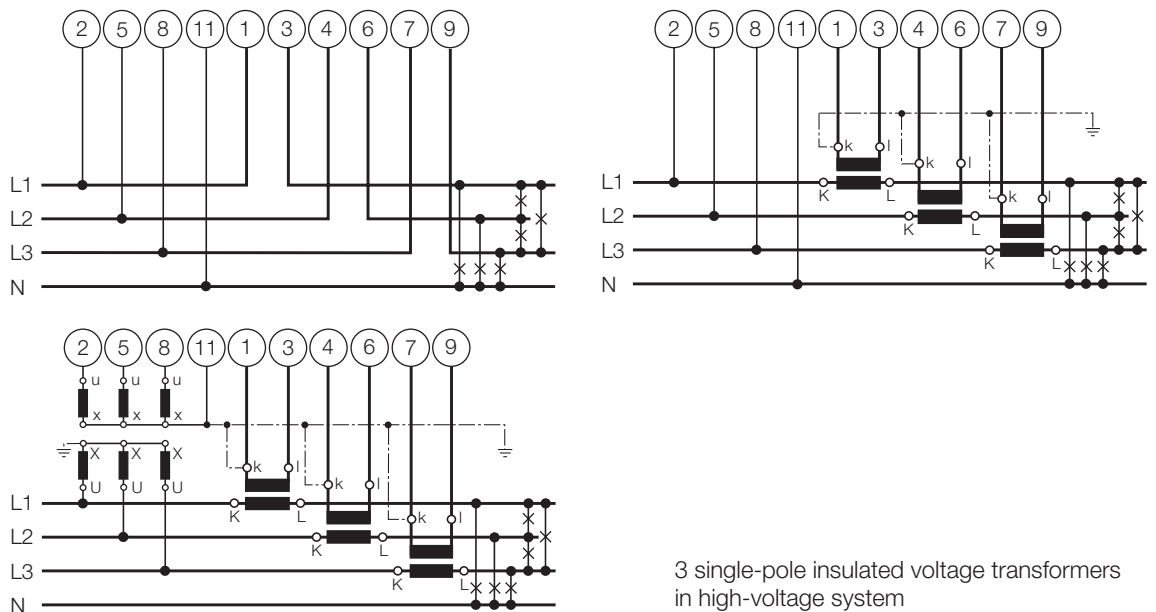

3 single-pole insulated voltage transformers in high-voltage system

SINEAX M 563 with 3 analogue outputs

Programmable multi-transducer for industry

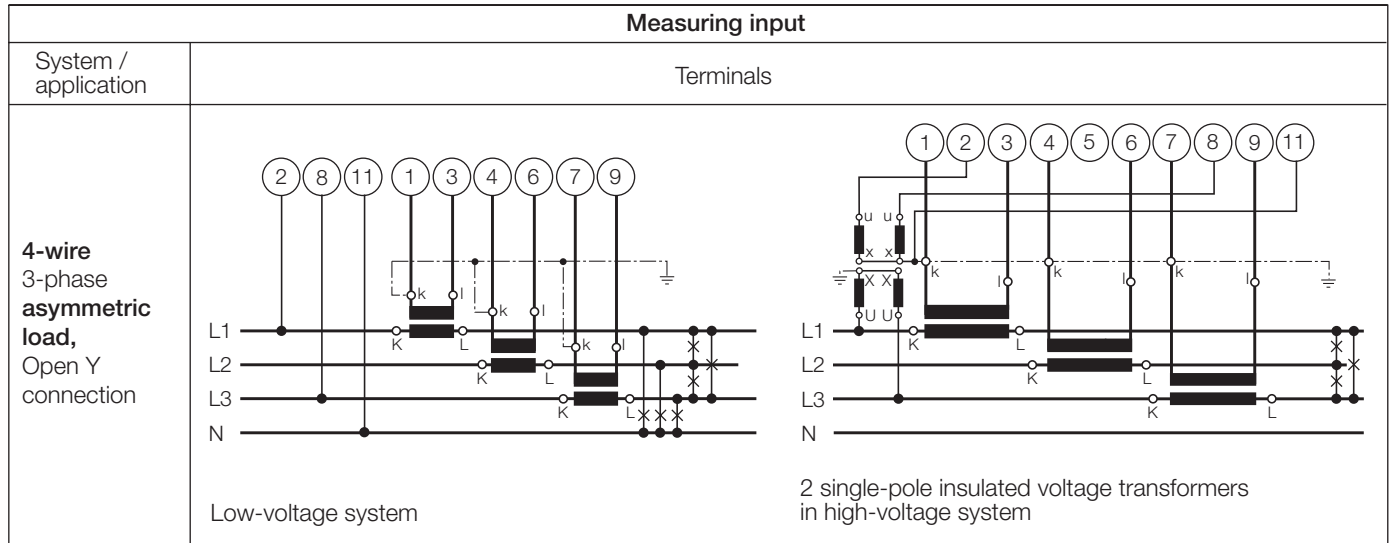

Relationship between PF, QF and LF

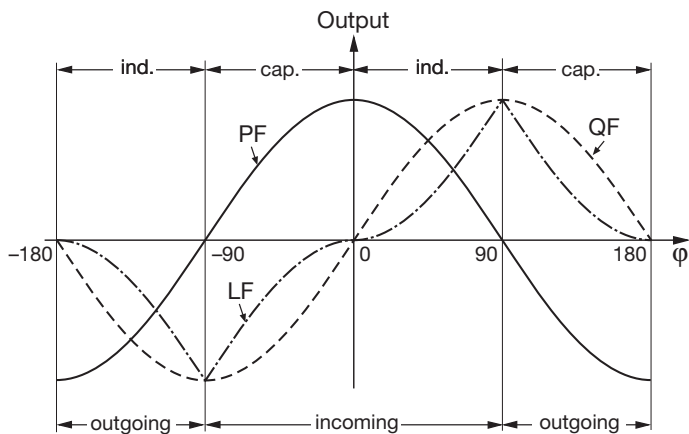

Fig. 7. Active power PF —, reactive power QF -----, power factor LF -.-.-.-.

Standard accessories

- Operating Instructions for SINEAX M 563 in three languages: German, French, English
- 1 blank type label, for recording programmed settings

Table 4: Accessories and spare parts

| Description | Order No. |
|---|-----------|
| Programming cable PRKAB 560 | 147 779 |
| Ancillary cable for SINEAX M 563 | 143 587 |
| Configuration Software M 560 for SINEAX M 563 Windows 3.1 or higher on CD in German, English, French, Italian and Dutch (Download free of charge under http://www.gmc-instruments.com) In addition, the CD contains all configuration programmes presently available for Camille Bauer products. | 146 557 |
| Operating Instructions M 563-4 B d-f-e in three languages: German, French, English | 143 579 |