

# SINEAX TI 816

## Passive DC signal isolator

without power supply,  
in carrying rail housing



### Application

The signal isolator **SINEAX TI 816** (Fig. 1) serves to electrically insulate an analogue DC signal in the range 0...20 mA which depending on version is then converted to a current or voltage signal (0...20 mA or 0...10 V). It operates passively and does not require a separate power supply, but derives the little auxiliary energy it needs from the DC signal.

Its narrow casing is designed for mounting on different types of standard rails (Fig. 2). A number of signal isolators can be mounted immediately next to each other and where there are many DC signals to be isolated can form a compact isolator block.



Fig. 1

### Features / Benefits

- Electrically insulated analogue DC signals 0...20 mA / Prevents the transfer of interference voltages and currents. Solves grounding problems in meshed signal networks
- Highly accurate / Performs its isolating function with negligible transmission error
- No power supply needed / Saves wiring costs and is easy to install in existing plants
- The device fulfils the protection requirements of the EMC guidelines (89/336/EWG) / The device bears the CE symbol for EMC. See "Table 1: Electromagnetic compatibility"
- Small and compact / Makes best use of the available space



Fig. 2

### Layout and mode of operation

The DC signal isolator comprises a DC chopper Z, an isolating stage T, a rectifier G and an oscillator O.

The chopper converts the DC input signal E to an AC signal which is transformed with electrical insulation, rectified, smoothed and appears at the output as a DC current signal A (Fig. 3, left). Ver-

sions with a DC output **voltage** signal A have a resistive burden through which the current flows (Fig. 3, right).

The chopper is controlled by the oscillator which obtains its power from the DC signal.

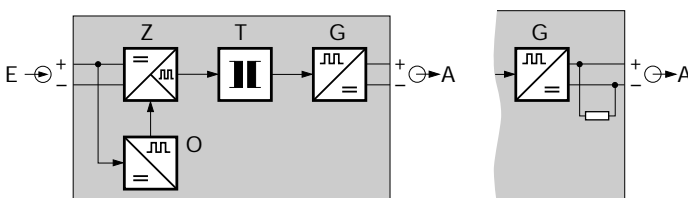

Fig. 3. Schematic diagram.

# SINEAX TI 816

## Passive DC signal isolator

### Technical data

#### Input signal E

DC current:	0...20 mA
Max. permissible current:	50 mA
Voltage limiter:	18 V $\pm$ 5% (with zener diode)
Voltage drop:	< 2 V (for 500 $\Omega$ burden)
Overshoot:	< 20 $\mu$ A (typical 5 $\mu$ A)

#### Output signal A

DC current or DC voltage:	0...20 mA or 0...10 V
Limit:	Approx. 30 mA <sup>1</sup> Approx. 15 V <sup>2</sup>
Max. burden:	600 $\Omega$ <sup>1</sup>
Internal resistance:	500 $\Omega$ <sup>2</sup>
Residual ripple:	< 20 mV ss
Time constant:	Approx. 5 ms

### Accuracy data

Error limits:	< $\pm$ 0.1% <sup>1</sup> (reference value 20 mA, linearity error included)
	< $\pm$ 0.2% <sup>2</sup> (reference value 10 V, linearity error included)

### Reference conditions:

Ambient temperature	23 °C $\pm$ 1 K
Output burden	100 $\Omega$ <sup>1</sup> $\geq$ 5 M $\Omega$ <sup>2</sup>

### Additional error:

Burden influence	< 0.2% (at 500 $\Omega$ ) <sup>1</sup>
Temperature coefficient	< 50 ppm/K

### Installation data

Mechanical design:	Carrying rail housing N12 Dimensions see section "Dimensional drawings"
Material of housing:	Lexan 940 (polycarbonate). Flammability Class V-0 acc. to UL 94, self-extinguishing, non-dripping, free of halogen

### Mounting:

### Snapping

- onto G-type rail  
acc. to EN 50 035-G32
- or
- onto top-hat rail  
acc. to EN 50 022-35x7.5

### Mounting position:

Any

### Electrical connections:

Screw terminals with wire protection  
clamps

- for 0.2 to 4 mm<sup>2</sup> non-stranded  
wires

or

- for 0.2 to 2.5 mm<sup>2</sup> stranded wires

### Weight:

Approx. 35 g

### Regulations

#### Electrical design:

Acc. to IEC 1010

#### Protection:

Housing IP 40 acc. to EN 60 529,  
Terminals IP 20

#### Test voltage:

500 Vrms, 50 Hz, 1 min.

#### Max. surge voltage:

800 V

### Ambient conditions

#### Climatic rating:

Climate class 3Z acc. to  
VDI/VDE 3540

#### Operating temperature:

–20 to + 65 °C

#### Storage temperature:

–40 to + 85 °C

#### Annual mean

#### relative humidity:

$\leq$  75% standard climatic rating

#### Seismic test:

5 g, < 200 Hz,  
2 h in each of 3 directions

#### Shock test:

50 g,  
10 shocks in each of 3 directions

<sup>1</sup> With current signal

<sup>2</sup> With voltage signal

## Table 1: Electromagnetic compatibility

Reference was made to the general standards EN 50 081-2 and EN 50 082-2

Conducted interference from the instrument	EN 55 011	Group 1, Class A
HF radiation from complete instrument	EN 55 011	Group 1, Class A
Electrostatic discharge	IEC 1000-4-2	Direct: $\pm 8$ kV air Indirect: $\pm 6$ kV contact
HF field influence on instrument	IEC 1000-4-3	80 MHz...1000 MHz: 10 V/m, 80% AM 1 kHz (ITU-frequencies, 3 V/m)
Transient burst via connections	IEC 1000-4-4	$\pm 2$ kV, 5/50 ns, 5 kHz, > 2 min. capacitively coupled
HF interference via connections	IEC 1000-4-6	0.15 to 80 MHz: 10 V, 80% AM 1 kHz (ITU-frequencies, 3 V)

The device fulfils the protection requirements of the EMC guidelines (89/336/EWG). The device bears the CE symbol for EMC.

## Table 2: Versions (stock)

There are two versions of the DC signal isolator SINEAX TI 816 both of which are available ex stock. Quoting the **order No.** is sufficient when ordering:

Description	Output signal A	Order code	Order No.
Passive DC signal isolator Input signal E: 0...20 mA, with 1 isolation and transmission channel, in carrying rail housing N12	0...20 mA	816 - 5110	990 722
	0...10 V	816 - 5111	994 089

## Electrical connections

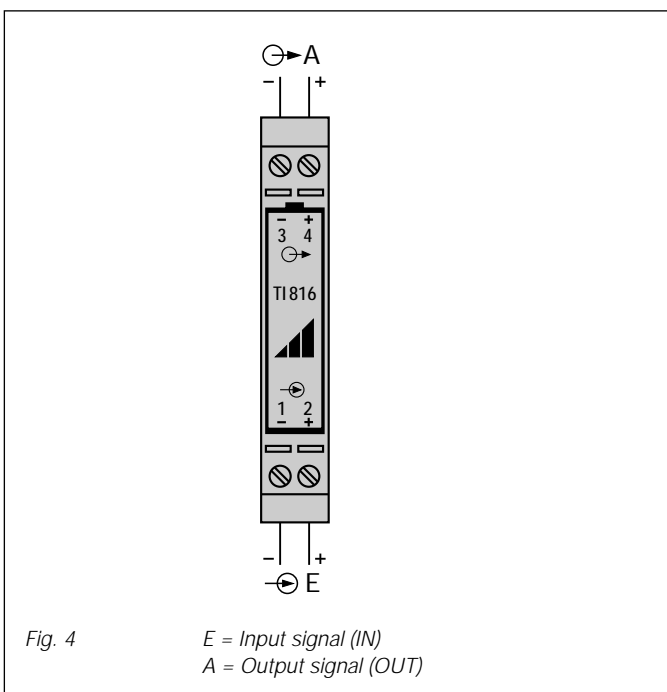

## Standard accessories

1 Operating manual each in German, French and English

# SINEAX TI 816

## Passive DC signal isolator

### Dimensional drawings

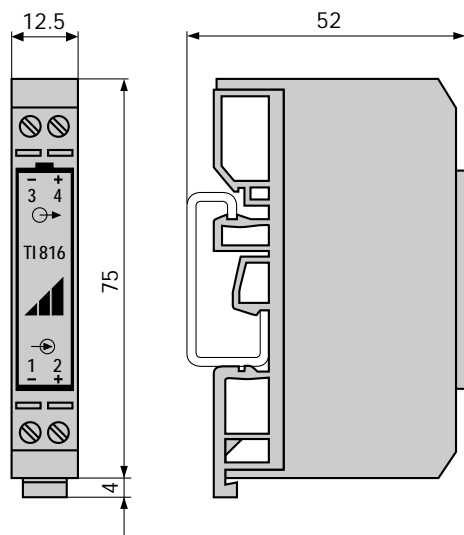

Fig. 5. SINEAX TI 816 in carrying rail housing N12 on G-type rail EN 50 035 – G 32.

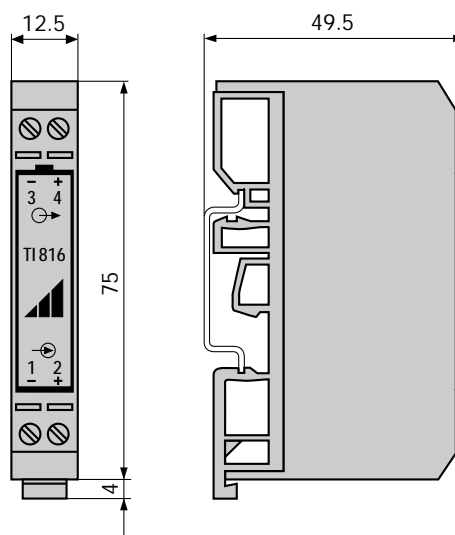

Fig. 6. SINEAX TI 816 in carrying rail housing N12 on top-hat rail EN 50 022 – 35x7.5.