

SINEAX TV 808, 2 channels

Isolating amplifier unipolar/bipolar

For electrically insulating, amplifying and converting DC signals



Application

The purpose of the isolating amplifier **SINEAX TV 808** (Fig. 1) is to electrically insulate input and output signals, respectively to amplify and/or change the signal level or type (current or voltage) of the input signals.

The amplifier fulfils all the important requirements and regulations concerning electromagnetic compatibility EMC and Safety (IEC 1010 resp. EN 61 010). It was developed and is manufactured and tested in strict accordance with the quality assurance standard ISO 9001.

The device has two channels and provides two independent isolating amplifiers in an extremely small space. The user has a wide choice of input and output ranges and can set the desired one with the aid of soldered jumpers and potentiometers.

A version with one input and two outputs is available that enables two electrically insulated outputs to be obtained from a single input signal.



Fig. 1. Isolating amplifier SINEAX TV 808-12 in housing S17 clipped onto a top-hat rail or screw hole mounting brackets pulled out.

Variants

- 252 standard input and output combinations selected by soldered jumpers
- User-specific input and/or output ranges
- Isolating amplifier with one input and two electrically insulated outputs
- Power supply 24...60 V DC/AC or 85...230 V DC/AC

Please request our data sheet TV 808-11 Le for single-channel versions.

Features / Benefits

- Electric insulation between inputs, outputs (2.3 kV) and power supply (3.7 kV) / Prevents measurement errors due to potential leakage
- Flexibility provided by more than 250 different input and output combinations selected by simply positioning soldered jumpers / Reduced stocking
- Non-standard user-specific ranges available
- AC/DC power supply / Universal
- Provision for either snapping the isolating amplifier onto top-hat rails or securing it with screws to a wall or panel
- Housing only 17.5 mm (size S17 housing) / Low space requirement

Standard versions

Inputs and outputs set to 0...20 mA. Any of the standard ranges given in the Section "Technical data, measuring inputs" are simply selected by positioning soldered jumpers. The fine adjustment is accomplished using the potentiometers "Zero" and "Span".

Table 1: Standard version with 2 inputs and 2 outputs

Standard range		Power supply	Order No.
Inputs 1 and 2	Outputs 1 and 2		
0... 20 mA	0... 20 mA	24... 60 V DC/AC	128 802
		85...230 V DC/AC	128 810

Table 2: Standard version with 1 input and 2 outputs

Standard range		Power supply	Order No.
Input 1	Outputs 1 and 2		
0... 20 mA	0... 20 mA	24... 60 V DC/AC	128 828
		85...230 V DC/AC	128 836

Please complete the Order Code 808-12.. according to "Table 4: Ordering information" for versions with user-specific input and/or output ranges.

SINEAX TV 808, 2 channels

Isolating amplifier unipolar/bipolar

Technical data

Measuring inputs →

DC current:

Standard ranges

0 ... 0.1 mA	0.2 ... 1 mA	- 0.1 ... + 0.1 mA
0 ... 0.2 mA	1 ... 5 mA	- 0.2 ... + 0.2 mA
0 ... 0.5 mA	2 ... 10 mA	- 0.5 ... + 0.5 mA
0 ... 1 mA	4 ... 20 mA	- 1 ... + 1 mA
0 ... 2 mA		- 2 ... + 2 mA
0 ... 5 mA		- 5 ... + 5 mA
0 ... 10 mA		- 10 ... + 10 mA
0 ... 20 mA		- 20 ... + 20 mA

Limit values

0...0.1 to 0...40 mA

also live-zero,

start value > 0 to ≤ 50% final value

or span 0.1 to 40 mA

between -40 and 40 mA

also bipolar asymmetrical

$R_i = 15 \Omega$

DC voltage:

Standard ranges

0 ... 0.06 V	0.2 ... 1 V	- 0.1 ... + 0.1 V
0 ... 0.1 V	1 ... 5 V	- 0.2 ... + 0.2 V
0 ... 0.2 V	2 ... 10 V	- 0.5 ... + 0.5 V
0 ... 0.5 V	4 ... 20 V	- 1 ... + 1 V
0 ... 1 V		- 2 ... + 2 V
0 ... 2 V		- 5 ... + 5 V
0 ... 5 V		- 10 ... + 10 V
0 ... 10 V		- 20 ... + 20 V
0 ... 20 V		
0 ... 40 V		

Limit values

0...0.06 to 0...40

also live-zero,

start value > 0 to ≤ 50% final value

or span 0.06 to 40 V

between -40 and 40 V

also bipolar asymmetrical

$R_i = 100 \text{ k}\Omega$

Overload:

DC current
continuously 2-fold
DC voltage
continuously 2-fold

Measuring outputs →

DC currents:

Standard ranges
0...20 mA, 4...20 mA, ± 20 mA

Limit values

0...1 to 0...20 mA
0.2...1 to 4...20 mA
-1...0...+ 1 to -20...0...+ 20 mA

Burden voltage:

12 V

External resistance:

$$R_{\text{ext max.}} [\text{k}\Omega] = \frac{12 \text{ V}}{I_{\text{AN}} [\text{mA}]}$$

I_{AN} = Output circuit full-scale value

DC voltage:

Standard ranges
0...10 V, 2...10 V, ± 10 V

Limit values

0...1 to 0...10 V
0.2...1 to 2...10 V
-1...0...+ 1 to -10...0...+ 10 V

Burden:

$$R_{\text{ext min.}} [\text{k}\Omega] \geq \frac{U_{\text{AN}} [\text{V}]}{5 \text{ mA}}$$

U_{AN} = Output circuit full-scale value

Current limiter at

$R_{\text{ext max.}}$:

Approx. $1.1 \times I_{\text{AN}}$ for current output

Voltage limiter at

$R_{\text{ext}} = \infty$:

Approx. 13 V

Residual ripple in

output current:

< 0.5% p.p.

Response time:

< 50 ms

Power supply H →

AC/DC power pack (DC and 45...400 Hz)

Table 3: Nominal voltages and tolerances

Nominal voltage U_N	Tolerance
24 ... 60 V DC / AC	DC - 15 ... + 33%
85 ... 230 V ¹ DC / AC	AC ± 15%

Power input:

≤ 1.6 W resp. ≤ 3.4 VA

Accuracy data (acc. to DIN/IEC 770)

Basic accuracy:

Limit error ≤ ± 0.2%
Including linearity and reproducibility errors

Reference conditions:

Ambient temperature

23 °C, ± 2 K

Power supply

24 V DC ± 10% and 230 V AC ± 10%

Output burden

Current: $0.5 \cdot R_{\text{ext max.}}$
Voltage: $2 \cdot R_{\text{ext min.}}$

Influencing factors:

Temperature

< ± 0.1% per 10 K

Burden influence

< ± 0.1% for current output
< ± 0.2% for voltage output
if $R_{\text{ext}} < 2 \cdot R_{\text{ext min.}}$

¹ For power supplies > 125 V, the auxiliary circuit should include an external fuse with a rating ≤ 20 A DC.

Longtime drift	< ± 0.3% / 12 months	Overvoltage category acc. to IEC 664:	III for power supply II for measuring input and measuring output
Switch-on drift	< ± 0.2%		
Common and transverse mode influence	< ± 0.2%	Double insulation:	– Power supply versus all other circuits – Measuring input versus measuring output
Output + or – connected to ground	< ± 0.2%		

Installation data

Housing:	Housing S17 See section "Dimensional drawings" for dimensions	Test voltage:	Power supply versus: – all 3.7 kV, 50 Hz, 1 min. Measuring inputs versus: – measuring outputs 2.3 kV, 50 Hz, 1 min.
Material of housing:	Lexan 940 (polycarbonate) flammability class V-0 acc. to UL 94, self-extinguishing, non-dripping, free of halogen		Measuring input 1 versus: – measuring input 2 2.3 kV, 50 Hz, 1 min.
Montage:	For snapping onto top-hat rail (35 × 15 mm or 35 × 7.5 mm) acc. to EN 50 022 or directly onto a wall or panel using the pull-out screw hole brackets		Measuring output 1 versus: – measuring output 2 2.3 kV, 50 Hz, 1 min.

Environmental conditions

Position of use:	Any	Climatic rating:	Climate class 3Z acc. to VDI/VDE 3540
Terminals:	DIN/VDE 0609 Screw terminals with wire guards, for light PVC wiring and max. 2 × 0.75 mm ² or 1 × 2.5 mm ²	Commissioning temperature:	– 10 to + 55 °C
Permissible vibrations:	2 g acc. to EN 60 068-2-6	Operating temperature:	– 25 to + 55 °C
Shock:	3 × 50 g 3 shocks each in 6 directions acc. to EN 60 068-2-27	Storage temperature:	– 40 to + 70 °C
Weight:	Approx. 0.2 kg	Annual mean relative humidity:	≤ 75%

Electrical insulation: All circuits (measuring inputs / measuring outputs / power supply) are electrically insulated

Regulations

Electromagnetic compatibility:	The standards DIN EN 50 081-2 and DIN EN 50 082-2 are observed
Protection (acc. to IEC 529 resp. EN 60 529):	Housing IP 40 Terminals IP 20
Electrical standards:	Acc. to IEC 1010 resp. EN 61 010
Operating voltages:	< 300 V between all insulated circuits
Contamination level:	2

SINEAX TV 808, 2 channels

Isolating amplifier unipolar/bipolar

Table 4: Ordering informations (see also Table 1 and 2: "Standard versions")

DESCRIPTION	MARKING
1. Mechanical design Housing S17 for rail and wall mounting	808 - 1
2. Number of channels 2) 2 channels	2
3. Version / Power supply 1) Standard, 24 ... 60 V DC/AC 2) Standard, 85 ... 230 V DC/AC	1 2
4. Function 2) 2 inputs, 2 electrically insulated outputs 3) 1 input, 2 electrically insulated outputs	2 3
5. Input signal, input 1 9) Input [V] <input type="text"/> Z) Input [mA] <input type="text"/> Line 9: [V] 0 ... 0.06 to 0 ... 40 also live-zero, start value > 0 to ≤ 50% final value or span 0.06 to 40 V between -40 and 40 V (also bipolar asymmetrical) Line Z: [mA] 0 ... 0.1 to 0 ... 40 also live-zero, start value > 0 to ≤ 50% final value or span 0.1 to 40 mA between -40 and 40 mA (also bipolar asymmetrical)	9 Z
6. Output signal, output 1 9) Output [V] <input type="text"/> Z) Output [mA] <input type="text"/> Line 9: [V] 0 ... 1 to 0 ... 10 0.2 ... 1 to 2 ... 10 -1 ... 0 ... +1 to -10 ... 0 ... +10 Line Z: [mA] 0 ... 1 to 0 ... 20 0.2 ... 1 to 4 ... 20 -1 ... 0 ... +1 to -20 ... 0 ... +20	9 Z
7. Input signal, input 2 0) Without input 2 9) Input [V] <input type="text"/> Z) Input [mA] <input type="text"/> Ranges possibles see input 1	0 9 Z
8. Output signal, output 2 9) Output [V] <input type="text"/> Z) Output [mA] <input type="text"/> Ranges possibles see output 1	9 Z

Possible special versions, e.g. increased climatic rating on inquiry.

Electrical connections

Front

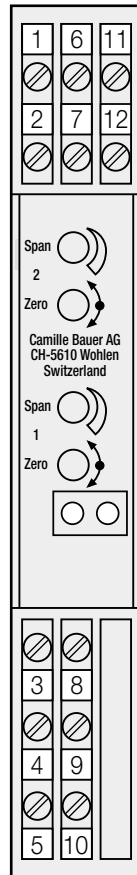

Without transparent cover

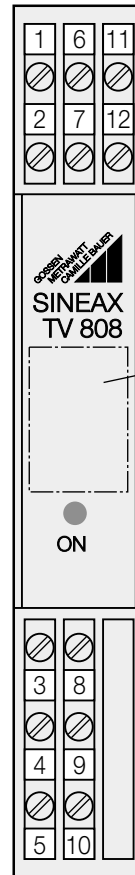

With transparent cover

Space e.g.
for MSK designation

● ON
Green LED for
device standing by

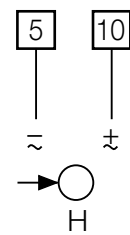
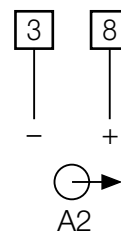
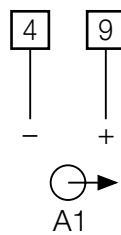
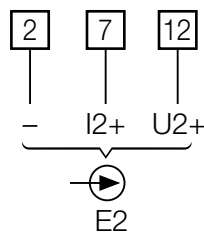
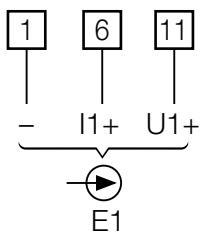

E1 = Input 1
A1 = Output 1
H = Power supply

E2 = Input 2
A2 = Output 2

SINEAX TV 808, 2 channels

Isolating amplifier unipolar/bipolar

Configuration

1. Standard input ranges

Soldered jumpers are provided for the coarse setting of the input ranges and the fine adjustment is accomplished using the potentiometers "Zero" and "Span".

100 must be added to the designations of the soldered jumpers in the table for channel 1 and 200 for channel 2.

(Example: Input range for input 1 and input 2 = 0...20 mA. Jumpers 1, 5, 6 and 11 must be inserted for this range.

- The corresponding jumpers for channel 1 are B 101, B 105, B 106 and B 111.
- The corresponding jumpers for channel 2 are B 201, B 205, B 206 and B 211).

Current [mA]	Soldered jumpers			Voltage [V]		Soldered jumpers	
	1, 3	7, 10, 11				6, 9, 10, 11	
0 ... 0.1	1, 3	7, 10, 11		0 ... 0.06		6, 9, 10, 11	
0 ... 0.2	1, 3	8, 11		0 ... 0.1		7, 8, 10, 11	
0 ... 0.5	1, 4	9, 10, 11		0 ... 0.2		6, 8, 9, 11	
0 ... 1	1, 4	7, 10, 11		0 ... 0.5		6, 7, 8, 9, 10	
0 ... 2	1, 4	8, 11		0 ... 1	2	6, 7, 8, 10, 11	
0 ... 5	1, 5	6, 7, 8, 10, 11		0 ... 2	2	7, 8, 9, 11	
0 ... 10	1, 5	10, 11		0 ... 5	2	8, 10	
0 ... 20	1, 5	6, 11		0 ... 10	1	10, 11	
				0 ... 20	1	6, 11	
				0 ... 40	1	8	
0.2 ... 1	1, 4	8, 10, 11	12, 15	0.2 ... 1	2	9, 10, 11	12, 15
1 ... 5	1, 4	6, 9	12, 15	1 ... 5	2	6, 8, 9, 10	12, 15
2 ... 10	1, 5	6, 7, 10, 11	12, 15	2 ... 10	1	6, 7, 10, 11	12, 15
4 ... 20	1, 5	6, 7, 8, 11	12, 15	4 ... 20	1	6, 7, 8, 11	12, 15
- 0.1 ... 0 ... + 0.1	1, 3	8, 11	13, 14, 16	- 0.1 ... 0 ... + 0.1		6, 8, 9, 11	13, 14, 16
- 0.2 ... 0 ... + 0.2	1, 3	7, 9	13, 14, 16	- 0.2 ... 0 ... + 0.2		6, 7, 9, 10	13, 14, 16
- 0.5 ... 0 ... + 0.5	1, 4	7, 10, 11	13, 14, 16	- 0.5 ... 0 ... + 0.5	2	7, 8, 10, 11	13, 14, 16
- 1 ... 0 ... + 1	1, 4	8, 11	13, 14, 16	- 1 ... 0 ... + 1	2	7, 8, 9, 11	13, 14, 16
- 2 ... 0 ... + 2	1, 4	6, 9	13, 14, 16	- 2 ... 0 ... + 2	2	6, 8, 9, 10	13, 14, 16
- 5 ... 0 ... + 5	1, 5	10, 11	13, 14, 16	- 5 ... 0 ... + 5	1	10, 11	13, 14, 16
- 10 ... 0 ... + 10	1, 5	6, 11	13, 14, 16	- 10 ... 0 ... + 10	1	6, 11	13, 14, 16
- 20 ... 0 ... + 20	1, 5	6, 7	13, 14, 16	- 20 ... 0 ... + 20	1	8	13, 14, 16

2. Standard output ranges

Soldered jumpers are provided for the coarse setting of the output ranges and the fine adjustment is accomplished using the potentiometers "Zero" and "Span".

Current [mA]	Soldered jumpers		Voltage [V]	Soldered jumpers	
	Channel 1	Channel 2		Channel 1	Channel 2
0 ... 20	B 120	B 220	0 ... 10	B 120 B 122 B 123	B 220 B 222 B 223
4 ... 20	B 121	B 221	2 ... 10	B 121 B 122 B 123	B 221 B 222 B 223
± 20	—	—	± 10	B 122 B 123	B 222 B 223

3. Specific user output ranges

Units that have been configured for a specific user output range cannot be subsequently reconfigured.

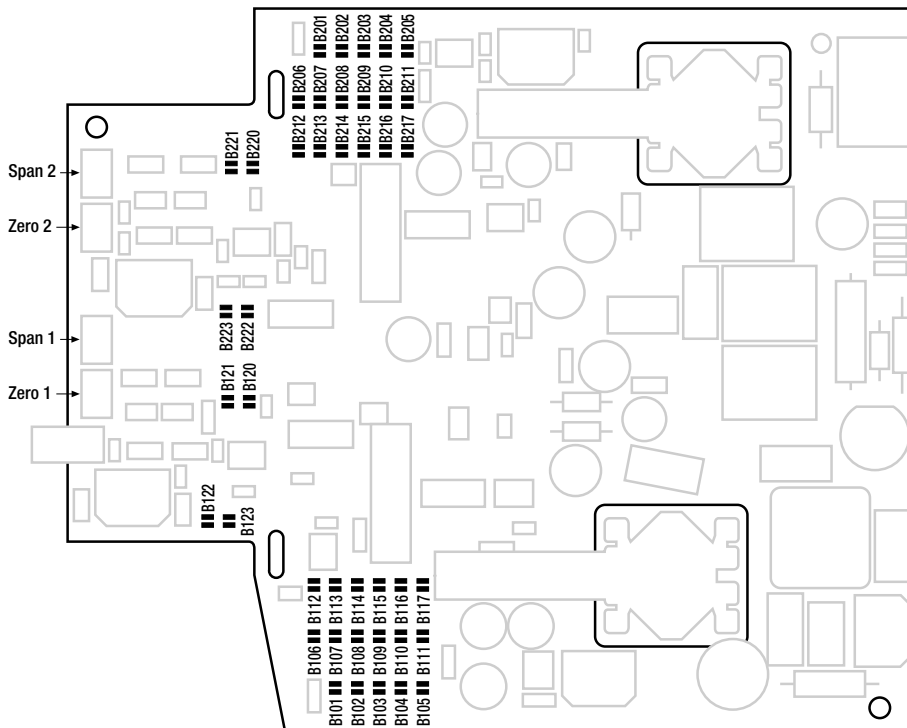

Fig. 2. Position of the soldered jumpers B ... and the potentiometers "Span" and "Zero".

Dimensional drawings

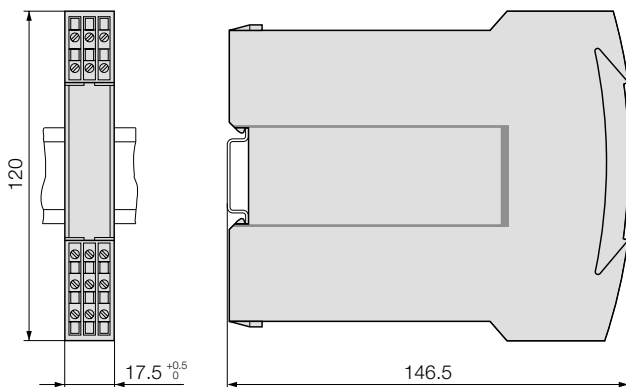

Fig. 3. SINEAX TV 808 in housing **S17** clipped onto a top-hat rail (35x15 mm or 35x7.5 mm, acc. to EN 50 022).

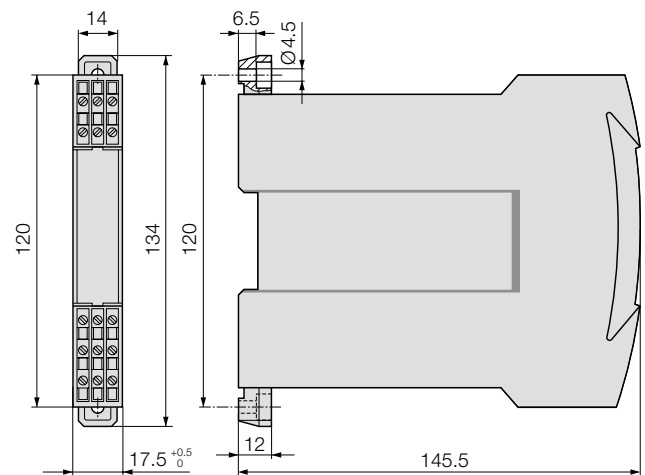

Fig. 4. SINEAX TV 808 in housing **S17**, screw hole mounting brackets pulled out.

Standard accessories

- 1 Operating Instructions in three languages: German, French, English
- 2 Withdrawing handles (for opening the housing)
- 2 Labels (under transparent cover)

SINEAX TV 808, 2 channels

Isolating amplifier unipolar/bipolar

Printed in Germany • Subject to change without notice • Edition 04.99 • Data sheet No. TV 808-12 Le

MOD-TRONIC
INSTRUMENTS LIMITED

48 Haggert Ave N
Brampton, ON L6X 1Y3
Tel: 905 457-6322
Fax: 905 457-4716
Toll Free: 800 794-5883