

# SINEAX U 553

## Transducer for AC voltage

With power supply  
RMS value measurement  
Carrying rail housing P13/70



### Application

The transducer **SINEAX U 553** (Fig. 1) converts a sinusoidal or a distorted AC voltage into a **load independent** DC current or a **load independent** DC voltage proportional to the measured value. The transducer fulfils all the important requirements and regulations concerning electromagnetic compatibility **EMC** and **Safety** (IEC 1010 resp. EN 61 010). It was developed and is manufactured and tested in strict accordance with the **quality assurance standard** ISO 9001.



### Features / Benefits

- **Measuring input: AC voltage, sine or distorted wave forms, true RMS value measurement**

Measured variable	Measuring range limits
AC voltage	0 ... 20 to 0 ... 690 V

- **Measuring output: Unipolar and live-zero output variables**
- **Measuring principle: Logarithmic method**
- **AC/DC power supply / Universal**
- **Standard version as per Germanischer Lloyd**

### Mode of operation

Input signal  $U_{-}$  is galvanically separated from the mains network using a transformer.

The following mathematical expression is then formed using a root-mean-square value computer

$$U_{\text{eff}} = \sqrt{\frac{1}{T} \int_0^T u^2 dt}$$

Fig. 1. Transducer SINEAX U 553 in housing P13/70 clipped onto a top-hat rail.

Following filtration by means of an active filter, the transformation properties of the measuring transducer are determined in the succeeding characteristics circuit.

The output amplifier transforms the measuring signal into an impressed DC current output signal A.

The electronic components are supplied with voltage H from the mains supply unit H.

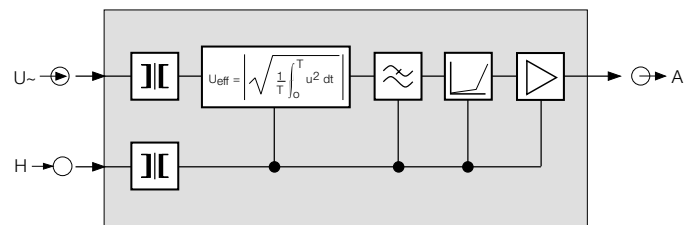

Fig. 2. Block diagram.

### Table 1: Standard versions

The following transducer versions are available as standard versions. It is only necessary to quote the **Order No.:**

Nominal frequency	Measuring range	Output signal	Power supply DC or 40...400 Hz	Setting time	Order No.
50/60 Hz	0 ... 100 V	0 ... 20 mA	85 ... 230 V	300 ms	133 835
	0 ... 100 V	4 ... 20 mA			133 843
	0 ... 120 V	0 ... 20 mA			133 851
	0 ... 120 V	4 ... 20 mA			133 869
	0 ... 250 V	0 ... 20 mA			126 989
	0 ... 250 V	4 ... 20 mA			126 997
	0 ... 500 V	0 ... 20 mA			133 877
	0 ... 500 V	4 ... 20 mA			133 885

The complete order code 553-4... according to "Table 3: Specification and ordering information" must be stated for versions other than the basic version and for special configurations.

# SINEAX U 553

## Transducer for AC voltage

### Technical data

#### General

Measured quantity: AC voltage  
Sine or distorted wave forms  
True RMS value measurement

Measuring principle: Logarithmic method

#### Measuring input E $\rightarrow$

Nominal frequency  $f_N$ : 50/60 or 400 Hz

Nominal input voltage  $U_N$   
(measuring range end value): 0 ... 20 to 0 ... 690 V

Setting: Admissible alteration of full scale output, variable sensitivity, adjustable with potentiometer

Setting range  
 $0.85 \dots 1.15 \cdot U_N (\pm 15\%)$

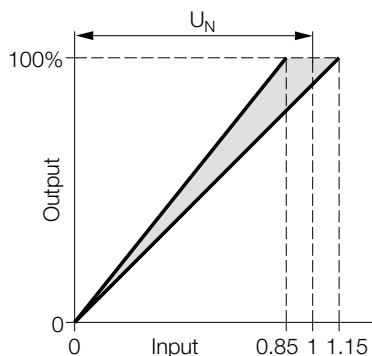

Own consumption:  $\leq 1$  VA with input end value

Overload capacity:

Measured quantity $U_N$	Number of applications	Duration of one application	Interval between two successive applications
$1.2 \cdot U_N^1$	---	continuously	---
$2 \cdot U_N^1$	10	1 s	10 s

<sup>1</sup> But max. 264 V with power supply from measuring input

#### Measuring output A $\rightarrow$

Load-independent DC current: 0...1 to 0...20 mA  
resp. live-zero  
0.2...1 to 4...20 mA

Burden voltage: 15 V

External resistance:  $R_{\text{ext}} \text{ max. } [\text{k}\Omega] = \frac{15 \text{ V}}{I_{\text{AN}} [\text{mA}]}$   
 $I_{\text{AN}} =$  Output current end value

Load-independent DC voltage: 0...1 to 0...10 V  
resp. live-zero  
0.2...1 to 2...10 V

External resistance:  $R_{\text{ext}} [\text{k}\Omega] \geq \frac{U_A [\text{V}]}{2 \text{ mA}}$

Residual ripple in output current:  $\leq 1.5 \cdot I_{\text{AN}}$  at current output  
Approx. 10 mA at voltage output

Voltage limit under  $R_{\text{ext}} = \infty$ :  $\leq 25$  V

Residual ripple in output current:  $\leq 0.5\%$  p.p. at setting time 300 ms  
 $\leq 2\%$  p.p. at setting time 50 ms

Setting time: 50 ms or 300 ms

#### Power supply H $\rightarrow$

AC/DC power pack (DC or 40...400 Hz)

Table 2: Rated voltages and permissible variations

Rated voltage	Tolerance
85 ... 230 V DC / AC	DC - 15 ... + 33%
24 ... 60 V DC / AC	AC $\pm 15\%$

Option: Connected to the low tension terminal side 12 and 13  
24 V AC or 24...60 V DC

Power consumption:  $\leq 1.5$  W resp.  $\leq 3$  VA

#### Accuracy (acc. to DIN/IEC 688)

Reference value: Output end value

Basic accuracy: Class 0.5

#### Reference conditions:

Ambient temperature 15 ... 30 °C

Input variable Rated operating range

Frequency  $f_N \pm 2$  Hz

Curve shape Sine-wave

Crest factor  $\sqrt{2}$

Power supply In rated range

Output burden Current:  $0.5 \cdot R_{\text{ext}} \text{ max.}$   
Voltage:  $2 \cdot R_{\text{ext}} \text{ min.}$

Warm-up time  $\leq 5$  min.

**Influence effects (maxima):**  
included in basic error

Frequency	40 ... 400 Hz,	± 0.3%
	30 ... 1000 Hz,	± 0.5%
Crest factor	1 ... 2.5	± 0.2%
	> 2.5 ... 6	± 0.5%

**Safety**

Protection class:	II (protection isolated, DIN EN 61 010)
Housing protection:	IP 40, housing (test wire, EN 60 529) IP 20, terminals (test finger, EN 60 529)
Contamination level:	2
Overvoltage category:	III
Rated insulation voltage (versus earth):	400 V, input 230 V, power supply 40 V, output
Test voltage:	50 Hz, 1 min. acc. to DIN EN 61 010-1 3700 resp. 5550 V, input versus all other circuits as well as outer surface 3700 V, power supply versus output as well as outer surface 490 V, output versus outer surface

**Installation data**

Mechanical design:	Housing <b>P13/70</b>
Material of housing:	Lexan 940 (polycarbonate), flammability Class V-0 acc. to UL 94, self-extinguishing, non-dripping, free of halogen
Mounting:	For rail mounting
Mounting position:	Any
Weight:	Approx. 0.3 kg

**Connecting terminals**

Connection element:	Screw-type terminals with indirect wire pressure
Permissible cross section of the connection leads:	≤ 4.0 mm <sup>2</sup> single wire or 2 × 2.5 mm <sup>2</sup> fine wire

**Environmental conditions**

Climatic rating:	Climate class 3 acc. to VDI/VDE 3540
Operating temperature:	- 10 to + 55 °C
Storage temperature:	- 40 to +70 °C
Relative humidity of annual mean:	≤ 75%

**Vibration withstand**

(tested according to DIN EN 60 068-2-6)	
Acceleration:	± 2 g
Frequency range:	10 ... 150 ... 10 Hz, rate of frequency sweep: 1 octave / minute
Number of cycles:	10 in each of the three axes
Result:	No faults occurred, no loss of accu- racy and no problems with the snap fastener

**Germanischer Lloyd**

Type approval certificate:	No. 12 259-98 HH
Ambient category:	C
Vibration:	0.7 g

**Table 3: Specification and ordering information** (see also Table 1: Standard versions)

Order Code <b>553</b> -			
Features, Selection	*SCODE	no-go	
<b>1. Mechanical design</b>			
4) Housing P13/70 for rail mounting			
<b>2. Nominal input frequency</b>			
1) 50/60 Hz			
3) 400 Hz			

Continuation see on next page!

# SINEAX U 553

## Transducer for AC voltage

Continuation of Table 3: "Specification and ordering information"

Order Code 553 -			
Features, Selection	*SCODE	no-go	
<b>3. Measuring range</b>			
A) 0 ... 100 / $\sqrt{3}$	A		A . . . . .
B) 0 ... 110 / $\sqrt{3}$	A		B . . . . .
C) 0 ... 100	B		C . . . . .
D) 0 ... 110	B		D . . . . .
E) 0 ... 116.66	B		E . . . . .
F) 0 ... 120	B		F . . . . .
G) 0 ... 125	B		G . . . . .
H) 0 ... 133.33	B		H . . . . .
J) 0 ... 150	B		J . . . . .
K) 0 ... 250	B		K . . . . .
L) 0 ... 500*	C		L . . . . .
Z) Non-standard 0 ... 20 to 0 ... 690* With power supply from measuring input min. 24 V / max. 230 V, see feature 5, lines 3 and 4  * Max. 400 V nominal value of the network against earth (operating voltage acc. to EN 61 010)			Z . . . . .
<b>4. Output signal</b>			
1) 0 ... 20 mA, $R_{ext} \leq 750 \Omega$			. 1 . . . . .
2) 4 ... 20 mA, $R_{ext} \leq 750 \Omega$			. 2 . . . . .
9) Non-standard 0 ... 1.00 to 0 ... < 20 0.2 ... 1 to < (4 ... 20)	[mA]		. 9 . . . . .
A) 0 ... 10 V, $R_{ext} \geq 5 k\Omega$			. A . . . . .
Z) Non-standard 0 ... 1.00 to 0 ... < 10 0.2 ... 1 to 2 ... 10	[V]		. Z . . . . .
<b>5. Power supply</b>			
1) 85 ... 230 V DC / AC			. . 1 . . . . .
2) 24 ... 60 V DC / AC			. . 2 . . . . .
3) From measuring input $\geq 24$ ... 60 V AC		BC	. . 3 . . . . .
4) From measuring input $\geq 85$ ... 230 V AC		AC	. . 4 . . . . .
5) Connected to the low tension terminal side 12 and 13 24 V AC / 24 ... 60 V DC			. . 5 . . . . .
<b>6. Setting time</b>			
1) 0.3 s			. . . 1 . . . . .
2) 50 ms			. . . 2 . . . . .

\* Lines with letter(s) under "no-go" cannot be combined with preceding lines having the same letter under "SCODE".

## Electrical connections

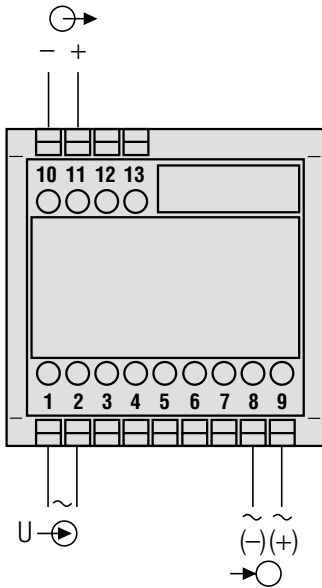

Fig. 3. Power supply connected to terminals 8 and 9.

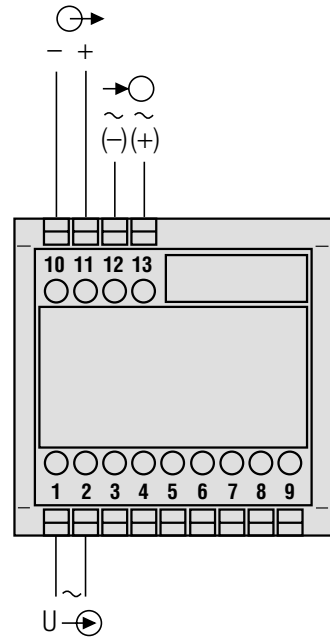

Fig. 5. Power supply connected to the low tension terminal side 12 and 13.

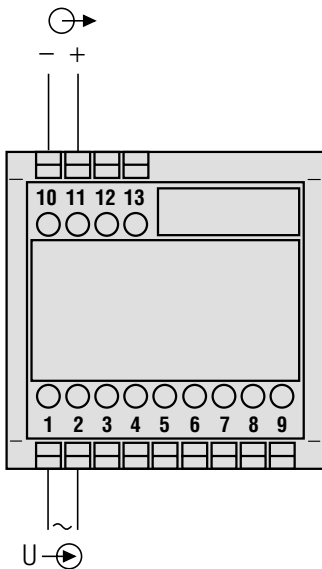

Fig. 4. Power supply internal from measuring input, without separated power supply connected.

- = Measuring input
- = Measuring output
- = Power supply

# SINEAX U 553

## Transducer for AC voltage

### Dimensional drawing

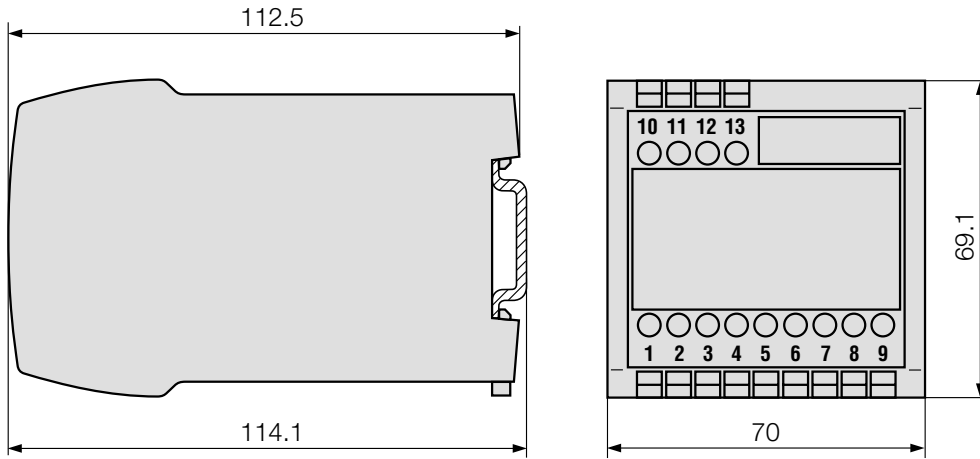

Fig. 6. SINEAX U 553 in housing **P13/70** clipped onto a top-hat rail (35 × 15 mm or 35 × 7.5 mm, acc. to EN 50 022).

### Standard accessories

1 Operating Instructions in three languages: German, French, English



# **SINEAX U 553**

## **Transducer for AC voltage**

---

---

Printed in Switzerland • Subject to change without notice • Edition 03.99 • Data sheet No. U 553 Le

**MOD-TRONIC**  
INSTRUMENTS LIMITED

48 Haggert Ave N  
Brampton, ON L6X 1Y3  
Tel: 905 457-6322  
Fax: 905 457-4716  
Toll Free: 800 794-5883