

SINEAX VK 626

Programmable Temperature Transmitter for RTD and TC inputs, with HART protocol

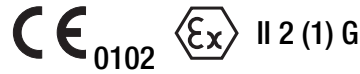

for installation in the terminal head of a temperature sensor DIN 43 729, Shape B



Application

SINEAX VK 626 is a two-wire head-mounted transmitter. It is designed for **measuring temperature in combination with thermocouples or resistance thermometers**. Thermocouple non-linearities are automatically compensated. The output signal is a current in the range 4...20 mA.

Measured variable and measuring range are programmed using a PC with a suitable interface and running the programming software.

The sensor circuit is monitored for open and short-circuits and the output responds in a defined manner if one is detected.

The power supply of (12...30 V DC) is connected together with the signal by the two leads connected to the measurement output (loop powered).



Fig. 1. Measuring transmitter SINEAX VK 626 – 7A/7B, input/output electrically isolated.

Features / Benefits

- Two-wire programming (HART protocol) of measured variable and measuring range

Measured variables	Measuring ranges		
	Limits	Min. span	Max. span
Temperatures with resistance thermometers for two-, three- or four-wire connection			
Pt 100, IEC 60 751	- 200 to 850 °C	50 K	850 K
Ni 100, DIN 43 760	- 60 to 250 °C	50 K	250 K
Temperatures with thermocouples			
Type B, E, J, K, N, R, S, T acc. to IEC 60 584-1	acc. to type	2 mV	80 mV
Type L and U, DIN 43 710			
Type W5 Re/W26 Re, Type W3 Re/W25 Re acc. to ASTM E 988-90			

- Electrical isolation between input and output / Prevents measurement errors due to potential leakage
- Open and short-circuit sensor circuit supervision / Defined output response should the supervision pick up
- Terminals with captive screws
- Available in type of protection "Intrinsic safety" EEx ia IIC T6 (see "Table 3: Data on explosion protection")

Basic configuration:	Measuring input	Pt 100 for three-wire connection
	Measuring range	0 ... 600 °C
	Measuring output	4 ... 20 mA, linearised with temperature
	Open-circuit supervision	Output 21.6 mA
	Response time	Approx. 1.5/2 s (Table 2)
	Mains ripple suppression	For frequency 50 Hz

Standard versions

The following versions are available ex stock already programmed for the **basic** configuration. It is only necessary to quote the **Order No.:**

Table 1:

Version	Dimensions Ø 43 mm	Order Code	Order No.
Standard, electrically isolated	Height 30.8 mm	626 - 7A0	141 424
EEx ia IIC T6, electrically isolated	Height 30.8 mm	626 - 7B0	141 432

Please complete the Order Code 626-7.1. according to "Table 4: Specification and ordering information" for versions with user-specific input ranges.

SINEAX VK 626

Programmable Temperature Transmitter

for RTD and TC inputs, with HART protocol

Programming

The SINEAX VK 626 is configured via a 4...20 mA two-wire lead using the HART protocol.

Programming is accomplished using a PC with a suitable interface (e.g. Smar HI 311, MACTeck Viator 010001, Siemens 7MF 4997-1DA) and running the programming software.

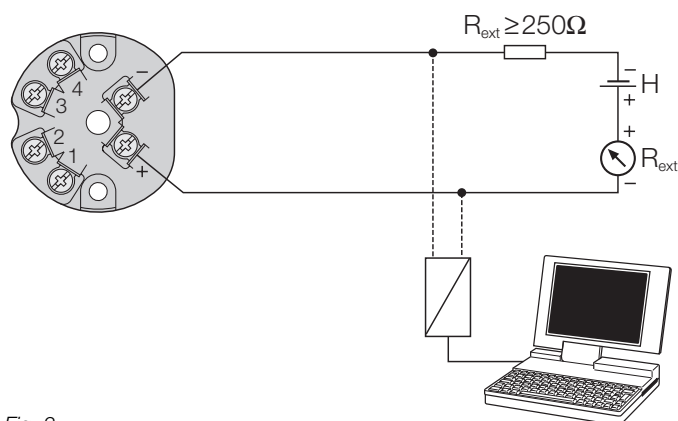

Fig. 2

Technical data

Measuring input

Temperature with resistance thermometers

- Measuring range limits: See Table 5
- Resistance types: Type Pt 100 (IEC 60 751)
Type Ni 100 (DIN 43 760)
Other sensor types configurables
- Measuring current: ≤ 0.20 mA
- Standard circuit: 1 resistance thermometer for **two-, three- or four-wire** connection
- Input resistance: $R_i > 10$ M Ω
- Lead resistance: ≤ 30 Ω per lead

Temperature with thermocouple

- Measuring range limits: See Table 5
- Thermocouple pairs: Type B: Pt30Rh-Pt6Rh (IEC 584)
Type E: NiCr-CuNi (IEC 584)
Type J: Fe-CuNi (IEC 584)
Type K: NiCr-Ni (IEC 584)
Type L: Fe-CuNi (DIN 43710)
Type N: NiCrSi-NiSi (IEC 584)
Type R: Pt13Rh-Pt (IEC 584)
Type S: Pt10Rh-Pt (IEC 584)
Type T: Cu-CuNi (IEC 584)
Type U: Cu-CuNi (DIN 43710)
Type W5 Re/W26 Re (ASTM)
Type W3 Re/W25 Re (E 988-90)

¹⁾ Note FSK Physical Layer Specifications!

- Standard circuit: 1 thermocouple, **internal** cold junction compensation with built-in Pt 100 or
1 thermocouple, **external** cold junction compensation
- Input resistance: $R_i > 10$ M Ω

Cold junction compensation

- Internal: With built-in Pt 100 or with Pt 100 connected to the terminals
- External: Via cold junction thermostat 0 ... 60 °C, configurable

Measuring output

- Output signal I_A : Impressed DC current, **linear with temperature**
- Standard range: 4...20 mA, 2-wire technique
- External resistance¹⁾ (load): $R_{ext \max} = \frac{\text{Power supply [V]} - 12 \text{ V}}{\text{Max. output current [mA]}}$

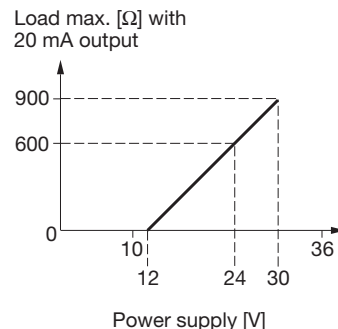

- Residual ripple in output current: $< 1\%$ p.p.

Table 2: Response time

Measuring mode	Open sensor circuit	Short-circuit	Possible response times approx. [s]							
			Option							
TC int. comp.	active	–	1.5	2.5	3.5	6.5	11	20.5	40	
TC int. comp.	off	–	1.5	2.5	3.5	6.5	13.5	24.5	49.5	
TC ext. comp.	active	–	1.5	2.5	3.5	6.5	11	20.5	40	
TC ext. comp.	off	–	1.5	2.5	4	6.5	13.5	24.5	48.5	
RTD 2L	active	–	2	2.5	3	5	9.5	17.5	33.5	
RTD 3L, 4L	active	active	2	2.5	4	6.5	11.5	21	40.5	
RTD 2L,3L,4L	off	off	1.5	2.5	3.5	7.5	14	26.5	50.5	

^{*)} Standard values, also valid for basic configuration

Accuracy data (acc. to EN/IEC 60 770-1)

- Reference value: Measuring span
- Basic accuracy: Error limits $\leq \pm 0.2\%$ at reference conditions

Reference conditions

Ambient temperature	23 °C
Power supply	18 V DC
Output burden	250 Ω
Settings	Pt100, 3-wire, 0...600 °C

Additional errors (additive)

Low measuring ranges	
Voltage measurement	± 5 µV at measuring spans < 10 mV
Resistance thermometer	± 0.3 K at measuring spans < 400 °C
Thermocouple	
Type U, T, L, J, K, E	± 0.1 K at measuring spans < 200 °C
Type N	± 0.13 K at measuring spans < 320 °C
Type S, R	± 0.42 K at measuring spans < 1000 °C
Type B	± 0.6 K at measuring spans < 1400 °C
High initial value	(Additional error = factor · initial value)
Factor	
Voltage measurement	± 0.1 µV / mV
Resistance thermometer	± 0.00075 K / °C
Thermocouple	
Type U, T, L, J, K, E	± 0.0006 K / °C
Type N	± 0.0008 K / °C
Type S, R	± 0.0025 K / °C
Type B	± 0.0036 K / °C
Influence of lead resistance at resistance thermometer	± 0.01% per Ω
Internal cold junction compensation	± 0.5 K
Linearisation	± 0.3%

Influencing factors

Temperature	≤ ± (0.15% + 0.15 K) per 10 K with temperature measurement ≤ ± (0.15% + 12 µV) per 10 K with voltage measurement
Power supply influence (power supply on terminals)	≤ ± 0.005% per V
Long-time drift	≤ ± 0.1%
Common and transverse mode influence	≤ ± 0.2%

Open and short-circuit sensor circuit supervision

Signalling modes:	Output signal programmable to the value the output had immediately prior to the open or short-circuit (hold value) ... a value between 4 and 21.6 mA
-------------------	--

Power supply →○

DC voltage:	Supply 12...30 V DC max. residual ripple 1% p.p. ¹⁾ (supply must not fall below 12 V) Protected against wrong polarity
-------------	---

HART communication

HART protocols:	Revision 5.10
-----------------	---------------

Installation data

Dimensions:	See section "Dimensional drawing"
Housing:	Lexan 940 (polycarbonate) Flammability class V-0 acc. to UL 94, self-extinguishing, non-dripping, free of halogen
Mounting position:	Any
Electrical connections:	Screw terminals with Philips heads for max. 2 × 1.5 mm ²
Weight:	Approx. 60 g
Mounting:	Shape B version of terminal head held by two M4 cheese-headed screws and two springs

Standards

Electromagnetic compatibility:	The standards DIN EN 50 081-2 and DIN EN 50 082-2 are observed
Intrinsically safe:	Acc. to EN 50 020
Protection (acc. to IEC 529 resp. EN 60 529):	Housing IP 40 Terminals IP 00
Electrical standards:	Acc. to IEC 1010 resp. EN 61 010
Test voltage:	1500 V AC, applied between measuring input and output

Ambient conditions

Climatic rating:	IEC 60 068-2-1/2/3
Ambient temperature range:	-25 to +80 °C at NEx and Ex (T4) at Ex (T6) dependent of P _i , see EC-type-examination Certificate
Storage temperature range:	-40 to +80 °C
Annual mean relative humidity:	≤ 75%, no moisture condensation

¹⁾ Note HART FSK Physical Layer Specifications!

SINEAX VK 626

Programmable Temperature Transmitter

for RTD and TC inputs, with HART protocol

Table 3: Data on explosion protection  **II 2 (1) G**

Order Code	Type of protection Marking	Electrical data acc. to Certificate Sensor input	Output	Certificate	Mounting location of instrument
626 - 7B	EEx ia IIC T6	$U_o = 6\text{ V}$ $I_o = 5\text{ mA}$ $P_o = 11\text{ mW}$ $C_o = 1864\text{ nF}$ $L_o = 5\text{ mH}$	$U_i = 30\text{ V}$ $I_i = 160\text{ mA}$ $P_i = \text{max. } 1\text{ W}^*$ $C_i \approx 0$ $L_i \approx 0$	EC-type-examination Certificate ZELM 01 ATEX 0067	Within the hazardous area, zone 1 and 2**

* According to temperature class

** It is permissible for the sensor circuit to enter Zone 0, however, EN 50 284 and any applicable national standards must be observed.

Table 4: Specification and ordering information (see also Table 1: Standard versions)



Order Code 626 -			
Features, Selection	*SCODE	no-go	
1. Housing (power supply via output leads) 7) For installation in a terminal head DIN 43 729, shape B			7
2. Version A) Not intrinsically safe B) EEx ia IIC T6, intrinsically safe electrical circuits			. A B
3. Configuration 0) Basic configuration programmed (Pt 100, 3-wire, 0...600 °C) 1) Programmed to order Line 0: All types with basic configuration are available as standard versions, see table 1, specification complete! Line 1: The following features 4 to 11 must be fully specified.	G		. . 0 1
4. Measuring unit 1) Temperatures in °C 2) Temperatures in °F 3) Temperatures in K		G	. . . 1 2 3
5. Measuring mode, input connection Thermocouple 1) Internal cold junction compensation, with built-in Pt 100 2) External cold junction compensation t_k 	T	G 1 2
Resistance thermometer 3) Two-wire connection, R_L  [Ω] 4) Three-wire connection, $R_L \leq 30\text{ }\Omega/\text{wire}$ 5) Four-wire connection, $R_L \leq 30\text{ }\Omega/\text{wire}$	R	G 3 4 5
Line 2: Specify external cold junction temperature in t_k (in °C, °F or K, acc. to specification in Feature 4), any value between 0 and 60 °C or equivalent Line 3: Specify total lead resistance R_L [Ω], any value between 0 and 60 Ω			

Table 4: "Specification and ordering information" continued on next page!

Order Code 626 -					
Features, Selection			*SCODE	no-go	
6. Sensor type / measuring range					
Sensor type / beginning...end value of measuring range					
1) RTD Pt 100	Range			T	
2) RTD Ni 100	Range			GT	
3) RTD Pt ... [Ω]	Range			GT	
4) RTD Ni ... [Ω]	Range			GT	
B) TC Type B	Range			GR	
E) TC Type E	Range			GR	
J) TC Type J	Range			GR	
K) TC Type K	Range			GR	
L) TC Type L	Range			GR	
N) TC Type N	Range			GR	
R) TC Type R	Range			GR	
S) TC Type S	Range			GR	
T) TC Type T	Range			GR	
U) TC Type U	Range			GR	
W) TC W5-W26Re	Range			GR	
X) TC W3-W25Re	Range			GR	
Specify measuring range in [$^{\circ}$ C], [$^{\circ}$ F] or [K]; refer to table 5 for the operating limits for each type of sensor.					
Lines 3 and 4: Specify resistance in Ω at 0 $^{\circ}$ C, any value between 50 and 4000 Ω					
7. Output characteristic					
0) Standard 4 ... 20 mA					
1) Inversely 20 ... 4 mA				G	
8. Open and short-circuit sensor signalling					
Output response for an open or short-circuit* sensor					
0) Output 21.6 mA					
1) Output	[mA]			G	
2) Hold output at last value				G	
A) No signal				G	
Line 1: Any value between 4 and < 21.6 mA					
* The short-circuit signal is only active for the RTD measuring mode $\geq 100 \Omega$ at 0 $^{\circ}$ C and three or four-wire connection.					
9. Output time response					
0) Standard setting time approx. 2 s					
9) Setting time	[s]			G	
Line 9: Admissible values see Table 2					
10. Mains ripple suppression					
0) Frequency 50 Hz					
1) Frequency 60 Hz				G	
11. Test certificate					
0) Without test certificate					
D) Test certificate in German				G	
E) Test certificate in English				G	

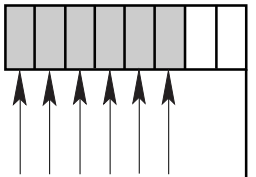

1
2
3
4
B
E
J
K
L
N
R
S
T
U
W
X

. 0
. 1

. . 0
. . 1
. . 2
. . A

. . . 0
. . . 9

. . . . 0
. . . . 1

. 0
. D
. E

* Lines with letter(s) under "no-go" cannot be combined with preceding lines having the same letter under "SCODE".

SINEAX VK 626

Programmable Temperature Transmitter for RTD and TC inputs, with HART protocol

Table 5: Temperature measuring ranges

Measuring ranges [°C]	Resistance thermometers		Thermocouples											
	Pt100	Ni100	B	E	J	K	L	N	R	S	T	U	C ¹⁾	D ²⁾
0... 40	X			X	X		X							
0... 50	X	X		X	X	X	X				X	X		
0... 60	X	X		X	X	X	X				X	X		
0... 80	X	X		X	X	X	X	X			X	X		
0... 100	X	X		X	X	X	X	X			X	X		
0... 120	X	X		X	X	X	X	X			X	X		
0... 150	X	X		X	X	X	X	X			X	X	X	
0... 200	X	X		X	X	X	X	X			X	X	X	X
0... 250	X	X		X	X	X	X	X			X	X	X	X
0... 300	X			X	X	X	X	X	X	X	X	X	X	X
0... 400	X			X	X	X	X	X	X	X	X	X	X	X
0... 500	X			X	X	X	X	X	X	X		X	X	X
0... 600	X			X	X	X	X	X	X	X		X	X	X
0... 800	X		X	X	X	X	X	X	X	X			X	X
0... 900			X	X	X	X	X	X	X	X			X	X
0...1000			X	X	X	X		X	X	X			X	X
0...1200			X		X	X		X	X	X			X	X
0...1500			X						X	X			X	X
0...1600			X						X	X			X	X
0...1800			X										X	X
0...2000													X	X
50... 150	X	X		X	X	X	X	X			X	X		
100... 300	X			X	X	X	X	X			X	X	X	X
200... 500	X			X	X	X	X	X	X	X		X	X	X
300... 600	X			X	X	X	X	X	X	X		X	X	X
600... 900			X	X	X	X	X	X	X	X			X	X
600...1000			X	X	X	X		X	X	X			X	X
900...1200			X		X	X		X	X	X			X	X
600...1600			X						X	X			X	X
600...1800			X										X	X
-10... 40	X	X		X	X	X	X					X		
-30... 60	X	X		X	X	X	X	X			X	X		
Measuring range limits [°C]	-200 to 850	-60 to 250	0 to 1820	-270 to 1000	-210 to 1200	-270 to 1372	-200 to 900	-270 to 1300	-50 to 1769	-50 to 1769	-270 to 400	-200 to 600	0 to 2315	0 to 2315
	ΔR min. 15 Ω at final value ³⁾ $\leq 400 \Omega$ ΔR min. 150 Ω at final value $> 400 \Omega$ max. final value 4000 Ω $\frac{\text{Initial value}}{\Delta R} \leq 10$		ΔU min 2 mV, max. 80 mV $\frac{\text{Initial value}}{\Delta U} \leq 10$											

¹⁾ W5 Re W26 Re (ASTM E 988-90)

²⁾ W3 Re W25 Re (ASTM E 988-90)

³⁾ For two-wire connection, the final value is made up of the measured final value [Ω] plus the total resistance of the leads.

Electrical connections

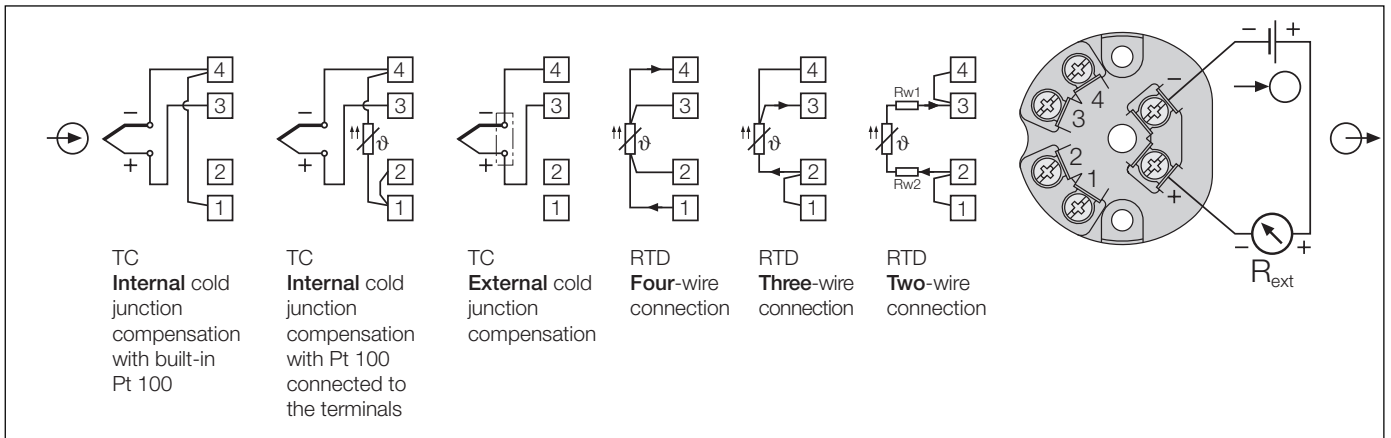

⊖ = Measuring input

⊕ = Two-wire measuring output (measuring circuit)
(4 ... 20 mA signal)

→ ⊖ = Power supply 12 ... 30 V DC

Table 6: Accessories

Description	Order No.
Configuration Software V 600 plus for SINEAX VK 616, VK 626, V 608 and V 624 Windows 3.1x, 95, 98, NT and 2000 on CD in German, English, French, Spanish, Italian and Dutch. (Download free of charge under http://www.gmc-instruments.com)	146 557
Operating Instructions VK 626 Bd in German	141 961
Operating Instructions VK 626 Bf in French	142 084
Operating Instructions VK 626 Be in English	142 133

Standard accessories

- 1 Operating Instructions in German, French and English
- 1 Type examination certificate (only for "intrinsically safe" explosion-proof devices)

Dimensional drawing

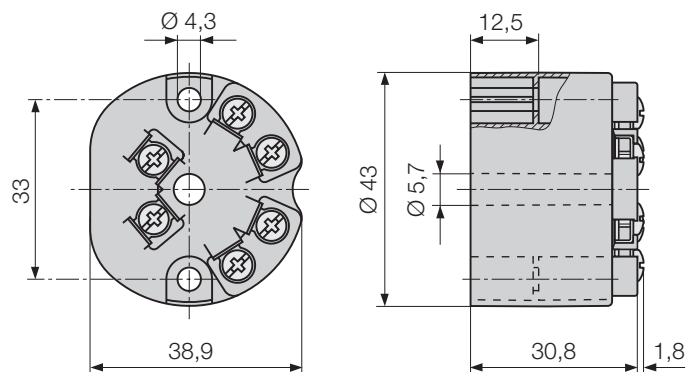

Fig. 3. SINEAX VK 626.

SINEAX VK 626

Programmable Temperature Transmitter for RTD and TC inputs, with HART protocol

Printed in Switzerland • Subject to change without notice • Edition 09.01 • Data sheet No. VK 626 Le

MOD-TRONIC
INSTRUMENTS LIMITED

48 Haggert Ave N
Brampton, ON L6X 1Y3
Tel: 905 457-6322
Fax: 905 457-4716
Toll Free: 800 794-5883