

Safety precautions to be strictly observed are marked with following symbols in the Operating Instructions:



Operating Instructions Programmable Temperature Transmitter SINEAX VK 626



VK 626 Be 142 133 10.01

GOSSEN
METRAWATT
CAMILLE BAUER

Mod-Tronic Instruments Limited Tel: 1 800 794-5883 Fax: 1 800 830-7122 www.mod-tronic.com



Contents

1. Read first and then	1
2. Scope of supply	1
3. Brief description	1
4. Technical data	2
5. Securing the terminal head of the temperature sensor	2
6. Installation in the plant	2
7. Electrical connections	2
8. Configuring the transmitter	3
9. Commissioning	4
10. Maintenance	4
11. Accessories and spare parts	4
12. Dimensional drawing	4

1. Read first and then ...



The proper and safe operation of the device assumes that the Operating Instructions are **read** and the safety warnings given in the various Sections

- 6. Installation in the plant
- 7. Electrical connections
- 8. Configuring the transmitter
- 9. Commissioning

are **observed**.

The device should only be handled by appropriately trained personnel who are familiar with it and authorised to work in electrical installations.

2. Scope of supply (Figs. 1 and 2)

Transmitter (1)

Order Code: Significance of the 2nd and 3rd digits

626 - 7 x x	
A	Not intrinsically safe
B	EEx ia IIC T6, intrinsically safe electrical circuits
0	Basic configuration programmed
1	Configured to order



Fig. 1

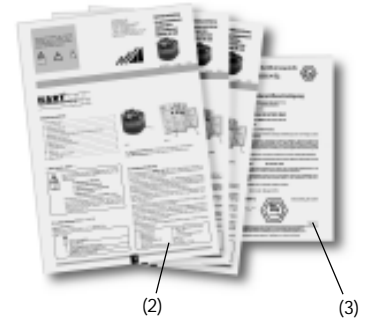

Fig. 2

1 Operating Instructions (2) each in German, French and English
1 Type Examination Certificate (3), only for "intrinsically safe" explosion-proof devices

3. Brief description

The programmable **SINEAX VK 626** is a two-wire head-mounted transmitter. It is designed for installation in the terminal head of a temperature sensor DIN 43 729, shape B.

It is used for measuring temperature in conjunction with a thermocouple or resistance thermometer. Thermocouple non-linearities are automatically compensated. The output signal is a current in the range 4...20 mA.

The input, measuring range, signalling and other parameters are programmed with the aid of a HART Interface, a PC and the corresponding software.

The sensor circuit is monitored for open and short-circuits and the output responds in a defined manner if one is detected.

The power supply of (12...30 V DC) is connected together with the signal by the two leads connected to the measurement output (loop powered).

Explosion-proof "intrinsically safe" EEx ia IIC T6 versions rounds off the series of transmitters.

Transmitters supplied as standard versions are configured as follows:

- Measuring input:	Pt 100 for three-wire connection
- Measuring range:	0 ... 600 °C
- Measuring output:	4 ... 20 mA, linearised with temperature
- Open-circuit supervision:	Output 21.6 mA
- Response time:	Approx. 1.5/2 s
- Mains ripple suppression:	For frequency 50 Hz

4. Technical data

Measuring input

Input variable and measuring range configured

Input variables	Measuring ranges		
	Limits	Min. span	Max. span
Temperatures with resistance thermometers for two, three or four-wire connection			
Pt 100, IEC 60 751	- 200 to 850 °C	50 K	850 K
Ni 100, DIN 43 760	- 60 to 250 °C	50 K	250 K
Temperatures with thermocouples			
Type B, E, J, K, N, R, S, T acc. to IEC 60 584-1	acc. to type	2 mV	80 mV
Type L and U, DIN 43 710			
Type W5 Re/W26 Re, Type W3 Re/W25 Re acc. to ASTM E 988-90			

Cold junction compensation

Internal: Incorporated Pt 100 or with Pt 100 connected to the terminals

External: Via cold junction thermometer 0...60 °C, configurable

Measuring output

(output/powering circuit)
Output signal IA: Impressed DC current, **linear with temperature**

Standard range: 4...20 mA, 2-wire technique

External resistance¹⁾ (load): $R_{ext} \max. = \frac{\text{Power supply [V]} - 12 \text{ V}}{[\text{k}\Omega]} = \frac{\text{Max. output current [mA]}}{}$

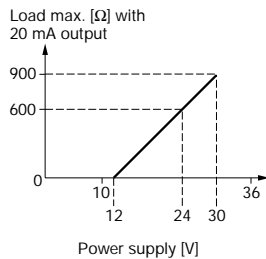

Open and short-circuit sensor circuit supervision

Signalling modes: Output signal configurable to ...
... the value the output had immediately prior to the open or short-circuit* (hold value)
... a value between 4 and 21.6 mA

* The short-circuit indicator is only active for the RTD $\geq 100 \Omega$ at 0 °C, three and four-wire measuring mode

Power supply

DC voltage: Supply 12 ... 30 V DC
max. residual ripple 1% p.p.¹⁾
(supply must not fall below 12 V)
Protected against wrong polarity

HART communication

HART protocol: Revision 5.10

¹⁾ Note HART FSK Physical Layer Specifications!

5. Securing the terminal head of the temperature sensor

The **SINEAX VK 626** is suitable for mounting on an insert that is fitted into a temperature sensor with a Shape B DIN terminal head.

The length of the leads to the insert has to conform to the height of the terminal head (Fig. 4).

Thread the leads through the hole in the centre of the transmitter. Align the transmitter in the lower part of the terminal head and secure it using two cheese-headed screws (1) and two springs (2) (see Fig. 3). Connect the leads acc. to section "7. Electrical connections".

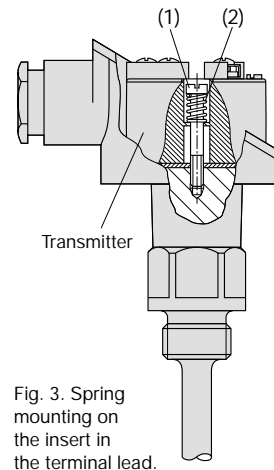

Fig. 3. Spring mounting on the insert in the terminal lead.

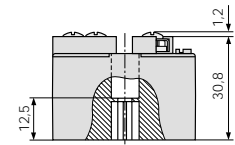

Fig. 4.

6. Installation in the plant

Mount the thermometer transmitter according type (screwed, sliding terminal screws, flange etc.) at the prescribed location.



Make sure that the ambient temperature stays within the **permissible limits**:

Standard instruments: - 25 and + 80 °C

Ex version: - 25 to max. 52 °C

(depending on P_{tr}, see type examination certificate)!

7. Electrical connections

The leads are connected to the 6 Phillips head screw terminals on the front of the transmitter. The maximum wire gauge is 2 x 1.5 mm², see Fig. 5. The applicable enclosure Protection Class for the terminals is IP 00 according to EN 60 529.

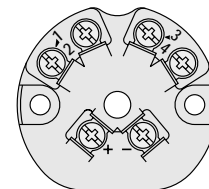

Fig. 5



Also note that, ...

... the data required to carry out the prescribed measurement must correspond to those marked on the nameplate of SINEAX VK 626 (Sensor, Range, Output, Supply Voltage)!

... the total loop resistance connected to the output (receiver plus leads) **does not** exceed the maximum permissible value R_{ext}, see "Measuring output" in Section "4. Technical data"!

... the measurement input and output cables should be twisted pairs and run as far as possible away from heavy current cables!

In all other respects, observe all local regulations when selecting the type of electrical cable and installing them!



In the case of "Intrinsically safe" explosion-proof, the supplementary information given on the type examination certification, the EN 60 079-14, and also local regulations applicable to electrical installation in explosion hazard areas must be taken into account!

7.1 Alternative measurement connections

Connect the measuring leads to suit the application as given in Table 1.

Table 1: Measuring input

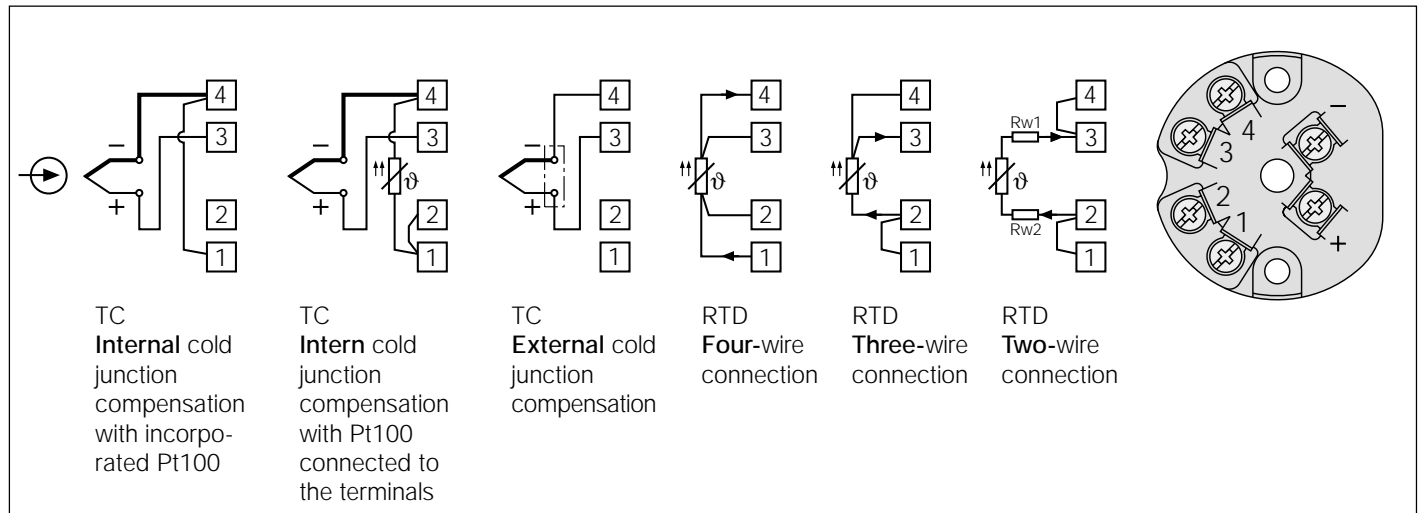

Note:

7.1.1 Connection to thermocouples

Pay attention to correct polarity when connecting thermocouples. If the lead from the thermocouple to the transmitter has to be extended, be sure to use thermally compensated leads suitable for the particular type of thermocouple.

7.1.1.1 Internal, cold junction compensation with incorporated Pt100
Connect terminals ① and ④ when using internal compensation by comparison.

Set the configuration software to "internal thermo-element" and "Pt100 built-in".

7.1.1.2 Internal cold junction compensation with Pt100 connected to the terminals

For this alternative, a Pt 100 is connected to terminals ① and ④. Terminals ① and ② must be connected.

Set the configuration software to "internal thermo-element" and "Pt 100 on terminals".

7.1.1.3 External cold junction compensation

When using a cold junction thermostat, please observe that the correct reference temperature is configured. The connection between the cold junction thermostat and the transducer is made with copper wires.

7.1.2 Connection to resistance thermometers

7.1.2.1 Two-wire connection

Terminals ① and ②, ③ and ④ must be connected in the case of a two-wire measurement.

The lead resistance must not be greater than 30 Ω per lead.

7.1.2.2 Three-wire connection

Terminals ① and ② must be connected in the case of a three-wire measurement. It is not necessary to compensate the leads, providing the three leads have identical resistances. The lead resistance must not be greater than 30 Ω per lead.

7.1.2.3 Four-wire connection

The four-wire measurement is independent of lead resistance within wide limits and therefore no compensation is necessary. The lead resistance must not be greater than 30 Ω per lead.

7.2 Measuring output leads (output/powering circuit)

Connect the measuring output leads (analogue output and power supply) to terminals \ominus and \oplus acc. to Fig. 6).

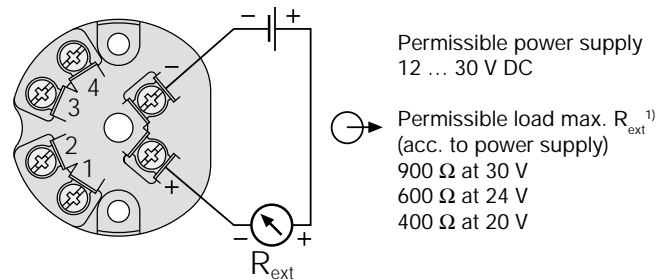

Fig. 6

Note that twisted leads must be used for the output signal.

VK 626 Type 626-7A0 Mat: 141424 / 6260000	Supply Voltage: 12...30V	Sensor: Pt100 3-wire Range: 0...100°C Output: 4...20mA		Camille Bauer AG Aargauerstr. 7 CH-5610 Wohlen Switzerland
--	--------------------------	--	--	---

Fig. 7. Example of a nameplate.

8. Configuring the transmitter

The SINEAX VK 626 with HART protocol is configured via a serial interface of a PC using the HART interface and the programming software.

The following accessories are required ...

... HART interface (e.g. Smar HI 311, MACTek Viator 010001, Siemens 7MF 4997-1DA)

... Configuration software V 600 plus

A PC with an RS 232 C interface (Windows 3.1x, 95, 98, NT or 2000) is also required.

The configuration procedure and choice of parameters is explained by the menu-guided configuration program.

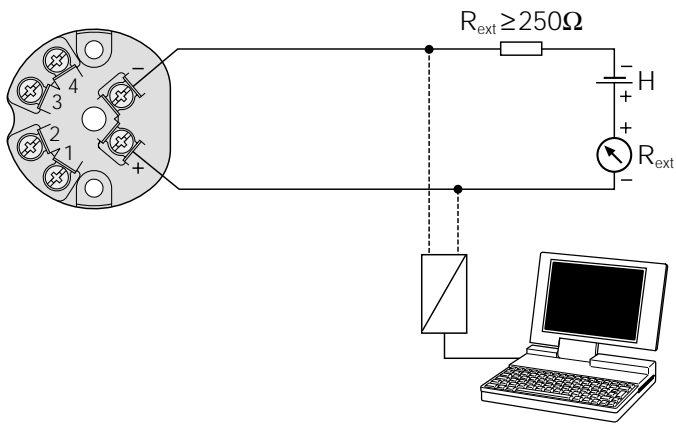

Fig. 8. Configuring of SINEAX VK 626 in standard version.

9. Commissioning



Switch on the measuring input and the power supply. The ambient temperature must be between -10 and $+80$ °C for standard instruments and -10 and max. 52 °C for Ex versions (depending on P_i , see type examination certificate).

10. Maintenance

No maintenance is required.

11. Accessories and spare parts

Description	Order No.
Configuration Software V 600 <i>plus</i> on CD (Download free of charge under http://www.gmc-instruments.com)	146 557
Operating Instructions VK 626 Bd in German	141 961
Operating Instructions VK 626 Bf in French	142 084
Operating Instructions VK 626 Be in English	142 133

12. Dimensional drawing

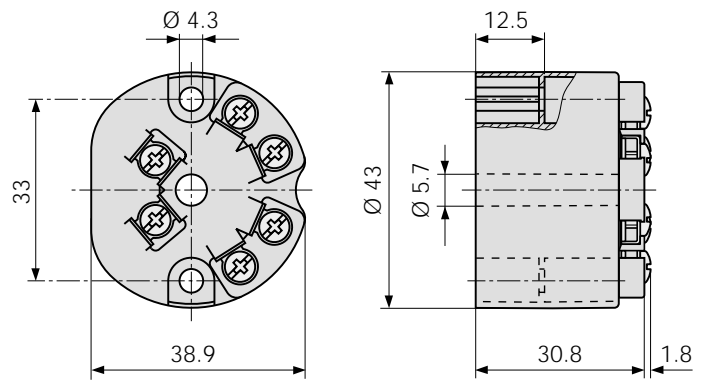

Fig. 9. SINEAX VK 626.

MOD-TRONIC
INSTRUMENTS LIMITED

48 Haggert Ave N
Brampton, ON L6X 1Y3
Tel: 905 457-6322
Fax: 905 457-4716
Toll Free: 800 794-5883