

DC Input DPDT Alarm Trip

API 1080 DIN



Input: 0-50 mV to ± 10 VDC or 0-1 mA to 4-20 mA
Output: One 7 Amp DPDT Relay

Field Selectable
One Minute Setup!



DC Input

- **Field Selectable Input Ranges**
- **Selectable Relay Configuration & Adjustable Setpoints**
- **Input LoopTracker® & Alarm Status LEDs**
- **Alarm Test/Reset Pushbutton**
- **Built-In 4-20 mA Loop Power Supply**
- **Compact 22.5 mm Wide DIN Package**
- **Operates on Wide Ranges of AC or DC Power**



Applications

- **Process Limit Backup Alarm**
- **Tank Level Alarm**
- **Over, Under, Out-of-Range Alarm**

Specifications

Input Ranges

	Minimum	Maximum
Voltage:	0-50 mVDC	± 10 VDC
Current:	0-1 mA DC	0-20 mA DC

See chart on other side for standard ranges
Consult factory for other available switch selectable ranges

Input Impedance

Voltage inputs: 250 k Ω minimum
Current inputs: 50 Ω typical

Input Voltage Burden

1.0 VDC typical at 20 mA

Input Protection, Common Mode

750 VDC or 750 VAC_p

Input Loop Power Supply

12 VDC $\pm 10\%$, regulated, 25 mA max. Max. ripple <1.5 V_{p-p}

LoopTracker

Variable brightness LED indicates input loop level and status

Relay Output

One DPDT contact, field configurable
7 A @ 240 VAC resistive load
3.5 A @ 240 VAC inductive load

CAUTION: External contact protection such as an RC snubber is recommended for inductive loads.

Setpoint

12 turn potentiometer adjustable from 0 to 100% of span

Deadband

Adjustable from 1.0 to 100% of span, 12 turn potentiometer

Functional Test/Reset Button

Toggles relay to opposite state when pressed
Resets latching relay if latching relay mode was selected

Response Time

70 milliseconds typical

Ambient Temperature Range and Temperature Stability

-10°C to +60°C operating ambient
Better than $\pm 0.02\%$ of span per °C temperature stability

Case Material

Polycarbonate, gray UL #94V-1 housing and black UL #94V-2 terminals

Power

Any AC source 80-265 VAC 50/60 Hz, 2 W max.
or any DC source 48-300 VDC, 2 W max.



Description and Features

The **API 1080 DIN** accepts a DC voltage or current input and provides a visual alarm indication and DPDT alarm relay contact output when the input exceeds a high alarm trip point or falls below a low alarm trip point. 15 voltage and 9 current input ranges can be field-configured via external rotary and slide switches. Offset ranges such as 1-5 VDC and 4-20 mA DC are also included. Consult the factory for other available ranges.

API exclusive features include a **LoopTracker** LED that varies in intensity with changes in the process signal, a bi-color alarm status LED, and a **Functional Test Pushbutton** to toggle the relay independent of the input. The green LoopTracker LED varies in intensity with changes in the process input signal. Monitoring the state of this LED can provide a quick visual picture of your process loop at all times. The functional test pushbutton can be used to verify the alarm and system operation and also provides the additional function of unlatching the alarm when the latching mode has been selected.

Heavy-duty relay contacts allow the module to directly control high capacity loads. The **API 1080 DIN** provides a single setpoint adjustment of the DPDT relay contacts. The alarm output can be field configured for HI or LO operation, latching or non-latching, and normal or reverse acting (also referred to as fail-safe or non-failsafe). Front-accessible potentiometers are used to adjust both the deadband from 1 to 100% and the alarm setpoint from 0 to 100%.

This module includes a regulated 12 VDC loop excitation supply that can be used to power an external loop-powered transmitter or other passive input device eliminating the need for an additional DC loop supply.

The **API 1080 DIN** is designed to mount on an industry-standard DIN rail. The narrow 22.5 mm wide DIN style housing allows for side-by-side mounting of multiple modules for maximum I/O density.

Models, Options & Accessories

Free Setup—Specify input range and output range

API 1080 DIN Field rangeable DC input, DPDT alarm trip, with loop power supply, 80-265 VAC or 48-300 VDC powered

Options—Add to end of model number

U Conformal coating for moisture resistance

Accessories—Order as a separate line item

API TK36 DIN rail, 35 mm W x 39" L, aluminum

MOD-TRONIC
INSTRUMENTS LIMITED

1 Delta Park Blvd #12
Brampton, ON L6T 5G1
905-457-6322 or 800-794-5883
www.mod-tronic.com



DC Input

ELECTRICAL CONNECTIONS

WARNING! All wiring must be performed by qualified personnel only. This module requires an industry-standard DIN rail mount. Order API TK36 DIN rail separately.

Power Input Terminals – The label on the side of the API module will indicate the voltage requirements. Power is connected to terminals 10 and 12. Observe polarity when using DC power. Positive (+) is wired to terminal 12 and negative (-) is wired to terminal 10. Terminal 11 earth ground may be used if required.

Powered Signal Input – Polarity must be observed when connecting the signal input. The positive connection (+) is applied to terminal 8 and the negative (-) is applied to terminal 7.

Using the 12 VDC Power Supply with a Passive Signal Input – This may save the expense of purchasing a separate power supply for the input device. A passive input device can be powered by the 12 volt DC power supply at terminal 9. Polarity must be observed when connecting the signal input. Typically the positive (+) lead is wired to terminal 9 and the negative (-) lead is connected to terminal 8. A typical example is shown. It is very important to consult the manufacturer of your specific sensor to determine its compatibility and proper wiring.

Relay Output Terminals – Terminals 6, 7, 8 and 9, 10, 11 provide the appropriate connections for the desired relay operations. (NO = Normally Open, NC = Normally Closed, C = Common).

WIRING EXAMPLES

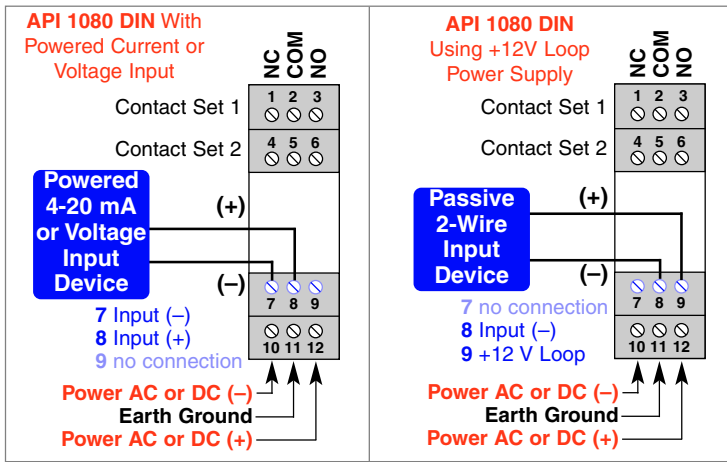

RANGE SELECTION

The API 1080 DIN input selector switch determines the input impedance for the module, typically 50 Ω for current inputs and 250 kΩ or greater for voltage inputs. The switch settings will determine the exact operation of the module. Following are the standard input range and alarm configuration tables used to configure the API 1080 DIN. Set switches A, B, C and D accordingly.

EXAMPLE: For 4-20 mADC input, HI alarm, non-latching, normal action. Set switches as follows: A = "I" (current); B = "5"; C = "F"; D = "2"

VOLTAGE Inputs Set switch A to "V"		CURRENT Inputs Set switch A to "I"		ALARM CONFIGURATION			
Range	Switches B C	Range	Switches B C	Type	Latch	Action	Switch D
0-50 mV	8 1	0-1 mA	C 1	HI	No	Normal	2
0-100 mV	9 1	0-2 mA	0 1	HI	No	Reverse	6
0-200 mV	A 1	0-4 mA	1 1	HI	Yes	Normal	0
0-250 mV	C 1	0-8 mA	2 1	HI	Yes	Reverse	4
0-400 mV	B 1	2-10 mA	2 F	LO	No	Normal	3
0-500 mV	0 1	0-10 mA	4 1	LO	No	Reverse	7
0-1 V	1 1	0-16 mA	3 1	LO	Yes	Normal	1
0-2 V	2 1	0-20 mA	5 1	LO	Yes	Reverse	5
0-2.5 V	4 1	4-20 mA	5 F				
0-4 V	3 1						
1-5 V	5 F						
0-5 V	5 1						
0-10 V	6 1						
±5 V	6 4						
±10 V	7 4						

API maintains a constant effort to upgrade and improve its products. Specifications are subject to change without notice. Consult factory for your specific requirements.

SETUP

Setpoint Control – This multi-turn potentiometer allows the operator to adjust the level at which the alarm is activated. This control is adjustable from 0 to 100% of the input range.

Deadband Control – This potentiometer allows the alarm trip and reset window to be adjusted symmetrically about the setpoint from 1 to 100% of the span. This allows the operator to fine tune the point at which the alarm trips and resets. The deadband is typically used to prevent chattering of the relays or false trips when the process signal is unstable or changes rapidly.

Test Switch and Test Range – The functional Test pushbutton toggles the alarm status independent of the input when depressed. It verifies the alarm and system operation without having to alter the input signal.

OPERATION

GREEN LoopTracker® Input LED – Provides a visual indication that a signal is being sensed by the input circuitry of the module. It indicates the input signal strength by changing in intensity as the process changes from minimum to maximum. If the LED fails to illuminate, or fails to change in intensity as the process changes, this may indicate a problem with module power or signal input wiring.

Bi-Color Alarm LED – Provides a visual indication of the alarm status. In all configurations, a GREEN LED indicates a non-alarm condition and a RED LED indicates an alarm condition.

Alarm Relays – In the normal mode of operation (failsafe), the relay coil is energized in a non-alarm condition and de-energized in an alarm condition. This will create an alarm condition if the module loses power. For a normal acting, non-latching configuration, the alarm will activate when the input signal exceeds the setpoint (HI alarm) or falls below the setpoint (LO alarm), then will automatically reset when the alarm condition no longer exists.

For a reverse acting alarm (non-failsafe), the relay coil is de-energized in a non-alarm condition and energized in an alarm condition. The alarm activates when the input signal exceeds the setpoint (HI alarm) or falls below the setpoint (LO alarm), then automatically resets when the alarm condition no longer exists.

When the latching mode is selected, it will be necessary to push the functional test pushbutton or remove power from the module to reset the alarm. The alarm will only reset if the alarm condition no longer exists.

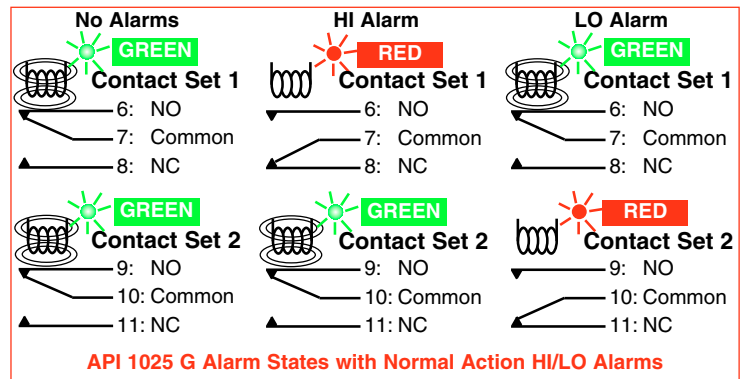

CALIBRATION

The input ranges are factory calibrated and do not require adjustment.

To calibrate the alarm section, set the deadband control to the minimum. Set the signal source to a reference that represents the desired trip point. Adjust the setpoint control to the point at which the relay changes state from a non-alarm to an alarm condition. The deadband will be 1.0% of span in this case.

If a larger amount of deadband is desired, the deadband control may be increased by turning the control clockwise. The deadband is symmetrical about the setpoint; both transition points will change as deadband is increased. In addition, the test button can be used at any time to toggle the relay state independent of the input and the output to verify system operation.



Auto-Ranging Flow Meter

PROBLEM

A flow in a process must be accurately measured throughout a wide range. The flow rate is used by a PLC to control the process. Two flow meters are utilized, one very accurate at low flow and one very accurate at high flow. A means for automatic selection of the appropriate flow meter is required.

SOLUTION

An **API 7580 G** Field Selectable Isolated Frequency to DC Transmitter module is used with each flow meter to convert the frequency output to a 0-10 VDC signal proportional to flow. An **API 1080 DIN** DC Input, Wide Ranging, Field Selectable Single Alarm Trip module monitors the flow rate and transfers the PLC analog input to the flow meter appropriate for that range.

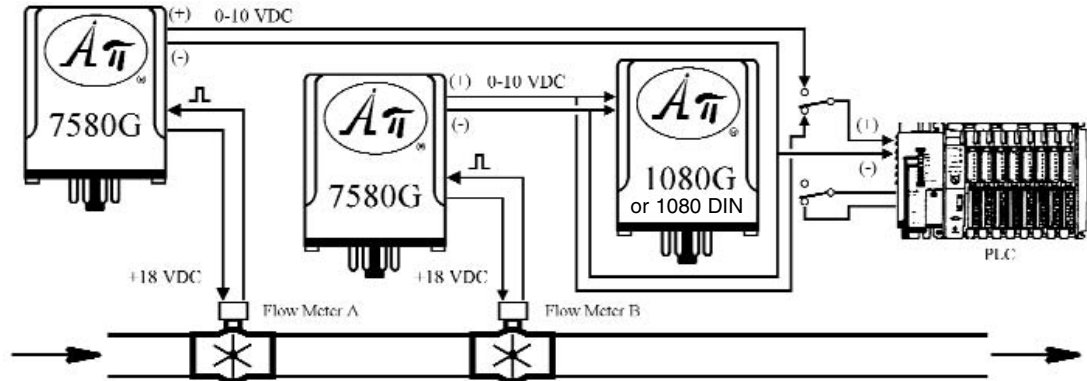

The second set of relay contacts of the **API 1080 DIN** provides a PLC binary input with a closure to indicate which flow meter is selected.

Pumping System High Pressure Shutdown

PROBLEM

High head pressure is causing pump failures. If the pressure exceeds a preset limit, the pump must be shut down. A manual reset is necessary to restart pump.

SOLUTION

A loop powered pressure transducer is installed at the discharge side of the pump. The pressure transducer is connected to an **API 1080 DIN** DC Input, Field Selectable Single Setpoint Alarm module.

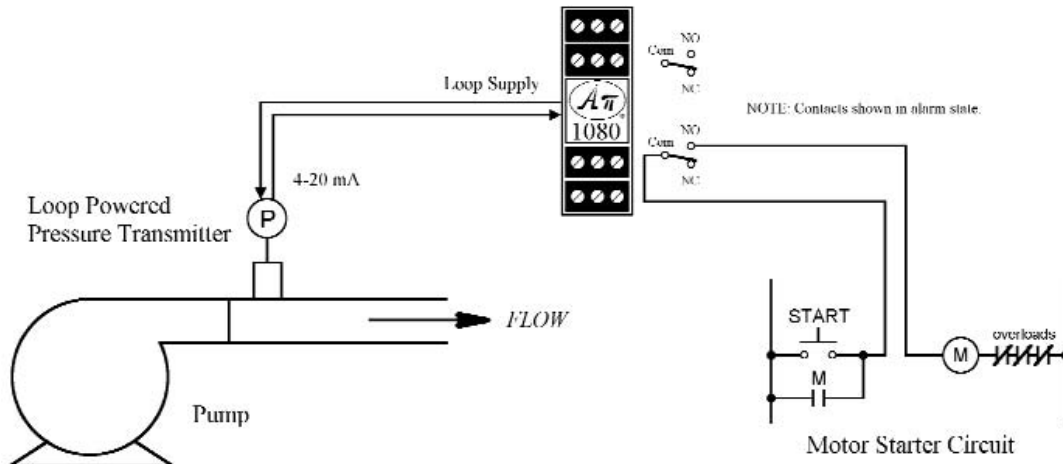

The **API 1080 DIN** provides the loop power for the 4-20 mA pressure transducer from its built-in loop excitation supply. The setpoint is adjusted to the high-pressure limit. The relay contacts are wired in series with the motor starter such that if the pressure is not below the setpoint, the pump will be stopped. It is necessary to press the START push button to restart the pump. The standard heavy-duty relay contacts are rated 7A @ 240 VAC and can directly control most devices.

FREE APPLICATION ASSISTANCE
 Call Customer Service
800-794-5883



1 Delta Park Blvd #12
 Brampton, ON L6T 5G1
 905-457-6322 or 800-794-5883
 www.mod-tronic.com



Frequently Asked Questions

What is Deadband?

DEFINITION

Deadband is the range through which an input can be varied without initiating an observable response. Deadband is usually expressed in percent of span.

EXAMPLE

A 20% total deadband is applied to the setpoint of a monitored parameter. The relay will trip and reset to its untripped state as indicated in the following graph.

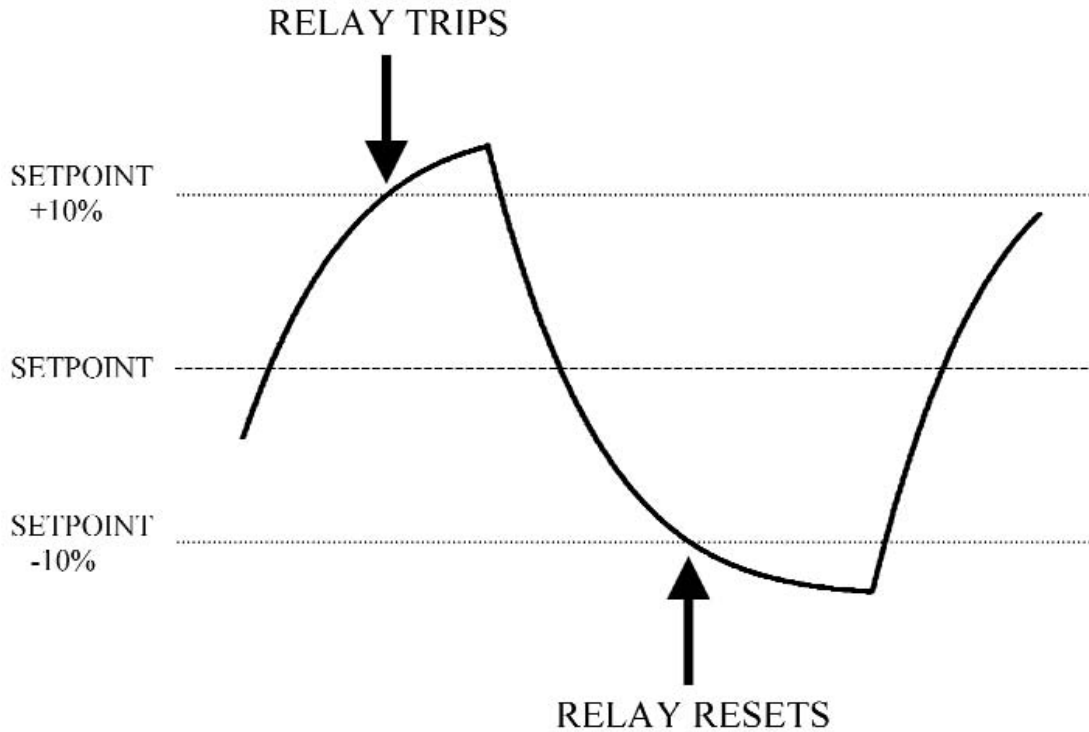

20% TOTAL DEADBAND

We have a relay alarm output and would like to adjust the set point for 5 VDC input and the reset point for 4 VDC input. How do we adjust the set point pot and the deadband pot to do this?

The deadband is the difference in the input signal between the points at which the relay energizes and de-energizes. The midpoint between the set and reset points is 4.5 VDC. Turn the deadband pot fully counterclockwise for minimum deadband. With a 4.5 VDC input signal, turn the set point pot until the relay changes state. Then, increase the the input signal to 5 VDC. Turn the deadband pot clockwise until the relay changes state.



FREE APPLICATION ASSISTANCE

Call **Customer Service**

800-794-5883

MOD-TRONIC
INSTRUMENTS LIMITED

1 Delta Park Blvd #12
Brampton, ON L6T 5G1
905-457-6322 or 800-794-5883
www.mod-tronic.com

API maintains a constant effort to upgrade and improve its products. Specifications are subject to change without notice. Consult factory for your specific requirements.