

# DC Input Dual SPDT Alarm Trip

# API 1090 G



**Input:** 0-50 mV to  $\pm 10$  VDC or 0-1 mA to 4-20 mA  
**Outputs:** Two 7 Amp SPDT Relays



**Field Selectable**  
**One Minute Setup!**

- **Field Selectable Input Ranges**
- **Selectable Relay Configuration & Adjustable Setpoints**
- **Input LoopTracker® & Alarm Status LEDs**
- **Alarm Test/Reset Pushbutton**
- **Built-In 4-20 mA Loop Power Supply**

## Applications

- **Process Limit Backup Alarm**
- **Tank Level Alarm**
- **Over, Under, Out-of-Range Alarm**

## Specifications

### Input Ranges

	Minimum	Maximum
Voltage:	0-50 mVDC	$\pm 10$ VDC
Current:	0-1 mA DC	0-20 mA DC

See chart on other side for standard ranges

Consult factory for other available switch selectable ranges

### Input Impedance

Voltage input:	250 k $\Omega$ minimum
Current input:	50 $\Omega$ typical

### Input Voltage Burden

1.0 VDC typical at 20 mA

### Input Protection, Common Mode

750 VDC or 750 VAC<sub>p</sub>  
 System voltages should not exceed socket voltage rating

### Input Loop Power Supply

18 VDC nominal, unregulated, 25 mA DC  
 Maximum ripple, less than 1.5 V<sub>p-p</sub>

### LoopTracker

Variable brightness LED indicates input loop level and status

### Relay Output

Two SPDT relays, field configurable  
 7 A @ 240 VAC resistive load, 3.5 A @ 240 VAC inductive load

**CAUTION:** Socket voltage rating may limit system rating.  
 External contact protection such as an RC snubber is recommended for inductive loads.

### Setpoint

12 turn potentiometer adjustable from 0 to 100% of span

### Deadband

Adjustable from 1.0 to 100% of span, 12 turn potentiometer

### Functional Test/Reset Button

Toggles relays to opposite state when pressed  
 Resets latching relays if latching relay mode was selected

### Response Time

70 milliseconds typical

### Ambient Temperature Range

-10°C to +60°C operating ambient

### Temperature Stability

Better than  $\pm 0.02\%$  of span per °C temperature stability

### Power

Standard:	115 VAC $\pm 10\%$ , 50/60 Hz, 2.5 W max.
A230 option:	230 VAC $\pm 10\%$ , 50/60 Hz, 2.5 W max.
D option:	9-30 VDC, 2.5 W typical

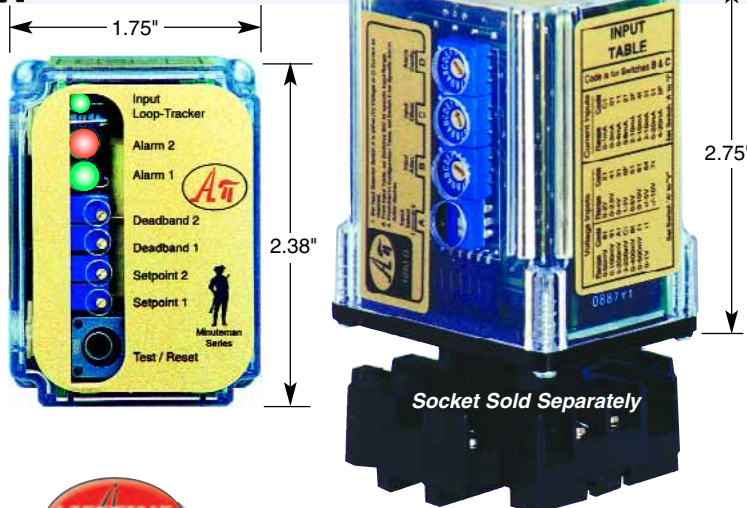

**Free Factory**  
**Input & Output**  
**Calibration!**

## Description and Features

The **API 1090 G** accepts a DC voltage or current input and provides a visual alarm indication and two independent alarm outputs via SPDT relay contacts for each setpoint. 17 voltage and 9 current input ranges can be field-configured via external rotary and slide switches. Offset ranges such as 1-5 VDC and 4-20 mA DC are also included. Consult the factory for other available ranges.

API exclusive features include a **LoopTracker** LED that varies in intensity with changes in the process signal, a bi-color alarm status LED, and a **Functional Test Pushbutton** to toggle both relays independent of the input. The green LoopTracker LED varies in intensity with changes in the process input signal. Monitoring the state of this LED can provide a quick visual picture of your process loop at all times. The functional test pushbutton toggles the alarm status independent of the input when depressed. It verifies the alarm and system operation and also provides the additional function of unlatching the alarm when the latching mode has been selected.

Heavy-duty relay contacts allow the module to directly control high capacity loads. The alarm outputs can be configured in the field for HI/HI, LO/LO, HI/LO or LO/HI operation, latching or non-latching, and normal or reverse acting (also referred to as fail-safe or non-fail-safe). Top-accessible, multi-turn potentiometers are used to adjust the deadband from 1 to 100% and the alarm setpoints from 0 to 100%.

This module includes an unregulated 18 VDC loop excitation supply that can be used to power an external loop-powered transmitter or other passive input device eliminating the need for an additional DC loop supply.

## Models, Options & Accessories

*Free Setup—Specify input range and output range*

**API 1090 G** Field rangeable DC input alarm trip, 2 SPDT relays, with loop power supply, 115 VAC

*Options—Add to end of model number*

<b>A230</b>	Powered by 230 VAC, 50/60 Hz
<b>D</b>	Powered by 9-30 VDC
<b>U</b>	Conformal coating for moisture resistance

*Accessories—Order as a separate line item*

<b>API 011</b>	11-pin socket
<b>API 011 FS</b>	11-pin finger safe socket
<b>API TK36</b>	DIN rail, 35 mm W x 39" L, aluminum

**MOD-TRONIC**  
 INSTRUMENTS LIMITED

1 Delta Park Blvd #12  
 Brampton, ON L6T 5G1  
 905-457-6322 or 800-794-5883  
 www.mod-tronic.com



DC Input

## ELECTRICAL CONNECTIONS

**WARNING!** All wiring must be performed by qualified personnel only. This module requires an industry-standard 11-pin socket. Order API 011 or finger-safe API 011 FS socket separately.

**Power Input Terminals** – The white label on the side of the API module will indicate the power requirements. AC power is connected to terminals 1 and 3. For DC powered modules, polarity **MUST** be observed. Positive (+) is wired to terminal 1 and negative (-) is wired to terminal 3.

**Signal Input** – Polarity must be observed when connecting the signal input. The positive connection (+) connects to terminal 4 and the negative (-) is connects to terminal 5.

**Relay Output Terminals** – Terminals 6, 7, 8 and 9, 10, 11 provide the connections for the relays. NO = Normally Open, NC = Normally Closed, C = Common.

## WIRING EXAMPLES

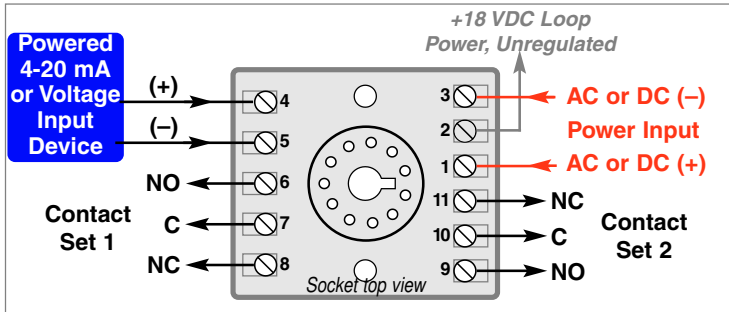

API 1090 G with Powered Current or Voltage Input

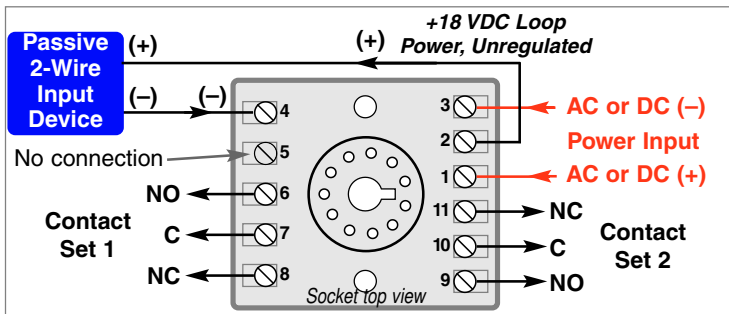

API 1090 G Using +18V Loop Power Supply

## SETUP

The API 1090 G input selector switch determines the input impedance for the module, typically 50 Ω for current inputs and 250 kΩ or greater for voltage inputs. The switch settings will determine the exact operation of the module. Following are the standard input range and alarm configuration tables used to configure the API 1090 G. Set switches A, B, C and D accordingly.

VOLTAGE Inputs		CURRENT Inputs		ALARM CONFIGURATION			
Set switch A to "V"	Switches B C	Set switch A to "I"	Switches B C	SP1/SP2	Latch	Action	Switch D
0-50 mV	8 1	0-1 mA	C 1	HI/LO	No	Normal	6
0-100 mV	9 1	0-2 mA	0 1	HI/LO	No	Reverse	E
0-200 mV	A 1	0-4 mA	1 1	HI/LO	Yes	Normal	2
0-250 mV	C 1	0-8 mA	2 1	HI/LO	Yes	Reverse	A
0-400 mV	B 1	2-10 mA	2 F	HI/LO	No	Normal	4
0-500 mV	0 1	0-10 mA	4 1	HI/LO	No	Reverse	C
±50 mV	A 4	0-16 mA	3 1	HI/LO	Yes	Normal	0
±100 mV	B 4	0-20 mA	5 1	HI/LO	Yes	Reverse	8
0-1 V	1 1	4-20 mA	5 F	LO/LO	No	Normal	7
0-2 V	2 1			LO/LO	No	Reverse	F
0-2.5 V	4 1			LO/LO	Yes	Normal	3
0-4 V	3 1			LO/LO	Yes	Reverse	B
1-5 V	5 F			LO/LO	Yes	Reverse	B
0-5 V	5 1			LO/LO	No	Normal	5
0-10 V	6 1			LO/LO	No	Reverse	D
±5 V	6 4			LO/LO	Yes	Normal	1
±10 V	7 4			LO/LO	Yes	Reverse	9

API maintains a constant effort to upgrade and improve its products. Specifications are subject to change without notice. Consult factory for your specific requirements.

## SETUP (Continued)

**EXAMPLE:** For 4-20 mA DC input, HI alarm, non-latching, normal action set switches as follows:

- A = I (current)
- B = 5
- C = F
- D = 6

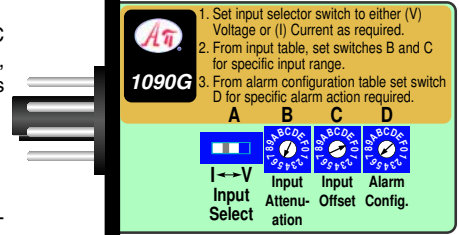

**Setpoint Control** – The multi-turn potentiometers (one for each setpoint) allow the operator to adjust the level at which each alarm is activated. These controls are adjustable from 0 to 100% of the input range.

**Deadband Control** – These potentiometers allow the alarm trip and reset windows to be adjusted symmetrically about the setpoint from 1 to 100% of the span for each setpoint. This allows the operator to fine tune the point at which each alarm trips and resets and is typically used to prevent chattering of the relays or false trips when the process signal is unstable or changes rapidly.

**Test Switch** – The functional Test pushbutton toggles the alarm status independent of the input when depressed. It verifies the alarm and system operation without having to alter the input signal.

## OPERATION

**GREEN LoopTracker® Input LED** – Provides a visual indication that a signal is being sensed by the input circuitry of the module. It indicates the input signal strength by changing in intensity as the process changes from minimum to maximum. If the LED fails to illuminate, or fails to change in intensity as the process changes, this may indicate a problem with module power or signal input wiring.

**Bi-Color Alarm LED** – Provides a visual indication of the alarm status. In all configurations, a GREEN LED indicates a non-alarm condition and a RED LED indicates an alarm condition.

**Alarm Relays** – In the normal mode of operation (failsafe), the relay coil is energized in a non-alarm condition and de-energized in an alarm condition. This will create an alarm condition if the module loses power. For a normal acting, non-latching configuration, the alarm will activate when the input signal exceeds the setpoint (HI alarm) or falls below the setpoint (LO alarm), then will automatically reset when the alarm condition no longer exists.

For a reverse acting alarm (non-failsafe), the relay coil is de-energized in a non-alarm condition and energized in an alarm condition. The alarm activates when the input signal exceeds the setpoint (HI alarm) or falls below the setpoint (LO alarm), then automatically resets when the alarm condition no longer exists.

When the latching mode is selected, it will be necessary to push the functional test pushbutton or remove power from the module to reset the alarm. The alarm will only reset if the alarm condition no longer exists.

## CALIBRATION

The input ranges are factory calibrated and no field calibration is required. To calibrate the alarm section, set the deadband control to the minimum. Set the signal source to a reference that represents the desired trip point. Adjust the setpoint control to the point at which the relay changes state from a non-alarm to an alarm condition. The deadband will be 1.0% of span in this case.

Turn the deadband potentiometer clockwise if a larger amount of deadband is desired. The deadband is symmetrical about the setpoint; both transition points will change as deadband is increased. The test button can be used at any time to toggle the relay state independent of the input and output to verify operation.

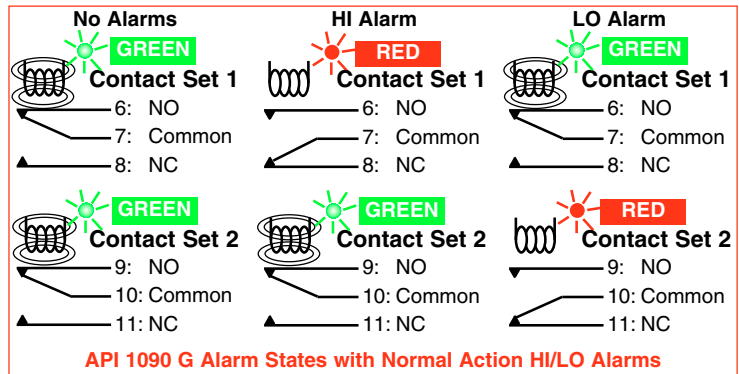

API 1090 G Alarm States with Normal Action HI/LO Alarms