

DC to DC Isolator Field Rangeable Transmitter

API 4380 DIN API 4380 DD



Input: 0-50 mV to ± 10 VDC, 0-1 mA to 0-20 mA
Output: 0-1 V to ± 10 VDC or 0-2 mA to 4-20 mA

- One Minute Setup for Hundreds of I/O Ranges
- External Switches & Tables for Range Selection
- 2000 V Full Isolation Input/Output/Power
- Input and Output LoopTracker® LEDs
- Functional Test Pushbutton

Applications

- Isolate, Convert, Boost, Rescale Process Signals
- One Model to Interface Process Signals with Panel Meters, Recorders, Data Acquisition Cards, PLCs, DCS Systems, SCADA Systems

Specifications

Input Ranges

Consult factory for optional switch selectable ranges within input & output limits.

	Minimum	Maximum
Voltage:	0 to 50 mVDC	0 to 10 VDC
Bipolar Voltage:	± 50 mVDC	± 10 VDC
Current:	0 to 1 mADC	0 to 20 mADC

Input Impedance

Voltage:	1 M Ω minimum
Current:	50 Ω typical Input voltage burden (current) 1 VDC at 20 mA

Input Loop Power Supply

12 VDC nominal, regulated, 25 mADC, max. ripple, less than 1.5 V_{p-p}

LoopTracker

Variable brightness LEDs indicate input and output loop levels and status

Output Ranges

	Minimum	Maximum	Load Factor
Voltage:	0-1 VDC	0-10 VDC	
Bipolar Voltage:	± 1 VDC	± 10 VDC	
Current (20 V compliance):	0-2 mADC	0-20 mADC	1000 Ω at 20 mA

Output Zero and Span

Multiturn potentiometers to compensate for load and lead variations
 $\pm 15\%$ of span adjustment range typical

Output Linearity

Better than $\pm 0.1\%$ of span

Output Ripple and Noise

Less than 10 mV_{RMS}

Functional Test Button

Sets output to test level when pressed
 Potentiometer factory set to approximately 50% of span
 Adjustable 0-100% of span

Response Time

Standard: 100 milliseconds typical

Isolation

1000 V_{RMS} minimum
 Full isolation: power to input, power to output, input to output

Ambient Temperature Range and Stability

-10°C to $+60^{\circ}\text{C}$ operating ambient
 Better than $\pm 0.02\%$ of span per $^{\circ}\text{C}$ temperature stability

Case Material

Polycarbonate, gray UL #94V-1 housing and black UL #94V-2 terminals

Power

Standard:	115 VAC $\pm 10\%$, 50/60 Hz, 2.5 W max.
A230 option:	230 VAC $\pm 10\%$, 50/60 Hz, 2.5 W max.
D option:	9-30 VDC, 2.5 W typical

© Absolute Process Instruments, Inc. 11/04 LoopTracker—Reg TM Absolute Process Instruments, Inc.

Wide Ranging I/O
One Minute Setup!



Free Factory
Input & Output
Calibration!

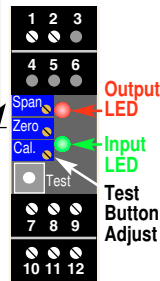

Description and Features

The API 4380 DIN and API 4380 DD accept a DC voltage or current input and provides an optically isolated DC voltage or current output that is linearly related to the input. Typical applications include signal isolation, signal conversion, signal boosting or a combination of the three.

The optical isolation between input and output makes this module useful for ground loop elimination, common mode signal rejection or noise pickup reduction. The module power supply is isolated, resulting in full 3-way (input, output, power) isolation.

The API 4380 DIN and API 4380 DD can be field-configured via external rotary and slide switches. Most common ranges are built-in, and can be selected from the table on the module, however virtually unlimited combinations are possible. Consult the factory for assistance with special ranges.

The API 4380 DIN and API 4380 DD are designed to mount on industry-standard DIN rails. The narrow DIN style housing (22.5 mm) allows for side-by-side mounting of multiple modules for maximum I/O density.

API exclusive features include two LoopTracker LEDs and a Functional Test Pushbutton. The LoopTracker LEDs (Green for input, Red for output) vary in intensity with changes in the process input and output signals. Monitoring the state of these LEDs can provide a quick visual picture of your process loop at all times. The functional test pushbutton provides a fixed output (independent of the input) when held depressed. The test output level can be field-adjusted via a multiturn potentiometer.

Both the LoopTracker LEDs and functional test pushbutton greatly aid in saving time during initial startup and/or troubleshooting. The built-in 12 VDC regulated loop excitation power supply can be used to power passive input devices.

Models & Options

- API 4380 DIN** Field rangeable DC to DC transmitter, isolated, with loop power supply, 80 to 265 VAC or 48 to 300 VDC
- API 4380 DD** Field rangeable DC to DC transmitter, isolated, with loop power supply, 9 to 30 VDC

Options—Add to end of model number
U Conformal coating for moisture resistance

Accessories—Order as separate line item
API TK36 DIN rail, 35 mm W x 39" L, aluminum

MOD-TRONIC
INSTRUMENTS LIMITED

1 Delta Park Blvd #12
 Brampton, ON L6T 5G1
 905-457-6322 or 800-794-5883
 www.mod-tronic.com

DC Input



ELECTRICAL CONNECTIONS

WARNING! All wiring must be performed by qualified personnel only. This module requires an industry-standard 8-pin socket. Order API 008 or finger-safe API 008 FS socket separately.

Power Input Terminals – The label on the side of the API module will indicate the power requirements. Power is connected to terminals 10 and 12. For DC powered modules, polarity MUST be observed. Positive (+) is wired to terminal 12 and negative (-) is wired to terminal 10. Terminal 11 earth ground may be used if required.

Powered Signal Input – Polarity must be observed when connecting the signal input. The positive connection (+) is applied to terminal 8 and the negative (-) is applied to terminal 7.

Using the 12 VDC Power Supply with a Passive Signal Input – This may save the expense of purchasing a separate power supply for the input device. A passive input device can be powered by the 12 volt DC power supply at terminal 9. Polarity must be observed when connecting the signal input. Typically the positive (+) lead is wired to terminal 9 and the negative (-) lead is connected to terminal 8. A typical example is shown. It is very important to consult the manufacturer of your specific sensor to determine its compatibility and proper wiring.

Signal Output Terminals – Polarity must be observed when connecting the signal output to the load. The positive connection (+) is connected to terminal 2 and the negative (-) is connected to terminal 1.

WIRING EXAMPLES

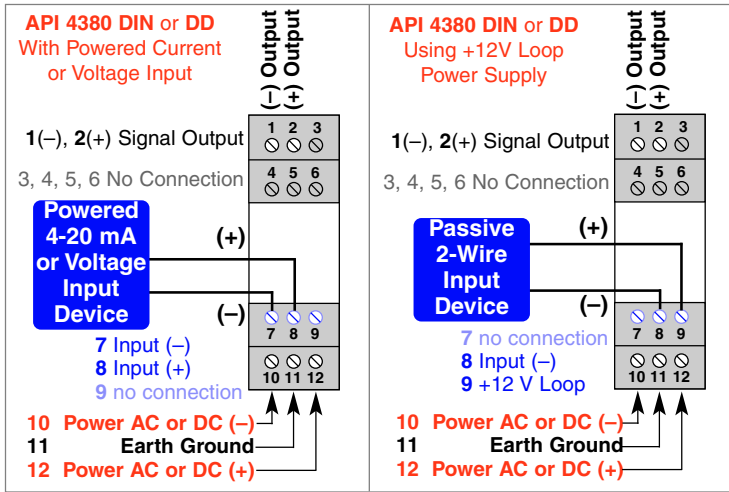

RANGE SELECTION

Three rotary switches and two slide switches located on the side of the module are used to select input and output ranges. Most popular ranges are listed on the module labels. See www.api-usa.com or contact factory for special ranges.

- Set the **INPUT SELECT** slide switch to current (I) or voltage (V) depending on input type. The input selector switch determines the input impedance for the module, typically 50 Ω for current inputs and 1 MΩ or greater for voltage inputs.
- Set the **OUTPUT SELECT** slide switch to current (I) or voltage (V) depending on output type.
- From the table, find the rotary switch combination that matches your input and output ranges.
- Set the three rotary switches **A**, **B**, and **C** to the values found in the table.
- The Zero, Span and Test Range potentiometers can now be adjusted for the desired output range.

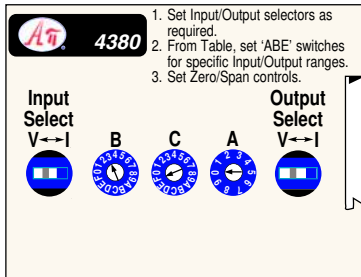

Depending on the rotary switch settings, the input is filtered, either amplified or attenuated as required, then passed through an optical isolation circuit to the output stage.

CALIBRATION

Input and output ranges are pre-configured at the factory as specified on your order. Front-mounted, Zero and Span potentiometers can be used should fine-tuning be necessary. Custom ranges may require factory modification.

- Apply power to the module and allow a minimum 20 minute warm up time.
- Using an accurate calibration source, provide an input to the module equal to the minimum input required for the application.
- Using an accurate measurement device for the output, adjust the Zero potentiometer for the exact minimum output desired. The Zero control should only be adjusted when the input signal is at its minimum. This will produce the corresponding minimum output signal. Example: For 4-20 mA output signal, the Zero control will provide adjustment for the 4 mA or low end of the signal.
- Set the input at maximum, and then adjust the Span pot for the exact maximum output desired. The Span control should only be adjusted when the input signal is at its maximum. This will produce the corresponding maximum output signal. Example: For 4-20 mA output signal, the Span control will provide adjustment for the 20 mA or high end of the signal.
- Repeat adjustments for maximum accuracy.

TEST BUTTON & TEST RANGE

The Test pushbutton may be set to provide the desired output when depressed. This will drive the device on the output side of the loop (a panel meter, chart recorder, etc.) with a known good signal that can be used as a system diagnostic aid during initial start-up or during troubleshooting. It can be adjusted to vary the output signal from 0 to 100% of the calibrated output range. When released, the output will return to normal.

Turn the multi-turn Test Range potentiometer while holding the Test Switch depressed until the desired output test level is reached.

Example: If you are isolating a 4-20 mA current loop, when the pushbutton is held depressed, the output from the module will be a constant signal between 4 and 20 mA depending on the setting of the Test Range adjustment pot.

OPERATION

GREEN LoopTracker® Input LED – Provides a visual indication that a signal is being sensed by the input circuitry of the module. It also indicates the input signal strength by changing in intensity as the process changes from minimum to maximum. If the LED fails to illuminate, or fails to change in intensity as the process changes, this may indicate a problem with module power or signal input wiring.

RED LoopTracker output LED – Provides a visual indication that the output signal is functioning. It becomes brighter as the input and the corresponding output change from minimum to maximum. For current outputs, the RED LED will only light if the output loop current path is complete. For either current or voltage outputs, failure to illuminate or a failure to change in intensity as the process changes may indicate a problem with the module power or signal output wiring.

		OUTPUT RANGES								
		0-1 V	0-2 V	0-5 V	1-5 V	0-10 V	±5 V	±10 V	4-20 mA	0-20 mA
Rotary Switches		ABE	ABE	ABE	ABE	ABE	ABE	ABE	ABE	ABE
I N P U T	0-50 mV	081	181	381	283	681	881	981	583	681
	0-100 mV	091	191	391	293	691	891	991	593	691
	0-200 mV	0A1	1A1	3A1	2A3	6A1	8A1	9A1	5A3	6A1
	0-500 mV	001	101	301	203	601	801	901	503	601
	0-1 V	011	111	311	213	611	811	911	513	611
O U T	0-2 V	021	121	321	223	621	821	921	523	621
	1-5 V	03F	13F	33F	231	63F	83F	93F	531	63F
	0-5 V	051	151	351	253	651	851	951	553	651
R A N G E	0-10 V	061	161	361	263	661	861	961	563	661
	±5 V	064	164	364	266	664	864	964	566	664
	±10 V	074	174	374	276	674	874	974	576	674
	0-1 mA	0C1	1C1	3C1	2C3	6C1	8C1	9C1	5C3	6C1
S	4-20 mA	03F	13F	33F	231	63F	83F	93F	531	63F
	0-20 mA	051	151	351	253	651	851	951	553	651

API maintains a constant effort to upgrade and improve its products. Specifications are subject to change without notice. Consult factory for your specific requirements.



RANGE SELECTION

Three rotary switches and two slide switches located on the side of the module are used to select input and output ranges. Most popular ranges are listed on the module labels. See www.api-usa.com or contact factory for special ranges.

1. Set the **INPUT SELECT** slide switch to current (I) or voltage (V) depending on input type. The input selector switch determines the input impedance for the module, typically 50 Ω for current inputs and 1 MΩ or greater for voltage inputs.
2. Set the **OUTPUT SELECT** slide switch to current (I) or voltage (V) depending on output type.
3. From the table, find the rotary switch combination that matches your input and output ranges.
4. Set the three rotary switches **A**, **B**, and **C** to the values found in the table.
5. The Zero, Span and Test Range potentiometers can now be adjusted for the desired output range.

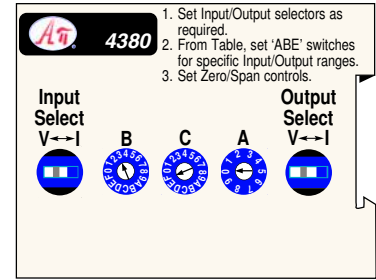
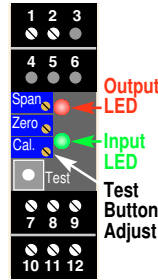

Depending on the rotary switch settings, the input is filtered, either amplified or attenuated as required, then passed through an optical isolation circuit to the output stage.

Rotary Switches		OUTPUT RANGES																
		0-1 V	0-2 V	0-4 V	0-5 V	1-5 V	0-8 V	2-10 V	0-10 V	±5 V	±10 V	0-2 mA	0-10 mA	2-10 mA	0-16 mA	4-20 mA	0-20 mA	
		ABE	ABE	ABE	ABE	ABE	ABE	ABE	ABE	ABE	ABE	ABE	ABE	ABE	ABE	ABE	ABE	
I N P U T	0-50 mV	081	181	281	381	283	581	583	681	881	981	081	381	283	581	583	681	
	0-100 mV	091	191	291	391	293	591	593	691	891	991	091	391	293	591	593	691	
	0-200 mV	0A1	1A1	2A1	3A1	2A3	5A1	5A3	6A1	8A1	9A1	0A1	3A1	2A3	5A1	5A3	6A1	
	0-250 mV	0C1	1C1	2C1	3C1	2C3	5C1	5C3	6C1	8C1	9C1	0C1	3C1	2C3	5C1	5C3	6C1	
	0-400 mV	0B1	1B1	2B1	3B1	2B3	5B1	5B3	6B1	8B1	9B1	0B1	3B1	2B3	5B1	5B3	6B1	
	0-500 mV	001	101	201	301	203	501	503	601	801	901	001	301	203	501	503	601	
	R A N G E S	0-1 V	011	111	211	311	213	511	513	611	811	911	011	311	213	511	513	611
		0-2 V	021	121	221	321	223	521	523	621	821	921	021	321	223	521	523	621
		0-2.5 V	041	141	241	341	243	541	543	641	841	941	041	341	243	541	543	641
		0-4 V	031	131	231	331	233	531	533	631	831	931	031	331	233	531	533	631
1-5 V		03F	13F	23F	33F	231	53F	531	63F	83F	93F	03F	33F	231	53F	531	63F	
0-5 V		051	151	251	351	253	551	553	651	851	951	051	351	253	551	553	651	
0-10 V		061	161	261	361	263	561	563	661	861	961	061	361	236	561	563	661	
±5 V		064	164	264	364	266	564	566	664	864	964	064	364	266	564	566	664	
±10 V		074	174	274	374	276	574	576	674	874	974	074	374	276	574	576	674	
R A N G E S		0-1 mA	0C1	1C1	2C1	3C1	2C3	5C1	5C3	6C1	8C1	9C1	0C1	3C1	2C3	5C1	5C3	6C1
	0-2 mA	001	101	201	301	203	501	503	601	801	901	001	301	203	501	503	601	
	0-4 mA	011	111	211	311	213	511	513	611	811	911	011	311	213	511	513	611	
	0-8 mA	021	121	221	321	223	521	523	621	821	921	021	321	223	521	523	621	
	0-10 mA	041	141	241	341	243	541	543	641	841	941	041	341	243	541	543	641	
	0-16 mA	031	131	231	331	233	531	533	631	831	931	031	331	233	531	533	631	
	4-20 mA	03F	13F	23F	33F	231	53F	531	63F	83F	93F	03F	33F	231	53F	531	63F	
	0-20 mA	051	151	251	351	253	551	553	651	851	951	051	351	253	551	553	651	
2-10 mA	02F	12F	22F	32F	221	52F	521	62F	82F	92F	02F	32F	221	52F	521	62F		



FREE APPLICATION ASSISTANCE

Call Customer Service

800-794-5883

MOD-TRONIC
INSTRUMENTS LIMITED

1 Delta Park Blvd #12
Brampton, ON L6T 5G1
905-457-6322 or 800-794-5883
www.mod-tronic.com



Controlling and Monitoring Liquid Flow from a Single Flowmeter

PROBLEM

A process requires a controlled flow rate of a liquid with a local display of that flow rate and a chart of the flow rate for record keeping purposes.

SOLUTION

A single flow meter can be utilized for control and monitoring of flow rate if appropriate signal conditioning is provided. In this example, the local display and the flow controller require a 4-20 mADC signal, while the remote chart recorder requires a 0-5 VDC signal.

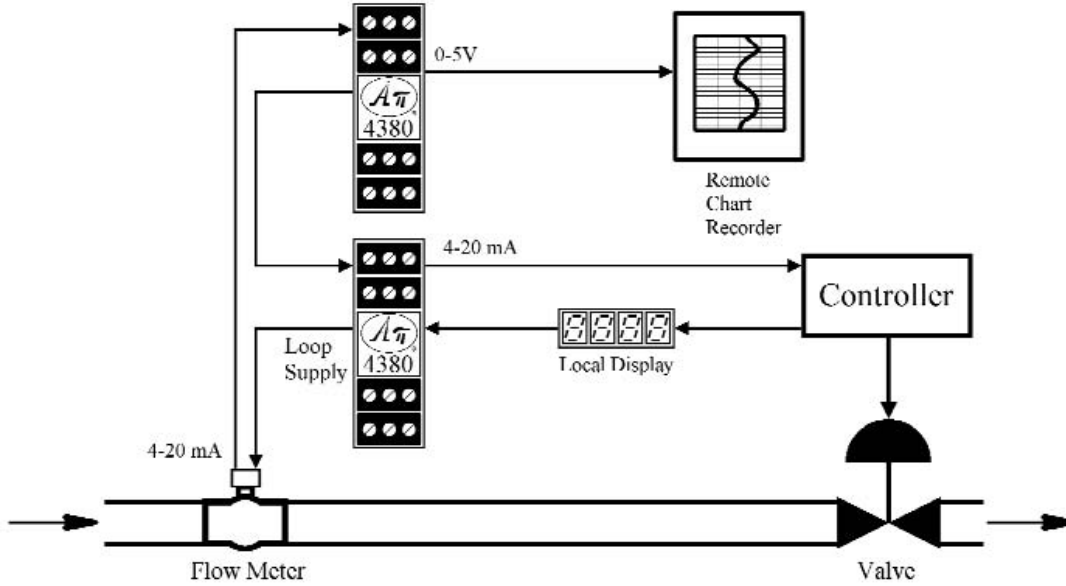

The flow meter is connected to a pair of **API 4380 DIN** Isolated, Field Ranging DC to DC Isolators. The first **API 4380 DIN** provides loop power for the flow meter from its built-in loop excitation supply, and its 4-20 mADC output drives both the local display and the flow controller. The second **API 4380 DIN** converts the 4-20 mADC signal from the flow meter to a 0-5 VDC signal which is sent to the remotely located chart recorder.

Motor Load Monitoring

PROBLEM

The load on a DC motor needs to be monitored by a computer control system. A 100 mV shunt is used to measure motor current. Due to signal noise concerns and distance, a 4-20 mA signal is used. If the shunt is connected directly to the computer measuring system, the computer system's input board would provide a voltage ground path from the DC motor. This result would be an electrical short and spectacular destruction of the computer.

SOLUTION

The standard **API 4380 DIN** Isolated DC to DC Transmitter accepts the 0 to 100 mV input, provides optical isolation and converts it to an isolated 4-20 mA signal that can be used by the computer system.

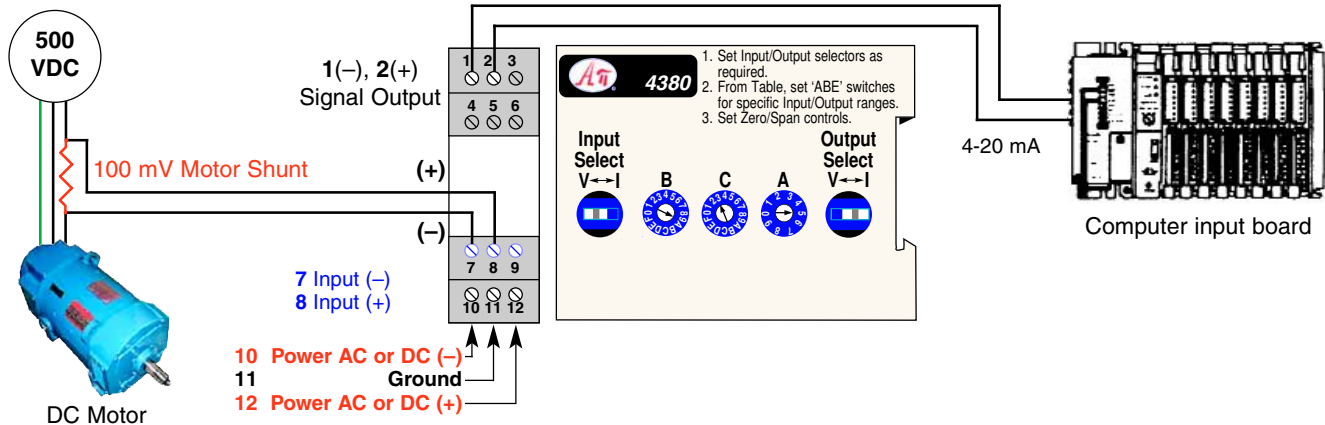

The **API 4380 DIN** switches are set to input select "V", Output select "I" and A=5, B=9, and C=3 for 100 mV input and 4-20 mA output. The **API 4380 DIN** powers the output loop, thus eliminating the need for an additional power supply. The 2000 V_{RMS} 3-way isolation of the module protects against unexpected common mode voltages, ground loops and electrical noise.

API maintains a constant effort to upgrade and improve its products. Specifications are subject to change without notice. Consult factory for your specific requirements.