

High Voltage Input DC to DC Isolator Transmitter

API 4380 G HV3



Input: Up to ± 200 VDC
Output: 0-1 V to ± 10 VDC or 0-2 mA to 4-20 mA

- One Minute Setup for Hundreds of I/O Ranges
- External Switches & Tables for Range Selection
- 2000 V Isolation Input/Output/Power
- Input and Output LoopTracker® LEDs
- Functional Test Pushbutton

Applications

- Isolate, Convert, Boost, Rescale Process Signals
- One Model to Interface Process Signals with Panel Meters, Recorders, Data Acquisition Cards, PLCs, DCS Systems, SCADA Systems

Specifications

Input Ranges

Consult factory for optional switch selectable ranges within I/O limits
 System voltages must not exceed socket voltage rating

Minimum Voltage: 0 to 1 VDC
 Maximum Voltage: 0 to 200 VDC
 Maximum Bipolar Voltage: ± 200 VDC

Input Impedance

Voltage: 1 M Ω minimum

LoopTracker

Variable brightness LEDs indicate input/output loop level and status

Output Ranges

	Minimum	Maximum	Load Factor
Voltage:	0-1 VDC	0-10 VDC	
Bipolar Voltage:	± 1 VDC	± 10 VDC	
Current (20 V compliance):	0-2 mADC	0-20 mADC	1000 Ω at 20 mA

Output Zero and Span

Multiturn potentiometers to compensate for load and lead variations
 $\pm 15\%$ of span adjustment range typical

Functional Test Button

Sets output to test level when pressed
 Potentiometer factory set to approximately 50% of span
 Adjustable 0-100% of span

Output Linearity

Better than $\pm 0.1\%$ of span

Output Ripple and Noise

Less than 10 mV_{RMS}

Response Time

Standard: 100 milliseconds typical
 High speed: 30 milliseconds typical with DF option

Isolation

2000 V_{RMS} minimum
 Full isolation: power to input, power to output, input to output

Ambient Temperature Range

-10°C to +60°C operating

Temperature Stability

Better than $\pm 0.02\%$ of span per °C

Power

Standard: 115 VAC $\pm 10\%$, 50/60 Hz, 2.5 W max.
A230 option: 230 VAC $\pm 10\%$, 50/60 Hz, 2.5 W max.
D option: 9-30 VDC, 2.5 W typical



Wide Ranging I/O
One Minute Setup!

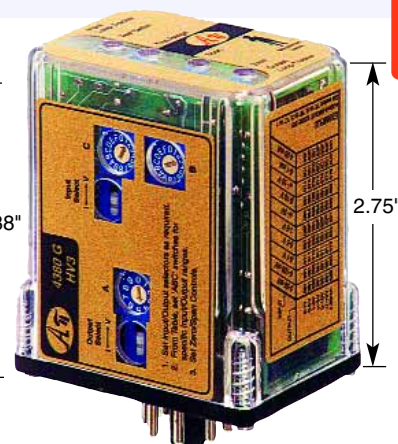
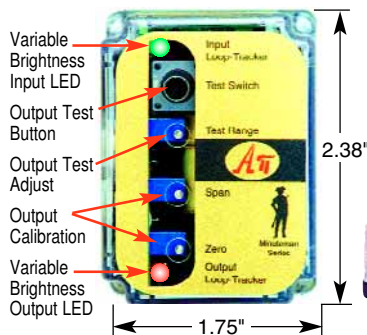

Description and Features

The **API 4380 G HV3** accepts a DC voltage input and provides an optically isolated DC voltage or current output that is linearly related to the input. This module is unique because it is field rangeable for voltage inputs to ± 200 VDC. Typical applications include signal isolation and signal conversion.

The optical isolation between input and output makes this module useful for ground loop elimination, common mode signal rejection or noise pickup reduction. The module power supply is isolated, resulting in full 3-way (input, output, power) isolation.

The **API 4380 G HV3** can be field-configured via external rotary and slide switches. Most common ranges are built-in, and can be selected from the table on the module, however virtually unlimited combinations are possible. Consult the factory for assistance with special ranges.

API exclusive features include two **LoopTracker** LEDs and a **Functional Test Pushbutton**. The LoopTracker LEDs (Green for input, Red for output) vary in intensity with changes in the process input and output signals. Monitoring the state of these LEDs can provide a quick visual picture of your process loop at all times.

The functional test pushbutton provides a fixed output (independent of the input) when held depressed. The test output level can be field-adjusted via a multiturn potentiometer. Both the LoopTracker LEDs and functional test pushbutton greatly aid in saving time during initial startup and/or troubleshooting.

The **API 4380 G HV3** plugs into an industry standard 8-pin octal socket sold separately. Sockets **API 008** and finger-safe **API 008 FS** allow either DIN rail or panel mounting.

Models & Options

API 4380 G HV3 Field rangeable high voltage input DC to DC isolated transmitter, 115 VAC

Options—Add to end of model number

A230	Powered by 230 VAC, 50/60 Hz
D	Powered by 9-30 VDC
DF	Fast response, 1 millisecond nominal response time
U	Conformal coating for moisture resistance

Accessories—Order as separate line item

API 008	8-pin socket
API 008 FS	8-pin finger-safe socket
API TK36	DIN rail, 35 mm W x 39" L, aluminum



1 Delta Park Blvd #12
 Brampton, ON L6T 5G1
 905-457-6322 or 800-794-5883
 www.mod-tronic.com

DC Input



Frequently Asked Questions

Do you recommend placing a fuse at the power input (115 VAC) for protection?

It is not required, but if desired, a 1/2 Amp Fast Blow fuse can be used for each module.

We are using many different types of your signal conditioners and wish to protect the inputs and outputs from short circuits and over voltage. How can we achieve this?

Applying a short circuit to any of the signal input terminals will not affect the modules. Exposing the signal input to high voltage will damage the unit but using a zener diode, due to its resistance value, will cause the input range to need recalibrating. Try a Varistor or TransZorb®. Do NOT under any circumstances short circuit the signal output, the unit can be damaged.

For modules with a 4-20 mA output signal, what are the minimum and maximum output load resistance?

For the units with a 20 V compliance, the output range is 10 to 1000 ohms.
For the units with a 12 V compliance, the output range is 10 to 600 ohms.

For the DC output models, what are the output impedances in the voltage and current mode?

The DC outputs are FET driven and are active outputs that change depending on the mode and range.

CURRENT Mode	VOLTAGE Mode	
DC output with 12 V Compliance	less than 600 ohms	greater than 1000 ohms
DC output with 20 V Compliance	less than 1000 ohms	greater than 1000 ohms

For your DC Input modules in the current mode, the input impedance rating is 50 ohms. For troubleshooting purposes, is that value the same with and without power applied to the module?

Yes.

TransZorb—Reg TM General Semiconductor

What is a Ground Loop?

In a process control loop, a ground loop circuit can develop when each device's ground is tied to a different earth potential thereby allowing current to flow between the grounds by way of the process loop (Figure 1).

Ground loops cause problems by adding or subtracting current or voltage from the process loop. This addition and/or subtraction causes the receiving device to be unable to differentiate between the wanted and unwanted signals and thus can't accurately reflect actual process signals.

The probability of multiple grounds and ground loops being established is especially high when new programmable logic controllers (PLCs) or distributed control systems (DCSs) are installed. With so many conditions within a facility referenced to ground, the likelihood of establishing more than one ground point is great. Thus, if an instrumentation system seems to be acting strangely or erratically, and the problem seems to point toward ground loops, the chore of eliminating all unintended ground connections becomes overwhelming.

Keep in mind that eliminating ground loops just isn't feasible for some instruments, such as thermocouples and some analyzers, because they require a ground to obtain accurate measurements. In addition, some instruments must be grounded to ensure personnel safety. When ground loops can't be eliminated, the solution lies in the use of signal isolators. These devices break the galvanic path (DC continuity) between all grounds while allowing the analog signal to continue throughout the loop. An isolator also can eliminate the electrical noise of AC continuity (common mode voltage).

Signal isolators can use numerous techniques to achieve their function but the best signal isolators usually employ optical isolators (Figure 2). Regardless of the isolation method used, an isolator must provide input, output, and power isolation. If this three-way isolation is not provided, then an additional ground loop can develop between the isolator's power supply and the process input and/or output signal.

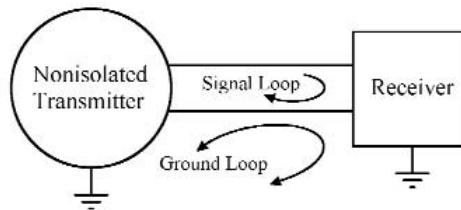

Figure 1. Ground loops may develop with non-isolated transmitters and receivers, resulting in inaccuracy and unreliability.

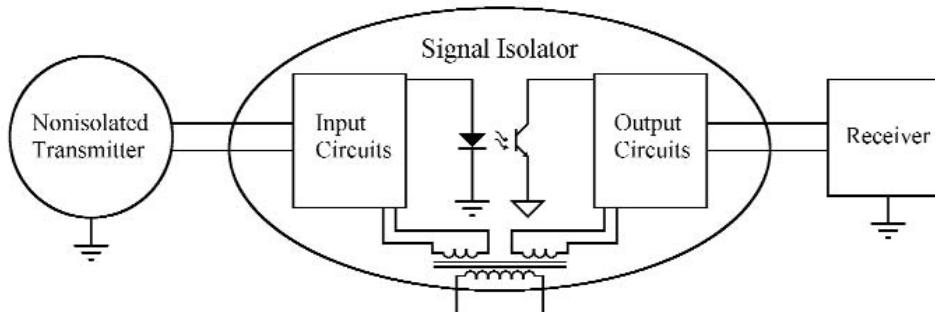

Figure 2. A signal isolator in the process loop blocks ground current to restore signal accuracy and reliability.

API maintains a constant effort to upgrade and improve its products. Specifications are subject to change without notice. Consult factory for your specific requirements.