

DC to Frequency Field Rangeable Isolator/Transmitter

API 7500 G

Input: 0-50 mV to ± 10 VDC, 0-1 mA to 4-20 mA DC
Output: 0-100 Hz to 0-30 kHz MOSFET or TTL

- 24 Selectable Inputs & 30 Selectable Outputs
- Setup via Rotary Switches & Easy-to-use Tables
- 2000 V Full Isolation Input/Output/Power
- Adjustable Low Frequency Cutout
- Input and Output LoopTracker® LEDs
- Functional Test Pushbutton

Applications

- Analog to Frequency for Totalizers & Counters
- Use With API 7010 G for Remote Monitoring

Specifications

Input Ranges

Voltage: 0-50 mVDC to ± 10 VDC
 Current: 0-1 mA DC to 0-20 mA DC including 4-20 mA
 Consult factory for other ranges
 System voltages must not exceed socket voltage rating

Input Impedance

Voltage: 1 M Ω minimum Current: 50 Ω typical

Input Loop Power Supply

18 VDC nominal, unregulated, 25 mA DC, max. ripple, less than 1.5 V_{p-p}

LoopTracker

Variable brightness LEDs indicate input/output loop level and status

Output Ranges

	Minimum	Maximum	Range Increments
Low range:	0-100 Hz	0-1500 Hz	100 Hz
High range:	0-2 kHz	0-30 kHz	2 kHz

Output Driver

Open drain MOSFET, 24 VDC maximum
 I_{sink} 50 mA maximum
 V_{on} 0.6 V maximum at 50 mA I_{sink}
 Optional 9 V_{p-p} TTL output, specify M02 option

Output Linearity

Better than $\pm 0.4\%$ of span

Cutout Control

Disables output when input falls below preset level
 Adjustable from 2% to 25% of range
 Top accessible, multi-turn potentiometer.

Output Zero and Span

Multiturn potentiometers to compensate for load and lead variations
 $\pm 15\%$ of span adjustment range typical

Functional Test Button

Sets output to test level when pressed
 Potentiometer factory set to approximately 50% of span
 Adjustable 2% to 100% of span

Response Time

70 milliseconds typical
 Consult factory for faster response times

Isolation

2000 V_{RMS} minimum
 Full isolation: power to input, power to output, input to output

Ambient Temperature Range

-10°C to +60°C operating

Temperature Stability

Better than $\pm 0.02\%$ of span per °C

Power

Standard: 115 VAC $\pm 10\%$, 50/60 Hz, 2.5 W max.
 A230 option: 230 VAC $\pm 10\%$, 50/60 Hz, 2.5 W max.
 D option: 9-30 VDC, 1.5 W typical

© Absolute Process Instruments, Inc. 11/04 LoopTracker—Reg TM Absolute Process Instruments, Inc.



Wide Ranging I/O
One Minute Setup!

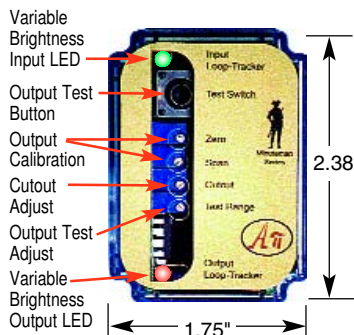

Free Factory Input & Output Calibration!

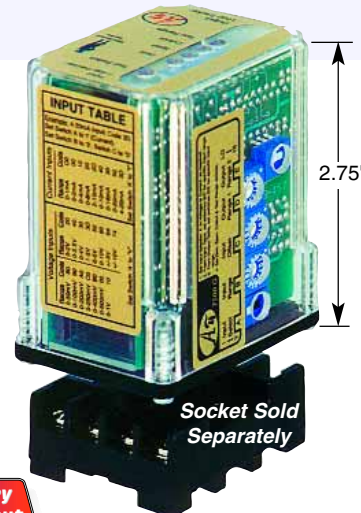

Frequency



Description and Features

The API 7500 G accepts a DC voltage or current input and provides an optically isolated frequency output that is directly proportional to the input. Common applications include pulse counting or totalizing of DC process signals from devices such as flow transmitters, analog signal transmission over long distances, or analog inputs into PLCs. The full 3-way (input, output, power) isolation makes this module useful for ground loop elimination, common mode signal rejection or noise pickup reduction.

A low frequency cutout potentiometer can be adjusted to disable the output when the input falls below a pre-determined level. The API 7500 G can be field-configured via external rotary and slide switches. Common ranges are on the module label, however, virtually unlimited combinations are possible. Consult the factory for assistance with special ranges.

The API 7500 G has an open drain MOSFET (open collector) output which requires a user supplied external power supply and pull-up resistor allowing the module to be interfaced with a wide variety of devices. For a 9 V_{p-p} powered output, order model API 7500 G M02.

API exclusive features include two LoopTracker LEDs and a Functional Test Pushbutton. The LoopTracker LEDs (Green for input, Red for output) vary in intensity with changes in the process input and output signals. Monitoring the state of these LEDs can provide a quick visual picture of your process loop at all times. The functional test pushbutton provides a fixed output (independent of the input) when held depressed. The test output level can be field-adjusted via a multiturn potentiometer.

Both the LoopTracker LEDs and functional test pushbutton greatly aid in saving time during initial startup and/or troubleshooting. The built-in 18 VDC unregulated loop excitation power supply can be used to power passive input devices.

Models & Options

API 7500 G Field rangeable DC to frequency transmitter, isolated, with loop power supply, 115 VAC

Options—Add to end of model number

- A230** Powered by 230 VAC, 50/60 Hz
- D** Powered by 9-30 VDC
- M02** TTL 9 V_{p-p} powered output instead of MOSFET output
- U** Conformal coating for moisture resistance

Accessories—Order as separate line item

- API 008** 8-pin socket
- API 008 FS** 8-pin finger-safe socket
- API TK36** DIN rail, 35 mm W x 39" L, aluminum



1 Delta Park Blvd #12
 Brampton, ON L6T 5G1
 905-457-6322 or 800-794-5883
 www.mod-tronic.com



ELECTRICAL CONNECTIONS

WARNING! All wiring must be performed by qualified personnel only. This module requires an industry-standard 8-pin socket. Order API 008 or finger-safe API 008 FS socket separately.

Power Input Terminals – The white label on the side of the API module will indicate the power requirements. AC power is connected to terminals 1 and 3. For DC powered modules, polarity **MUST** be observed. Positive (+) is wired to terminal 1 and negative (–) is wired to terminal 3.

Powered Signal Input – Observe polarity when connecting the signal input. The positive signal (+) is wired to terminal 5 and negative (–) to terminal 6.

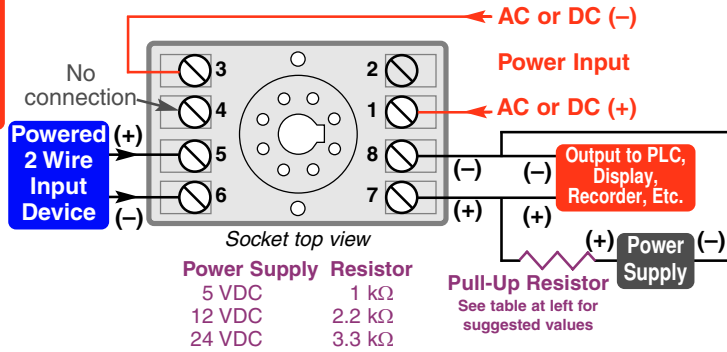

API 7500 G typical wiring with powered input and standard output

Passive Signal Input Using the 18 V Supply – Polarity must be observed when connecting the signal input. A passive input device can be powered by the 18 volt DC power supply at terminal 4 (+) and terminal 5 (–). This may save the expense of purchasing a separate power supply for the input device. A typical example is shown, however consult the manufacturer of your specific sensor to determine its compatibility and proper wiring.

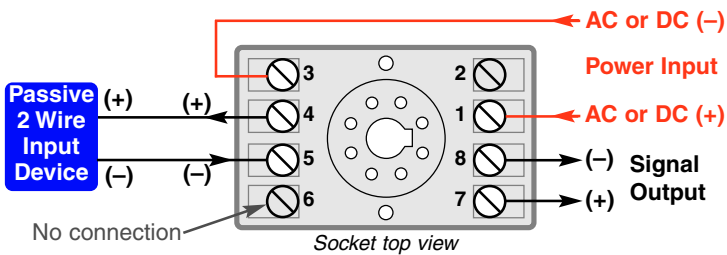

Using the built-in 18 VDC loop supply to power a passive input device

Signal Output Terminals – Polarity must be observed when connecting the signal output to the load. The positive connection (+) is connected to terminal 7 and the negative (–) is connected to terminal 8. The API 7500 G has an open drain MOSFET (open collector) output requiring a user-supplied external power supply and pull-up resistor.

API 7500 G M02 – This model has a 9 V_{p-p} TTL powered output and requires no external power supply or pull up resistor. Frequency output is a fixed amplitude of 9 VDC peak to peak with a maximum current drive capability of 10 mA.

RANGE SELECTION

Three rotary switches and two slide switches located on the side of the module are used to select input and output ranges. Most popular ranges are listed on the module labels. See www.api-usa.com or contact factory for special ranges.

1. Set the **Input Select** slide switch to current (I) or voltage (V) depending on input type. The input selector switch determines the input impedance for the module, typically 50 Ω for current inputs and 1 MΩ or greater for voltage.
2. From the table, find the rotary switch settings that match your input range and set **Input Range “B”** and **Input Offset “C”**.
3. From the table, find your frequency range and set **Output Range 2 “E”** to HI or LO and set **Output Range 1 “D”** to match your frequency output range.

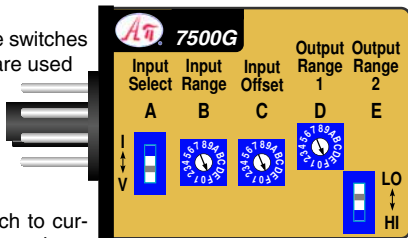

CALIBRATION

Input and output ranges are pre-configured at the factory as specified on your order. Top-mounted, Zero and Span potentiometers can be used should fine-tuning be necessary. Custom ranges may require factory modification.

1. Apply power to the module and allow a minimum 20 minute warm up time.
2. Using an accurate frequency calibration source, provide an input to the module equal to the minimum input required for the application.
3. Using an accurate measurement device for the output, adjust the Zero potentiometer for the exact minimum output desired. The Zero control should only be adjusted when the input signal is at its minimum. This will produce the corresponding minimum output signal of 0 Hz.
4. Set the input at maximum, and then adjust the Span pot for the exact maximum output desired. The Span control should only be adjusted when the input signal is at its maximum. This will produce the corresponding maximum output signal.
5. Repeat adjustments for maximum accuracy.

Cutoff Control – This multi-turn potentiometer provides the user with a threshold adjustment. The Input signal must overcome this setting to produce an Output from the unit.

Test Range Adjust – Turn the multi-turn Test Range potentiometer while holding the Test button depressed until the desired output test level is reached.

OPERATION

Depending on the rotary switch settings, the input is filtered, either amplified or attenuated as required, then passed through an optical isolation circuit to the output stage.

Test Button – The Test pushbutton may be set to provide the desired output when depressed. This will drive the device on the output side of the loop (a panel meter, chart recorder, etc.) with a known good signal that can be used as a system diagnostic aid during initial start-up or during troubleshooting. It can be adjusted to vary the output signal from 0 to 100% of the calibrated output range. When released, the output will return to normal.

GREEN LoopTracker® Input LED – Provides a visual indication that a signal is being sensed by the input circuitry of the module. It also indicates the input signal strength by changing in intensity as the process changes from minimum to maximum. If the LED fails to illuminate, or fails to change in intensity as the process changes, this may indicate a problem with module power or signal input wiring.

RED LoopTracker Output LED – Provides a visual indication that the output signal is functioning. It becomes brighter as the input and the corresponding output change from minimum to maximum. For current outputs, the RED LED will only light if the output loop current path is complete. For either current or voltage outputs, failure to illuminate or a failure to change in intensity as the process changes may indicate a problem with the module power or signal output wiring.

VOLTAGE Inputs Switch A To “V”		CURRENT Inputs Switch A To “I”		Frequency Outputs			
Range	B C	Range	B C	Range	D E	Range	D E
0-50 mV	8 0	0-1 mA	C 0	0-100 Hz	1 LO	0-2 kHz	1 HI
0-100 mV	9 0	0-2 mA	0 0	0-200 Hz	2 LO	0-4 kHz	2 HI
0-200 mV	A 0	0-4 mA	1 0	0-300 Hz	3 LO	0-6 kHz	3 HI
0-250 mV	C 0	0-8 mA	2 0	0-400 Hz	4 LO	0-8 kHz	4 HI
0-400 mV	B 0	2-10 mA	2 D	0-500 Hz	5 LO	0-10 kHz	5 HI
0-500 mV	0 0	0-10 mA	4 0	0-600 Hz	6 LO	0-12 kHz	6 HI
0-1 V	1 0	0-16 mA	3 0	0-700 Hz	7 LO	0-14 kHz	7 HI
0-2 V	2 0	0-20 mA	5 0	0-800 Hz	8 LO	0-16 kHz	8 HI
0-2.5 V	4 0	4-20 mA	3 D	0-900 Hz	9 LO	0-18 kHz	9 HI
0-4 V	3 0			0-1000 Hz	A LO	0-20 kHz	A HI
1-5 V	3 D			0-1100 Hz	B LO	0-22 kHz	B HI
0-5 V	5 0			0-1200 Hz	C LO	0-24 kHz	C HI
0-10 V	6 0			0-1300 Hz	D LO	0-26 kHz	D HI
±5 V	6 4			0-1400 Hz	E LO	0-28 kHz	E HI
±10 V	7 4			0-1500 Hz	F LO	0-30 kHz	F HI

API maintains a constant effort to upgrade and improve its products. Specifications are subject to change without notice. Consult factory for your specific requirements.

Monitoring and Totalizing Flow

PROBLEM:

Add a totalizer to a process flow monitoring system.

SOLUTION:

An **API 7500 G M02** Field Selectable Isolated DC to Frequency Transmitter module is inserted in the 4-20 mA loop between the turbine flow meter and the chart recorder.

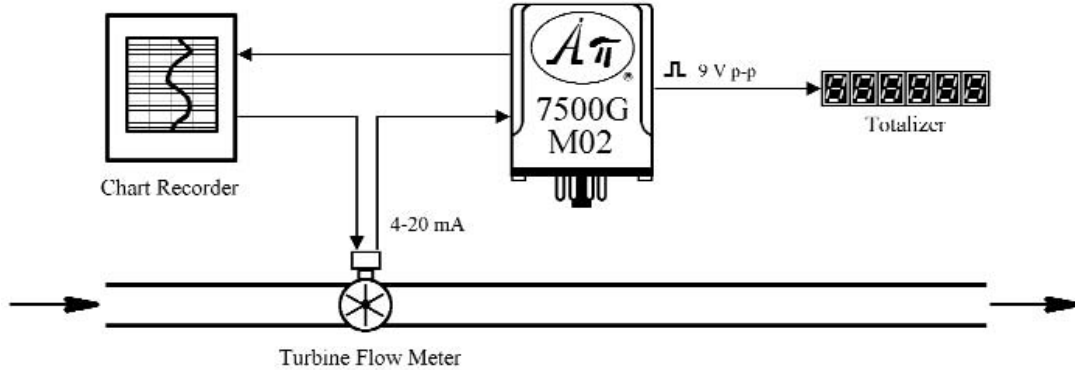

The **API 7500 G M02** provides the 9 V p-p square wave required by the totalizer system.

Monitoring and Totalizing Flow Meter Output

PROBLEM

The frequency output signal of a flow meter must be monitored by a DCS as well as a remotely located counter/totalizer. The counter/totalizer accepts a TTL frequency input.

SOLUTION

An **API 7580 G** Isolated Frequency to DC Transmitter module is connected to the frequency output of the flow meter. The **API 7580 G** has a built-in loop power supply to power the current loop.

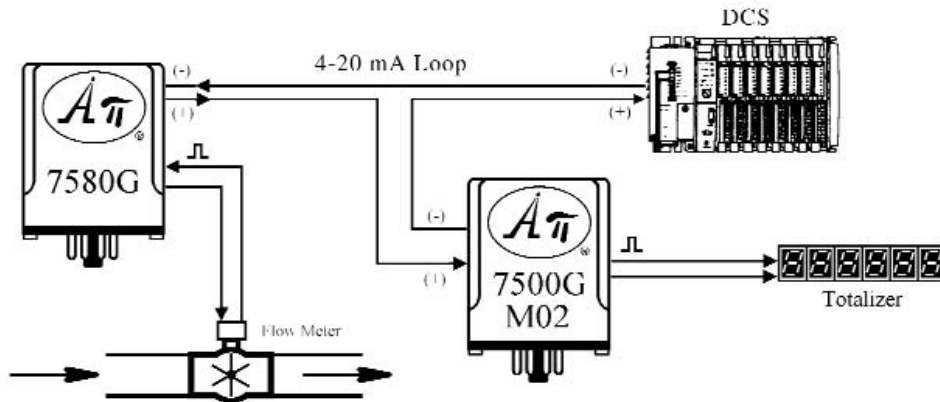

The **7580 G** converts the frequency to a 4-20 mA output which is sent to the DCS and an **API 7500G M02** mounted near the remote counter/totalizer. The **API 7500 G M02** converts the 4-20 mA signal to a TTL frequency signal for the counter/totalizer.

FREE APPLICATION ASSISTANCE
 Call  Customer Service
800-794-5883

MOD-TRONIC
 INSTRUMENTS LIMITED

1 Delta Park Blvd #12
 Brampton, ON L6T 5G1
 905-457-6322 or 800-794-5883
 www.mod-tronic.com



Monitoring Mixer Speed at a Remote Computer

PROBLEM

The speed of a mixing machine must be monitored by a computer located 1500 feet away, across an electrically noisy area. The tachometer on the mixer produces 24 pulses per revolution at 15 V peak-to-peak and the mixer runs at speeds up to 50 RPM. The computer input accepts a frequency of 0-1000 Hz at 5 V peak-to-peak.

SOLUTION

Api signal conditioning is applied at the tachometer output and at the computer input to provide noise immunity and signal compatibility.

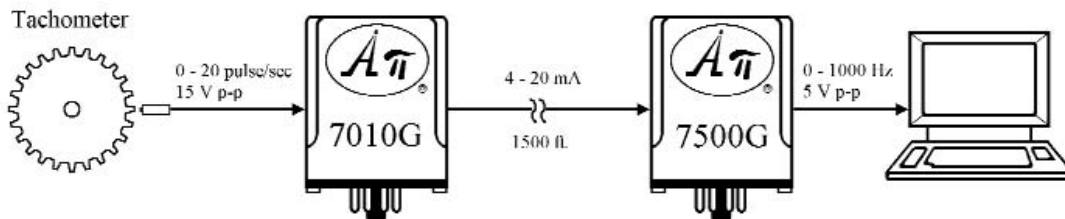

The tachometer output (24 pulse/rev x 50 rev/min x 1 min/60 sec = 20 pulse/sec) is converted to a 4-20 mADC signal by the **API 7010 G** Isolated Frequency to DC Transmitter module. At the computer, the 4-20 mADC signal is converted by the **API 7500 G** Field Selectable Isolated DC to Frequency Transmitter module to a frequency of 0-1000 Hz.

Frequently Asked Questions

Do you have a product that can provide an output signal of 5 KHz, 50% duty cycle, 20 mA max and 24 V_{p-p} max with no input?

Yes, the **API 7500G M03**.

Can you provide a module that will generate an output frequency (square wave) that we can vary between 55 and 75 Hz with no input signal?

Yes. Our **API 7500 G M03** with a modification to utilize the test circuit that is adjustable with the test range potentiometer. The test circuit is disabled internally and is always on. With the span pot set to the middle of the range, adjust the test range pot to give an output of 65 Hz which is the center point for 55-75 and serves to orient the window. Then, use the span pot to adjust the output frequency from 55 to 75 (the window is actually about 40 Hz). The zero pot and the cutout pot are disabled and have no effect.

We have a 4-20 mA signal and want to convert it to a pulsed output of 0-270 pulses/minute so we can drive a counter. Can you do this?

Yes. Convert the output to Hertz (cycles/second) so $270 / 60 = 4.5$ Hz. Our **API 7500 G SS** has an output range of 0-5 Hz and the span pot can adjust down by 10 % to allow for 0-4.5 Hz. The counter, which will trip on either rising or falling edges, can be set up to count at the edge of each cycle (square wave).

We have an application which requires a signal conversion of 1/2 Hz to 6 Hz input to a DC output. Do you have a signal conditioner to do this?

No. The minimum input frequency range that we offer is 0 to 15 Hz.

API Sockets API 008 and API 008 FS

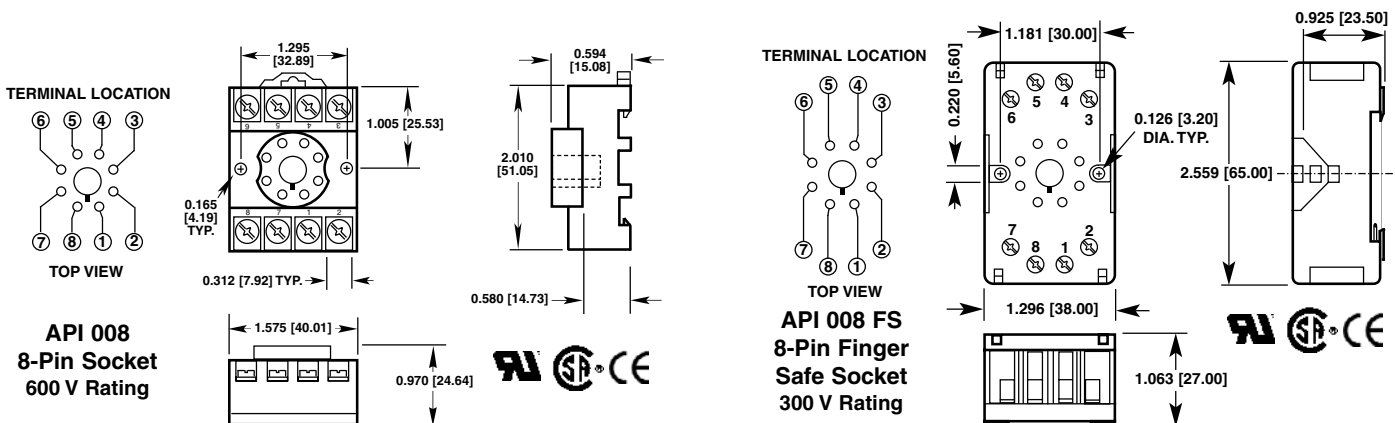

API maintains a constant effort to upgrade and improve its products. Specifications are subject to change without notice. Consult factory for your specific requirements.