

# Frequency to DC Alarm Trips Field Adjustable Setpoints

**API 1700 G**  
**API 1720 G**



**Input:** 0-10 Hz to 0-20 kHz  
**Output:** One DPDT Relay or Two SPDT Relays

- Wide Range of Input Frequencies
- 2 Fully Independent Setpoints on API 1720 G
- Input LoopTracker® and Alarm Status LEDs
- High Capacity 7 Amp Relay Contacts

## Applications

- Machinery Speed Hi or Lo Alarm
- Redundant or Backup Alarm
- Alert Users to Machine Malfunction

## Specifications

### Input Range

Factory Configured—Please specify input range

Minimum: 0-10 Hz  
Maximum: 0-20 kHz

### Input Impedance (Voltage)

100 kΩ minimum

### Input Protection

Normal Mode: 200% of input rating  
Common Mode: 600 VDC or 600 VAC<sub>p</sub> input to ground  
*System voltages must not exceed socket voltage rating.*

### Input Amplitude Range

100 mV<sub>RMS</sub> to 150 V<sub>RMS</sub>

### LoopTracker®

Variable brightness LED indicates input level and status

### Relay Output

Factory Configured—See Options for other relay configurations

**API 1700 G** One DPDT contact set  
HI alarm, normal action (failsafe), non-latching standard  
7 A @ 240 VAC maximum resistive load  
3.5 A @ 240 VAC maximum inductive load

**API 1720 G** Two SPDT contacts  
HI/LO, normal action (failsafe), non-latching standard  
7 A @ 240 VAC maximum resistive load  
3.5 A @ 240 VAC maximum inductive load

**CAUTION:** Socket contacts may limit system rating.  
External contact protection such as an RC snubber is recommended for inductive loads.

### Setpoint

12 turn potentiometer adjustable from 0 to 100% of span

### Deadband

**API 1700 G** 1.0 to 100% of span, 12 turn potentiometer

**API 1720 G** Fixed at 1% of span, standard

**API 1720 GA** 1.0 to 100% of span, 1 turn potentiometer

### Functional Test/Reset Button

Toggle relay(s) to opposite state when pressed  
Resets latching relay on 1700 G with HT option

### Response Time

70 milliseconds typical

### Ambient Temperature Range

-10°C to +60°C operating

### Temperature Stability

Better than ±0.02% of span per °C

### Power

Standard: 115 VAC ±10%, 50/60 Hz, 2.5 W max.

**A230** option: 230 VAC ±10%, 50/60 Hz, 2.5 W max.

**D** option: 9-30 VDC, 2.5 W typical

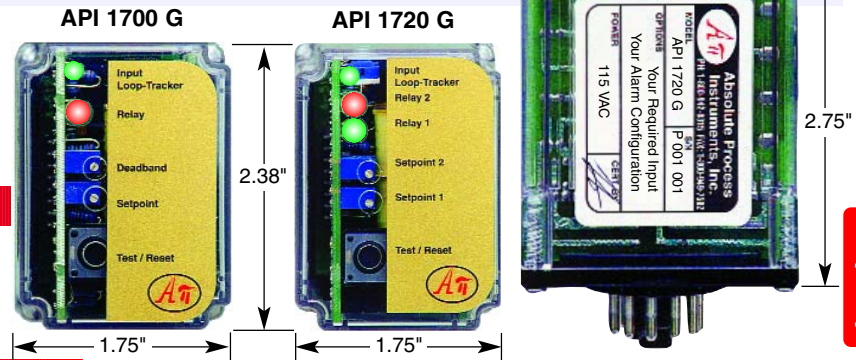

## Description and Features

The **API 1700 G** and **API 1720 G** are factory configured for a frequency input and provide alarm contact outputs. Heavy-duty relay contacts allow the module to directly control high capacity loads.

API exclusive features include a **LoopTracker®** LED which varies in intensity with changes in the process signal, alarm status LEDs for each alarm, and a **Functional Test Pushbutton** to toggle the relays independent of the input.

The **API 1700 G** provides a single setpoint adjustment and DPDT relay contacts. The alarm output can be factory configured for HI or LO operation, non-latching or latching, normal (fail-safe) or reverse (non-fail-safe) acting.

The **API 1720 G** contains two independent setpoints with two SPDT relay contact outputs. The alarm output can be factory configured for HI/HI, HI/LO, LO/HI or LO/LO operation, normal acting (fail-safe) or reverse acting (non-fail-safe).

The **API 1700 G** and **API 170 G** plug into an industry standard 8-pin octal socket sold separately. Sockets **API 011** and finger-safe **API 011 FS** allow either DIN rail or panel mounting.

## Models & Options

Factory Configured—Please specify input range

**API 1700 G** Frequency input alarm trip, 1 DPDT relay, HI alarm, normal action (failsafe), non-latching, 115 VAC

**API 1720 G** Frequency input dual alarm trip, 2 SPDT relays, HI/LO, normal action (failsafe), non-latching, 115 VAC

Options—Add to end of model number

**A230** Powered by 230 VAC, 50/60 Hz

**D** Powered by 9-30 VDC

**A** Adjustable deadbands for 1720 G

**HT** Latching alarm with pushbutton reset, API 1700 G only

**HP** Latching alarm with power-off reset, API 1700 G only

**R** Reverse-acting alarms (non-failsafe)

**L** Low trip (on decreasing signal) for 1700 G

**HH** High/High trip for 1720 G instead of High/Low

**LL** Low/Low trip for 1720 G instead of High/Low

**U** Conformal coating for moisture resistance

Accessories—Order as a separate line item

**API 011** 11-pin socket

**API 011 FS** 11-pin finger safe socket

**API TK36** DIN rail, 35 mm W x 39" L, aluminum

**MOD-TRONIC**  
INSTRUMENTS LIMITED

1 Delta Park Blvd #12  
Brampton, ON L6T 5G1  
905-457-6322 or 800-794-5883  
www.mod-tronic.com



### ELECTRICAL CONNECTIONS

**WARNING!** All wiring must be performed by qualified personnel only. This module requires an industry-standard 11-pin socket. Order API 011 or finger-safe API 011 FS socket separately.

**Power Input Terminals** – The white label on the side of the API module will indicate the power requirements. AC power is connected to terminals 1 and 3. For DC powered modules, polarity **MUST** be observed. Positive (+) is wired to terminal 1 and negative (-) is wired to terminal 3.

**Signal Input** – Polarity must be observed when connecting the signal input. The positive connection (+) is applied to terminal 4 and the negative (-) is applied to terminal 5.

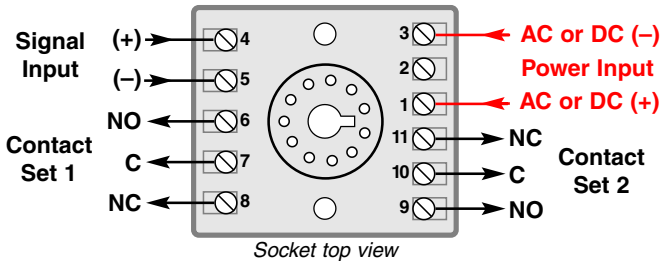

**Relay Output Terminals** – Terminals 6, 7, 8 and 9, 10, 11 provide the appropriate connections for the desired relay operations. (NO = Normally Open, NC = Normally Closed, C = Common). NOTE: Although the API 1700 G has a pair of relays, these relays will energize and de-energize in unison. The API 1720 G will accommodate independent relay operations.

### SETUP

The input range and alarm types are pre-configured at the factory as specified on your order. No input calibration is necessary. Contact factory for custom ranges or modifications.

**Setpoint Control** – This multi-turn potentiometer (one for each setpoint on the API 1720 G) allows the operator to adjust the level at which the alarm is activated. This control is adjustable from 0 to 100% of the input range.

**Deadband Control** – The API 1700 G deadband potentiometer allows the alarm trip and reset window to be adjusted symmetrically about the setpoint from 1 to 100% of the span.

The deadband is fixed at 1% of span on the API 1720 G. The API 1720 GA with adjustable deadband option allows deadbands to be adjusted symmetrically about each setpoint from 1 to 100% of the span.

Adjustable deadband allows the operator to fine tune the point at which the alarm trips (alarm condition) and resets (non alarm condition). The deadband is typically used to prevent chattering of the relays or false trips when the process signal is unstable or changes rapidly.

**API 1720 G Alarm Configuration** – The alarm configuration of the API 1720 G is pre-configured at the factory per your order, but if a change is necessary, internal jumpers can be used to modify the alarm type as follows.

1. Unplug the module from the socket.
2. Remove the 4 screws from the module bottom and remove the plastic case.
3. Unplug the circuit board with the test button from the base.
4. Note location of jumper block at top left of circuit board next to test button.
5. Place jumpers as indicated for desired alarm operation. The standard HI/LO setting is with one jumper across the two top pins or with no jumper at all. Never place a jumper across the two bottom pins!
6. Replace board, cover, and screws.

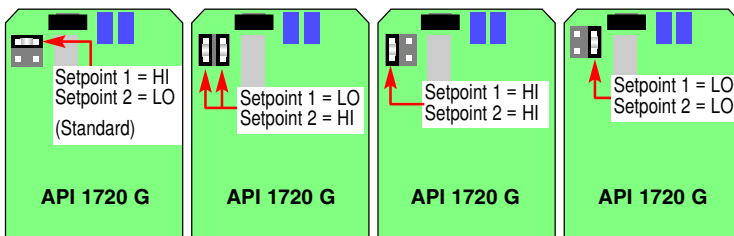

### TEST SWITCH

The functional test pushbutton toggles the alarm status independent of the input when depressed. It verifies the alarm and system operation and also provides the additional function of unlatching the alarm on the API 1700 GHT with the latching alarm option.

### OPERATION

**GREEN LoopTracker® Input LED** – Provides a visual indication that a signal is being sensed by the input circuitry of the module. It also indicates the input signal strength by changing in intensity as the process changes from minimum to maximum to provide a quick visual picture of your process loop at all times. If the LED fails to illuminate, or fails to change in intensity as the process changes, this may indicate a problem with module power or signal input wiring. This features greatly aid in saving time during initial start-up or troubleshooting.

**Bi-Color Alarm LED** – Provides a visual indication of the alarm status. In all configurations, a GREEN LED indicates a non-alarm condition and a RED LED indicates an alarm condition.

**Alarm Relays** – In the normal mode of operation (failsafe), the relay coil is energized in a non-alarm condition and de-energized in an alarm condition. This will create an alarm condition if the module loses power. For a normal acting, non-latching configuration, the alarm will activate when the input signal exceeds the setpoint (HI alarm) or falls below the setpoint (LO alarm), then will automatically reset when the alarm condition no longer exists.

If reverse acting mode is selected (non-failsafe), the relay coil is de-energized in a non-alarm condition and energized in an alarm condition. The alarm will activate when the input signal exceeds the setpoint (HI alarm) or falls below the setpoint (LO alarm), then will automatically reset when the alarm condition no longer exists.

**API 1700 GHT Latching Alarm** – For units with the HT latching alarm option, the Test Switch is also used to reset the alarm relays. The alarm relay contacts will remain in the alarmed condition until the input signal falls below the high alarm setpoint (or above low alarm setpoint, depending on configuration) and the Test/Reset pushbutton has been pressed or power to the unit has been switched off.

**API 1700 GHP Latching Alarm** – For units with the HP latching alarm option, the alarm relay contacts will remain in the alarmed condition until the input signal falls below the high alarm setpoint (or above low alarm setpoint, depending on configuration) and the power to the unit has been switched off.

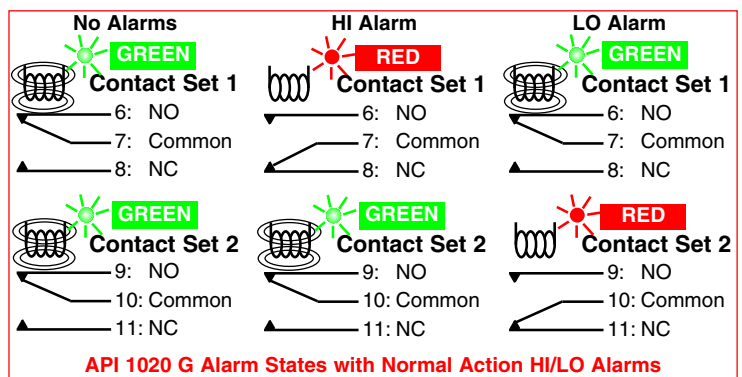
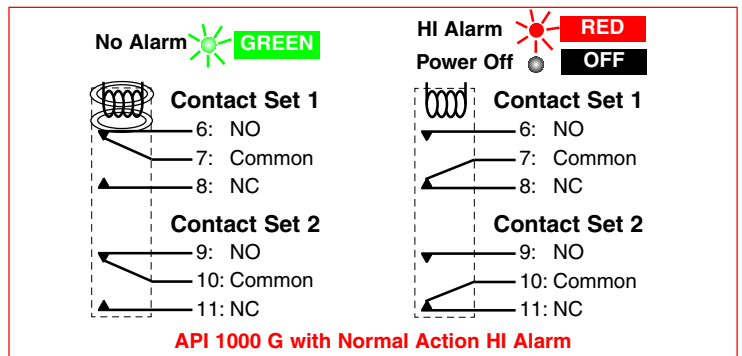

Frequency

# Frequency to DC Transmitter/Isolator



**Input:** 0-25 Hz to 0-20 kHz  
**Output:** 0-1 V to  $\pm 10$  VDC or 0-1 mA to 4-20 mA

- Precision Frequency to DC Converter
- Input and Output LoopTracker® LEDs
- Full 2000 VRMS Input/Output/Power Isolation
- Functional Test Pushbutton

## Applications

- Monitor and Control Motor or Line Speed
- Convert a Square Wave Output to 4-20 mA
- Simplify Interfacing of Frequency Type Devices

## Specifications

### Input Range

Factory Configured—Please specify input range

	Minimum	Maximum
Frequency:	0-25 Hz	0-20 kHz
Voltage:	100 mVRMS	150 VRMS

### Input Waveform

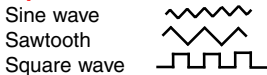

Most other waveforms with greater than 100 mV amplitude change

### Input Impedance

100 k $\Omega$  minimum

### Input Protection

Normal mode: 200% of input rating  
 Common mode: 600 VDC or 600 VAC<sub>p</sub> input to ground  
 System voltages must not exceed socket voltage rating

### Input Loop Power Supply

18 VDC nominal, unregulated, 25 mADC  
 Maximum ripple, less than 1.5 V<sub>p-p</sub>

### LoopTracker

Variable brightness LEDs indicate input/output loop level and status

### Output Range

Factory Configured—Please specify output range

	Minimum	Maximum	Load Factor
Voltage:	0-1 VDC	0-10 VDC	
Bipolar Voltage:	$\pm 1$ VDC	$\pm 10$ VDC	
Current (20 V compliance):	0-2 mADC	0-20 mADC	1000 $\Omega$ at 20 mA

Consult factory for other ranges

### Output Linearity

Better than  $\pm 0.1\%$  of span

### Response Time

70 milliseconds typical

### Output Zero and Span

Multiturn potentiometers to compensate for load and lead variations.  $\pm 15\%$  of span adjustment range typical.

### Functional Test Button

Sets output to test level when pressed.  
 Factory set to approximately 50% of span

### Isolation

2000 V<sub>RMS</sub> minimum  
 Full isolation: power to input, power to output, input to output

### Ambient Temperature Range and Temperature Stability

$-10^{\circ}\text{C}$  to  $+60^{\circ}\text{C}$  operating ambient  
 Better than  $\pm 0.02\%$  of span per  $^{\circ}\text{C}$  stability

### Power

Standard: 115 VAC  $\pm 10\%$ , 50/60 Hz, 2.5 W max.  
**A230** option: 230 VAC  $\pm 10\%$ , 50/60 Hz, 2.5 W max.  
**D** option: 9-30 VDC, 2.5 W typical

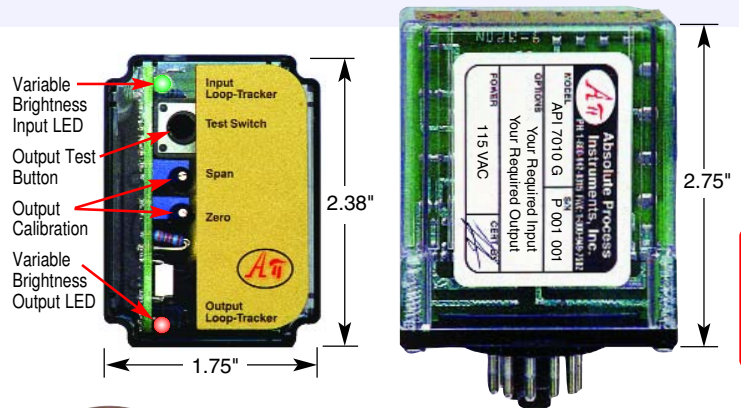

## Description and Features

The **API 7010 G** accepts a frequency input and provides an optically isolated DC voltage or current analog output that is linearly proportional to the input. The full 3-way (input, output, power) isolation between input and output makes this module useful for ground loop elimination, common mode signal rejection or noise pickup reduction.

Common applications include frequency to DC conversions from frequency output type devices such as rotary encoders, magnetic pick-ups, variable speed drives and flow meters. For PLCs that do not have analog outputs, often the pulse rate of a discreet output can be programmed to vary. By connecting the **API 7010 G** to this output, a proportional analog signal can be generated.

API exclusive features include two **LoopTracker** LEDs and a **Functional Test Pushbutton**. The LoopTracker LEDs (Green for input, Red for output) vary in intensity with changes in the process input and output signals. Monitoring the state of these LEDs can provide a quick visual picture of your process at all times. The functional test pushbutton provides a fixed output (independent of the input) when held depressed. The test output level is fixed at 50% of output span. Both the LoopTracker LEDs and functional test pushbutton greatly aid in saving time during initial startup and/or troubleshooting.

Also standard on the **API 7010 G** is an 18 VDC unregulated loop excitation supply. This supply can be used to power passive input devices, often eliminating the need for an additional external power supply.

The **API 7010 G** plugs into an industry standard 8-pin octal socket sold separately. Sockets **API 008** and finger-safe **API 008 FS** allow either DIN rail or panel mounting.

## Models & Options

Factory Configured—Please specify input and output ranges

**API 7010 G** Frequency to DC transmitter, isolated, with loop power supply, 115 VAC

Options—Add to end of model number

<b>A230</b>	Powered by 230 VAC, 50/60 Hz
<b>D</b>	Powered by 9-30 VDC
<b>HC</b>	High current output, >20 mA to 50 mADC
<b>EXTSUP</b>	Open collector output when a "sinking" output is required
<b>U</b>	Conformal coating for moisture resistance

Accessories—Order as a separate line item

<b>API 008</b>	8-pin socket
<b>API 008 FS</b>	8-pin finger safe socket
<b>API TK36</b>	DIN rail, 35 mm W x 39" L, aluminum



1 Delta Park Blvd #12  
 Brampton, ON L6T 5G1  
 905-457-6322 or 800-794-5883  
 www.mod-tronic.com



### RANGES

The input and output ranges are pre-configured at the factory as specified on your order. No input calibration is necessary. Consult factory for other available ranges or for special ranges.

When a current output is ordered, it provides power to the output current loop (sourcing). If an unpowered (sinking) current output is required, order the API 7010 G EXTSUP with open collector output.

### ELECTRICAL CONNECTIONS

**WARNING!** All wiring must be performed by qualified personnel only. This module requires an industry-standard 8-pin socket. Order API 008 or finger-safe API 008 FS socket.

**Power Input Terminals** – The white label on the side of the API module will indicate the power requirements. AC power is connected to terminals 1 and 3. For DC powered modules, polarity **MUST** be observed. Positive (+) is wired to terminal 1 and negative (-) is wired to terminal 3.

**Powered Signal Input** – Polarity must be observed when connecting the signal input. The positive connection (+) is applied to terminal 5 and the negative (-) is applied to terminal 6.

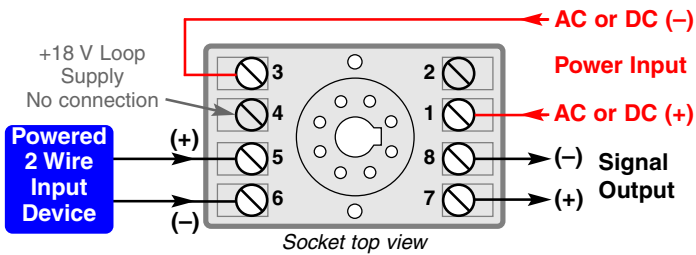

Connecting an input device which provides power to the input circuit

**Passive Signal Input** – Polarity must be observed when connecting the signal input. A passive input device can be powered by the 18 volt DC power supply at terminal 4. This may save the expense of purchasing a separate power supply for the input device. A typical example is shown, however it is very important to consult the manufacturer of your specific sensor to determine its compatibility and proper wiring.

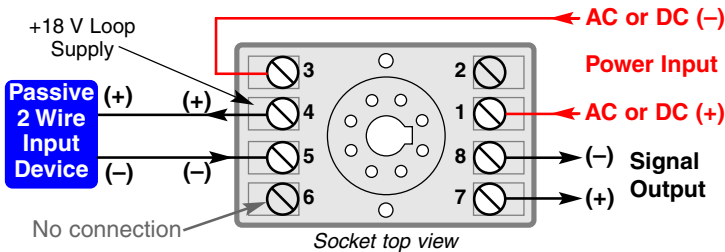

Using the built-in 18 VDC loop supply to power a passive input device

**Signal Output Terminals** – Polarity must be observed when connecting the signal output to the load. The positive connection (+) is connected to terminal 7 and the negative (-) is connected to terminal 8. When a current output is ordered, it provides power to the output current loop (sourcing). If an unpowered (sinking) current output is required, order the API 7010 G EXTSUP with open collector output.

### TEST BUTTON

The Test Switch pushbutton may be used to drive the device on the output side of the loop (a panel meter, chart recorder, etc.) with a known good signal that can be used as a system diagnostic aid during initial start-up or during troubleshooting. This test signal is factory set to approximately 50% of the calibrated output range. When the button is released, the output will return to normal.

Example: If you are checking a 4-20 mA current loop, when the pushbutton is held depressed, the output from the module will be approximately 12 mA.

### OPERATION

The frequency input to the API 7010 G is filtered to remove unwanted noise, converted to a DC voltage, and then passed through an opto-coupler to the output stage.

The frequency input can be virtually any type of signal (sine wave, sawtooth, square wave, etc.) as long as there is a sufficient change in amplitude (greater than 100mV).

**GREEN LoopTracker® Input LED** – Provides a visual indication that a signal is being sensed by the input circuitry of the module. It also indicates the input signal strength by changing in intensity as the process changes from minimum to maximum. If the LED fails to illuminate, or fails to change in intensity as the process changes, this may indicate a problem with module power or signal input wiring.

**RED LoopTracker Output LED** – Provides a visual indication that the output signal is functioning. It becomes brighter as the input and the corresponding output change from minimum to maximum. For current outputs, the RED LED will only light if the output loop current path is complete. For either current or voltage outputs, failure to illuminate or a failure to change in intensity as the process changes may indicate a problem with the module power or signal output.

### CALIBRATION

Input and output ranges are pre-configured at the factory as specified on your order. Top-mounted, Zero and Span potentiometers can be used should fine-tuning be necessary. Custom ranges may require factory modification.

1. Apply power to the module and allow a minimum 20 minute warm up time.
2. Using an accurate calibration source, provide an input to the module equal to the minimum input required for the application.
3. Using an accurate measurement device for the output, adjust the Zero potentiometer for the exact minimum output desired. The Zero control should only be adjusted when the input signal is at its minimum. This will produce the corresponding minimum output signal. Example: for 4-20 mA output signal, the Zero control will provide adjustment for the 4 mA or low end of the signal.
4. Set the input at maximum, and then adjust the Span pot for the exact maximum output desired. The Span control should only be adjusted when the input signal is at its maximum. This will produce the corresponding maximum output signal. Example: for 4-20 mA output signal, the Span control will provide adjustment for the 20 mA or high end of the signal.
5. Repeat adjustments for maximum accuracy.

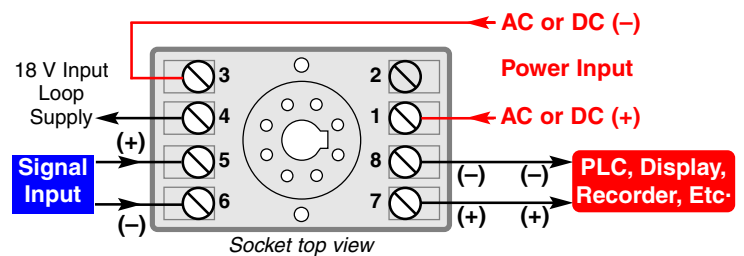

API 7010 G typical output wiring

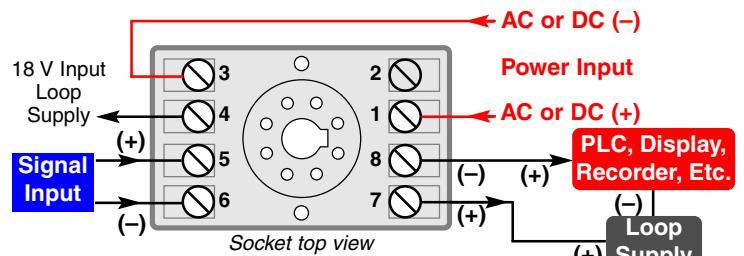

API 7010 G EXTSUP typical output wiring

API maintains a constant effort to upgrade and improve its products. Specifications are subject to change without notice. Consult factory for your specific requirements.

Frequency

**Using a Hall Effect Flow Sensor**

**PROBLEM**

An accurate flow measurement is required at low flow rates for a process controller. A local display is also desired.

**SOLUTION**

Hall effect sensors are recommended when the output frequency from a flow meter over any part of the application flow range is 15 Hz or less. This frequency typically occurs at approximately the 10 to 1 turndown point for flow meters.

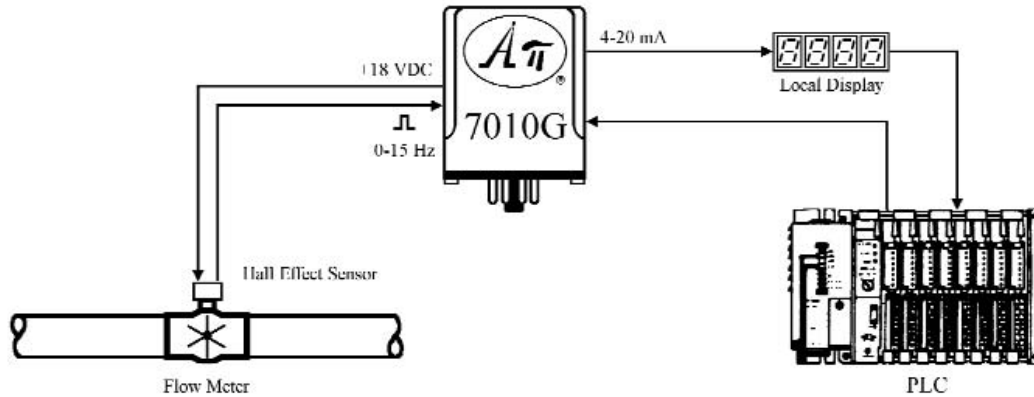

An **API 7010 G** Isolated Frequency to DC Transmitter module provides the DC power for the Hall Effect sensor from its built-in loop excitation supply and converts the 0-15 Hz flow signal into a 4-20 mA signal to drive the local display and the PLC. The 2000 VRMS isolation protects against unwanted ground loops and electrical noise.

**Monitoring Mixer Speed at a Remote Computer**

**PROBLEM**

The speed of a mixing machine must be monitored by a computer located 1500 feet away, across an electrically noisy area. The tachometer on the mixer produces 24 pulses per revolution at 15 V peak-to-peak and the mixer runs at speeds up to 50 RPM. The computer input accepts a frequency of 0-1000 Hz at 5 V peak-to-peak.

**SOLUTION**

Api signal conditioning is applied at the tachometer output and at the computer input to provide noise immunity and signal compatibility.

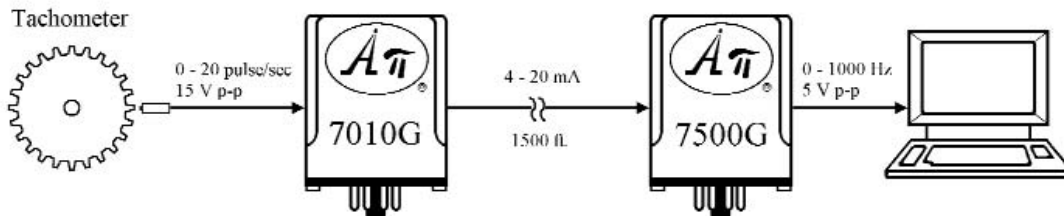

The tachometer output (24 pulse/rev x 50 rev/min x 1 min/60 sec = 20 pulse/sec) is converted to a 4-20 mADC signal by the **API 7010 G** Isolated Frequency to DC Transmitter module. At the computer, the 4-20 mADC signal is converted by the **API 7500 G** Field Selectable Isolated DC to Frequency Transmitter module to a frequency of 0-1000 Hz.

**FREE APPLICATION ASSISTANCE**  
 Call  Customer Service  
**800-794-5883**

**MOD-TRONIC**  
 INSTRUMENTS LIMITED

1 Delta Park Blvd #12  
 Brampton, ON L6T 5G1  
 905-457-6322 or 800-794-5883  
 www.mod-tronic.com

Frequency



## What is a Ground Loop?

In a process control loop, a ground loop circuit can develop when each device's ground is tied to a different earth potential thereby allowing current to flow between the grounds by way of the process loop (Figure 1).

Ground loops cause problems by adding or subtracting current or voltage from the process loop. This addition and/or subtraction causes the receiving device to be unable to differentiate between the wanted and unwanted signals and thus can't accurately reflect actual process signals.

The probability of multiple grounds and ground loops being established is especially high when new programmable logic controllers (PLCs) or distributed control systems (DCSs) are installed. With so many conditions within a facility referenced to ground, the likelihood of establishing more than one ground point is great. Thus, if an instrumentation system seems to be acting strangely or erratically, and the problem seems to point toward ground loops, the chore of eliminating all unintended ground connections becomes overwhelming.

Keep in mind that eliminating ground loops just isn't feasible for some instruments, such as thermocouples and some analyzers, because they require a ground to obtain accurate measurements. In addition, some instruments must be grounded to ensure personnel safety.

When ground loops can't be eliminated, the solution lies in the use of signal isolators. These devices break the galvanic path (DC continuity) between all grounds while allowing the analog signal to continue throughout the loop. An isolator also can eliminate the electrical noise of AC continuity (common mode voltage).

Signal isolators can use numerous techniques to achieve their function but the best signal isolators usually employ optical isolators (Figure 2). Regardless of the isolation method used, an isolator must provide input, output, and power isolation. If this three-way isolation is not provided, then an additional ground loop can develop between the isolator's power supply and the process input and/or output signal.

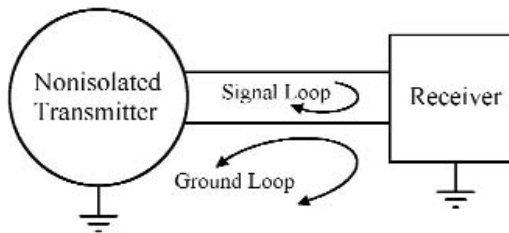

Figure 1. Ground loops may develop with non-isolated transmitters and receivers, resulting in inaccuracy and unreliability.

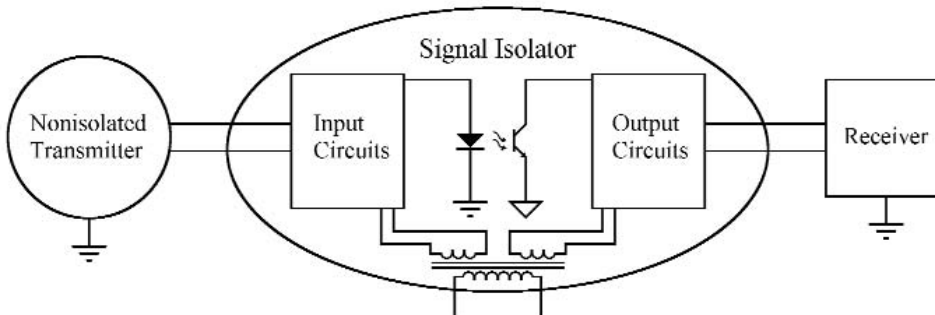
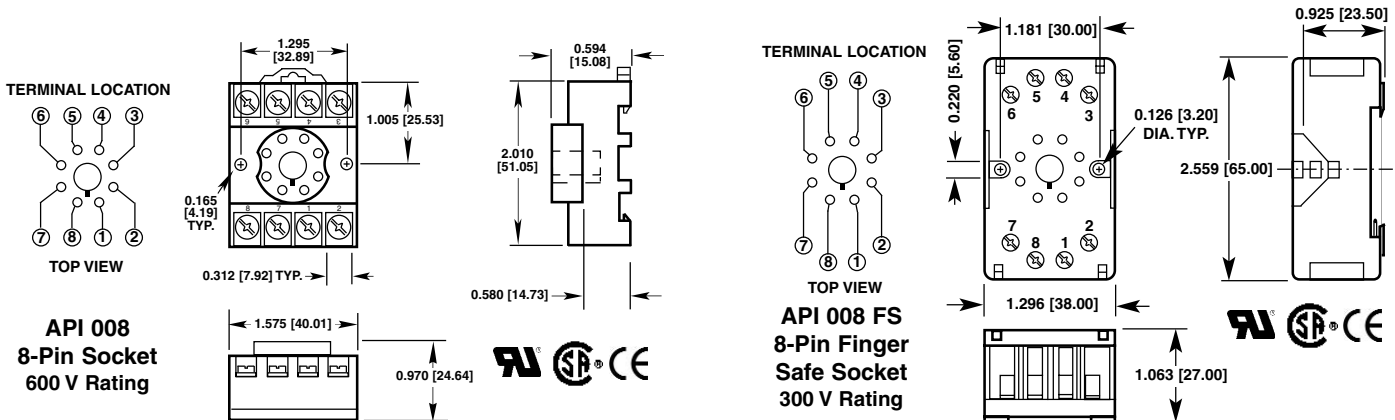

Figure 2. A signal isolator in the process loop blocks ground current to restore signal accuracy and reliability.

## API Sockets API 008 and API 008 FS



API maintains a constant effort to upgrade and improve its products. Specifications are subject to change without notice. Consult factory for your specific requirements.

# DC to Frequency Field Rangeable Isolator/Transmitter

**API 7500 G** 

**Input:** 0-50 mV to  $\pm 10$  VDC, 0-1 mA to 4-20 mADC  
**Output:** 0-100 Hz to 0-30 kHz MOSFET or TTL

- 24 Selectable Inputs & 30 Selectable Outputs
- Setup via Rotary Switches & Easy-to-use Tables
- 2000 V Full Isolation Input/Output/Power
- Adjustable Low Frequency Cutout
- Input and Output LoopTracker® LEDs
- Functional Test Pushbutton

## Applications

- Analog to Frequency for Totalizers & Counters
- Use With API 7010 G for Remote Monitoring

## Specifications

### Input Ranges

Voltage: 0-50 mVDC to  $\pm 10$  VDC  
 Current: 0-1 mADC to 0-20 mADC including 4-20 mA  
 Consult factory for other ranges  
 System voltages must not exceed socket voltage rating

### Input Impedance

Voltage: 1 M $\Omega$  minimum Current: 50  $\Omega$  typical

### Input Loop Power Supply

18 VDC nominal, unregulated, 25 mADC, max. ripple, less than 1.5 V<sub>p-p</sub>

### LoopTracker

Variable brightness LEDs indicate input/output loop level and status

### Output Ranges

	Minimum	Maximum	Range Increments
Low range:	0-100 Hz	0-1500 Hz	100 Hz
High range:	0-2 kHz	0-30 kHz	2 kHz

### Output Driver

Open drain MOSFET, 24 VDC maximum  
 $I_{sink}$  50 mA maximum  
 $V_{on}$  0.6 V maximum at 50 mA  $I_{sink}$   
 Optional 9 V<sub>p-p</sub> TTL output, specify **M02** option

### Output Linearity

Better than  $\pm 0.4\%$  of span

### Cutout Control

Disables output when input falls below preset level  
 Adjustable from 2% to 25% of range  
 Top accessible, multi-turn potentiometer.

### Output Zero and Span

Multiturn potentiometers to compensate for load and lead variations  
 $\pm 15\%$  of span adjustment range typical

### Functional Test Button

Sets output to test level when pressed  
 Potentiometer factory set to approximately 50% of span  
 Adjustable 2% to 100% of span

### Response Time

70 milliseconds typical  
 Consult factory for faster response times

### Isolation

2000 V<sub>RMS</sub> minimum  
 Full isolation: power to input, power to output, input to output

### Ambient Temperature Range

-10°C to +60°C operating

### Temperature Stability

Better than  $\pm 0.02\%$  of span per °C

### Power

Standard: 115 VAC  $\pm 10\%$ , 50/60 Hz, 2.5 W max.  
**A230** option: 230 VAC  $\pm 10\%$ , 50/60 Hz, 2.5 W max.  
**D** option: 9-30 VDC, 1.5 W typical

© Absolute Process Instruments, Inc. 11/04 LoopTracker—Reg TM Absolute Process Instruments, Inc.

**Wide Ranging I/O**  
**One Minute Setup!**

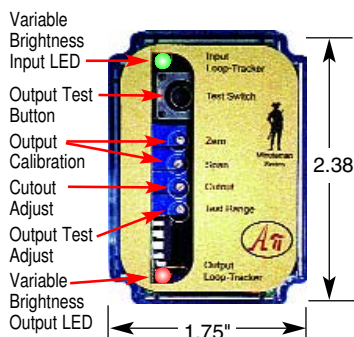

**Free Factory Input & Output Calibration!**

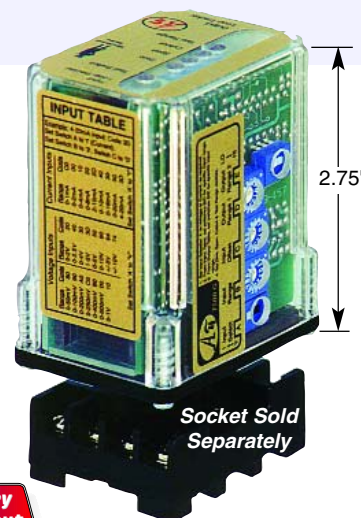

Frequency



## Description and Features

The **API 7500 G** accepts a DC voltage or current input and provides an optically isolated frequency output that is directly proportional to the input. Common applications include pulse counting or totalizing of DC process signals from devices such as flow transmitters, analog signal transmission over long distances, or analog inputs into PLCs. The full 3-way (input, output, power) isolation makes this module useful for ground loop elimination, common mode signal rejection or noise pickup reduction.

A low frequency cutout potentiometer can be adjusted to disable the output when the input falls below a pre-determined level. The **API 7500 G** can be field-configured via external rotary and slide switches. Common ranges are on the module label, however, virtually unlimited combinations are possible. Consult the factory for assistance with special ranges.

The **API 7500 G** has an open drain MOSFET (open collector) output which requires a user supplied external power supply and pull-up resistor allowing the module to be interfaced with a wide variety of devices. For a 9 V<sub>p-p</sub> powered output, order model **API 7500 G M02**.

API exclusive features include two **LoopTracker** LEDs and a **Functional Test Pushbutton**. The LoopTracker LEDs (Green for input, Red for output) vary in intensity with changes in the process input and output signals. Monitoring the state of these LEDs can provide a quick visual picture of your process loop at all times. The functional test pushbutton provides a fixed output (independent of the input) when held depressed. The test output level can be field-adjusted via a multiturn potentiometer.

Both the LoopTracker LEDs and functional test pushbutton greatly aid in saving time during initial startup and/or troubleshooting. The built-in 18 VDC unregulated loop excitation power supply can be used to power passive input devices.

## Models & Options

**API 7500 G** Field rangeable DC to frequency transmitter, isolated, with loop power supply, 115 VAC

*Options—Add to end of model number*

- A230** Powered by 230 VAC, 50/60 Hz
- D** Powered by 9-30 VDC
- M02** TTL 9 V<sub>p-p</sub> powered output instead of MOSFET output
- U** Conformal coating for moisture resistance

*Accessories—Order as separate line item*

- API 008** 8-pin socket
- API 008 FS** 8-pin finger-safe socket
- API TK36** DIN rail, 35 mm W x 39" L, aluminum

**MOD-TRONIC**  
 INSTRUMENTS LIMITED

1 Delta Park Blvd #12  
 Brampton, ON L6T 5G1  
 905-457-6322 or 800-794-5883  
 www.mod-tronic.com



## ELECTRICAL CONNECTIONS

**WARNING!** All wiring must be performed by qualified personnel only. This module requires an industry-standard 8-pin socket. Order API 008 or finger-safe API 008 FS socket separately.

**Power Input Terminals** – The white label on the side of the API module will indicate the power requirements. AC power is connected to terminals 1 and 3. For DC powered modules, polarity **MUST** be observed. Positive (+) is wired to terminal 1 and negative (-) is wired to terminal 3.

**Powered Signal Input** – Observe polarity when connecting the signal input. The positive signal (+) is wired to terminal 5 and negative (-) to terminal 6.

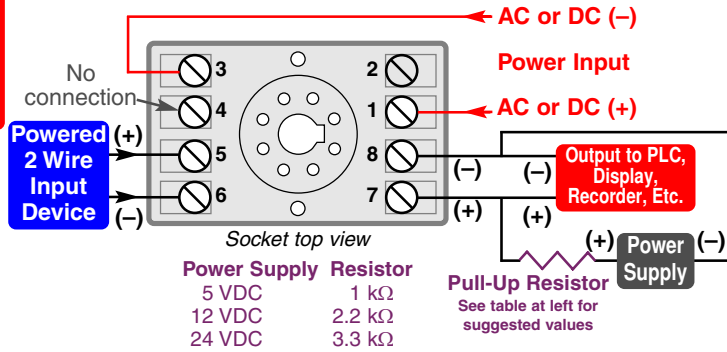

API 7500 G typical wiring with powered input and standard output

**Passive Signal Input Using the 18 V Supply** – Polarity must be observed when connecting the signal input. A passive input device can be powered by the 18 volt DC power supply at terminal 4 (+) and terminal 5 (-). This may save the expense of purchasing a separate power supply for the input device. A typical example is shown, however consult the manufacturer of your specific sensor to determine its compatibility and proper wiring.

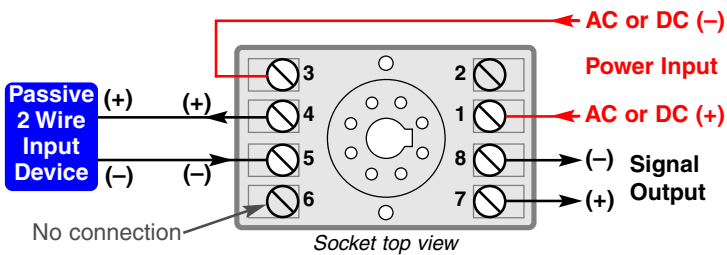

Using the built-in 18 VDC loop supply to power a passive input device

**Signal Output Terminals** – Polarity must be observed when connecting the signal output to the load. The positive connection (+) is connected to terminal 7 and the negative (-) is connected to terminal 8. The API 7500 G has an open drain MOSFET (open collector) output requiring a user-supplied external power supply and pull-up resistor.

**API 7500 G M02** – This model has a 9 V<sub>p-p</sub> TTL powered output and requires no external power supply or pull up resistor. Frequency output is a fixed amplitude of 9 VDC peak to peak with a maximum current drive capability of 10 mA.

## RANGE SELECTION

Three rotary switches and two slide switches located on the side of the module are used to select input and output ranges. Most popular ranges are listed on the module labels. See [www.api-usa.com](http://www.api-usa.com) or contact factory for special ranges.

- Set the **Input Select** slide switch to current (I) or voltage (V) depending on input type. The input selector switch determines the input impedance for the module, typically 50 Ω for current inputs and 1 MΩ or greater for voltage.
- From the table, find the rotary switch settings that match your input range and set **Input Range "B"** and **Input Offset "C"**.
- From the table, find your frequency range and set **Output Range 2 "E"** to HI or LO and set **Output Range 1 "D"** to match your frequency output range.

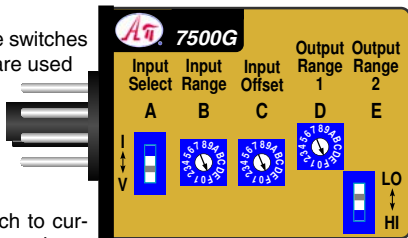

## CALIBRATION

Input and output ranges are pre-configured at the factory as specified on your order. Top-mounted, Zero and Span potentiometers can be used should fine-tuning be necessary. Custom ranges may require factory modification.

- Apply power to the module and allow a minimum 20 minute warm up time.
- Using an accurate frequency calibration source, provide an input to the module equal to the minimum input required for the application.
- Using an accurate measurement device for the output, adjust the Zero potentiometer for the exact minimum output desired. The Zero control should only be adjusted when the input signal is at its minimum. This will produce the corresponding minimum output signal of 0 Hz.
- Set the input at maximum, and then adjust the Span pot for the exact maximum output desired. The Span control should only be adjusted when the input signal is at its maximum. This will produce the corresponding maximum output signal.
- Repeat adjustments for maximum accuracy.

**Cutout Control** – This multi-turn potentiometer provides the user with a threshold adjustment. The Input signal must overcome this setting to produce an Output from the unit.

**Test Range Adjust** – Turn the multi-turn Test Range potentiometer while holding the Test button depressed until the desired output test level is reached.

## OPERATION

Depending on the rotary switch settings, the input is filtered, either amplified or attenuated as required, then passed through an optical isolation circuit to the output stage.

**Test Button** – The Test pushbutton may be set to provide the desired output when depressed. This will drive the device on the output side of the loop (a panel meter, chart recorder, etc.) with a known good signal that can be used as a system diagnostic aid during initial start-up or during troubleshooting. It can be adjusted to vary the output signal from 0 to 100% of the calibrated output range. When released, the output will return to normal.

**GREEN LoopTracker® Input LED** – Provides a visual indication that a signal is being sensed by the input circuitry of the module. It also indicates the input signal strength by changing in intensity as the process changes from minimum to maximum. If the LED fails to illuminate, or fails to change in intensity as the process changes, this may indicate a problem with module power or signal input wiring.

**RED LoopTracker Output LED** – Provides a visual indication that the output signal is functioning. It becomes brighter as the input and the corresponding output change from minimum to maximum. For current outputs, the RED LED will only light if the output loop current path is complete. For either current or voltage outputs, failure to illuminate or a failure to change in intensity as the process changes may indicate a problem with the module power or signal output wiring.

VOLTAGE Inputs Switch A To "V"		CURRENT Inputs Switch A To "I"		Frequency Outputs			
Range	B C	Range	B C	Range	D E	Range	D E
0-50 mV	8 0	0-1 mA	C 0	0-100 Hz	1 LO	0-2 kHz	1 HI
0-100 mV	9 0	0-2 mA	0 0	0-200 Hz	2 LO	0-4 kHz	2 HI
0-200 mV	A 0	0-4 mA	1 0	0-300 Hz	3 LO	0-6 kHz	3 HI
0-250 mV	C 0	0-8 mA	2 0	0-400 Hz	4 LO	0-8 kHz	4 HI
0-400 mV	B 0	2-10 mA	2 D	0-500 Hz	5 LO	0-10 kHz	5 HI
0-500 mV	0 0	0-10 mA	4 0	0-600 Hz	6 LO	0-12 kHz	6 HI
0-1 V	1 0	0-16 mA	3 0	0-700 Hz	7 LO	0-14 kHz	7 HI
0-2 V	2 0	0-20 mA	5 0	0-800 Hz	8 LO	0-16 kHz	8 HI
0-2.5 V	4 0	4-20 mA	3 D	0-900 Hz	9 LO	0-18 kHz	9 HI
0-4 V	3 0			0-1000 Hz	A LO	0-20 kHz	A HI
1-5 V	3 D			0-1100 Hz	B LO	0-22 kHz	B HI
0-5 V	5 0			0-1200 Hz	C LO	0-24 kHz	C HI
0-10 V	6 0			0-1300 Hz	D LO	0-26 kHz	D HI
±5 V	6 4			0-1400 Hz	E LO	0-28 kHz	E HI
±10 V	7 4			0-1500 Hz	F LO	0-30 kHz	F HI

API maintains a constant effort to upgrade and improve its products. Specifications are subject to change without notice. Consult factory for your specific requirements.

**Monitoring and Totalizing Flow**

**PROBLEM:**

Add a totalizer to a process flow monitoring system.

**SOLUTION:**

An **API 7500 G M02** Field Selectable Isolated DC to Frequency Transmitter module is inserted in the 4-20 mA loop between the turbine flow meter and the chart recorder.

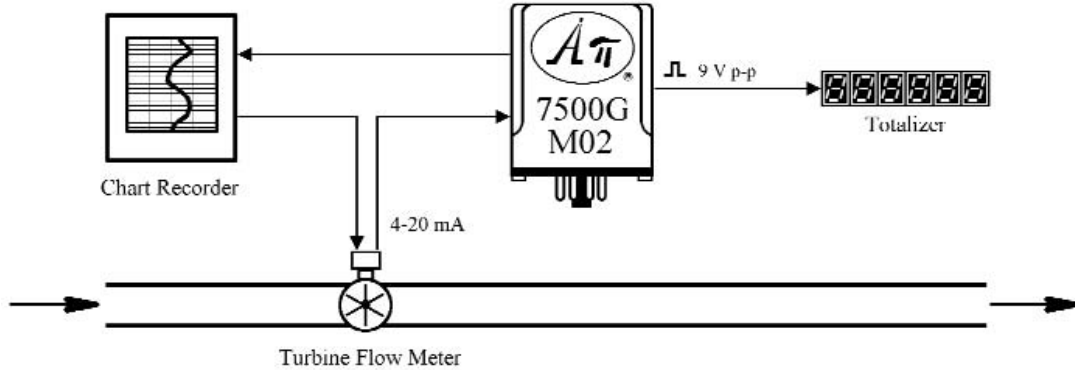

The **API 7500 G M02** provides the 9 V p-p square wave required by the totalizer system.

**Monitoring and Totalizing Flow Meter Output**

**PROBLEM**

The frequency output signal of a flow meter must be monitored by a DCS as well as a remotely located counter/totalizer. The counter/totalizer accepts a TTL frequency input.

**SOLUTION**

An **API 7580 G** Isolated Frequency to DC Transmitter module is connected to the frequency output of the flow meter. The **API 7580 G** has a built-in loop power supply to power the current loop.

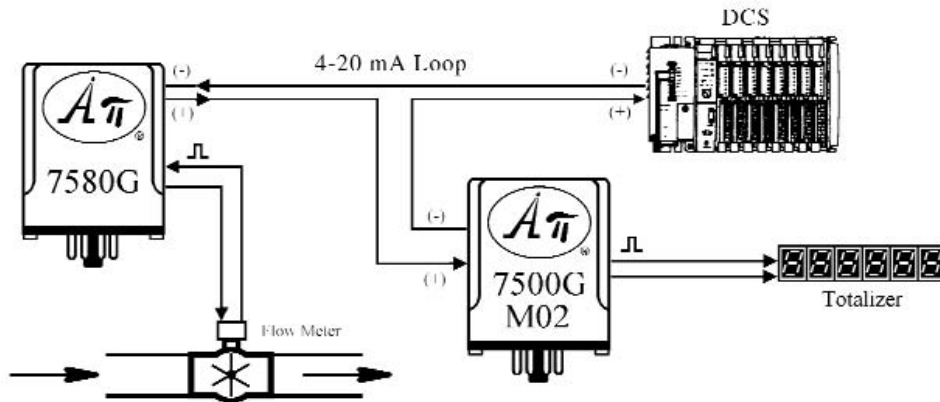

The **7580 G** converts the frequency to a 4-20 mA output which is sent to the DCS and an **API 7500G M02** mounted near the remote counter/totalizer. The **API 7500 G M02** converts the 4-20 mA signal to a TTL frequency signal for the counter/totalizer.

**FREE APPLICATION ASSISTANCE**  
 Call  Customer Service  
**800-794-5883**

**MOD-TRONIC**  
 INSTRUMENTS LIMITED  
 1 Delta Park Blvd #12  
 Brampton, ON L6T 5G1  
 905-457-6322 or 800-794-5883  
 www.mod-tronic.com

Frequency



## Monitoring Mixer Speed at a Remote Computer

### PROBLEM

The speed of a mixing machine must be monitored by a computer located 1500 feet away, across an electrically noisy area. The tachometer on the mixer produces 24 pulses per revolution at 15 V peak-to-peak and the mixer runs at speeds up to 50 RPM. The computer input accepts a frequency of 0-1000 Hz at 5 V peak-to-peak.

### SOLUTION

Api signal conditioning is applied at the tachometer output and at the computer input to provide noise immunity and signal compatibility.

Frequency

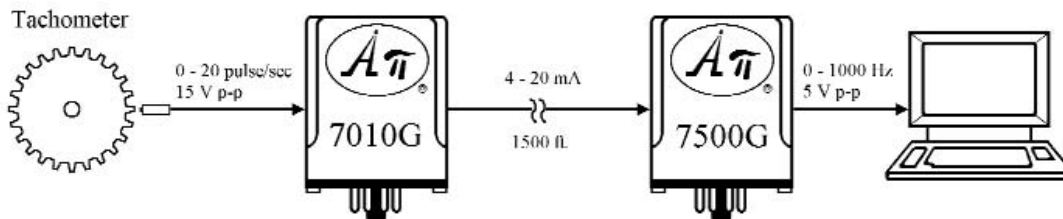

The tachometer output (24 pulse/rev x 50 rev/min x 1 min/60 sec = 20 pulse/sec) is converted to a 4-20 mADC signal by the **API 7010 G** Isolated Frequency to DC Transmitter module. At the computer, the 4-20 mADC signal is converted by the **API 7500 G** Field Selectable Isolated DC to Frequency Transmitter module to a frequency of 0-1000 Hz.

## Frequently Asked Questions

**Do you have a product that can provide an output signal of 5 KHz, 50% duty cycle, 20 mA max and 24 V<sub>p-p</sub> max with no input?**

Yes, the **API 7500G M03**.

**Can you provide a module that will generate an output frequency (square wave) that we can vary between 55 and 75 Hz with no input signal?**

Yes. Our **API 7500 G M03** with a modification to utilize the test circuit that is adjustable with the test range potentiometer. The test circuit is disabled internally and is always on. With the span pot set to the middle of the range, adjust the test range pot to give an output of 65 Hz which is the center point for 55-75 and serves to orient the window. Then, use the span pot to adjust the output frequency from 55 to 75 (the window is actually about 40 Hz). The zero pot and the cutout pot are disabled and have no effect.

**We have a 4-20 mA signal and want to convert it to a pulsed output of 0-270 pulses/minute so we can drive a counter. Can you do this?**

Yes. Convert the output to Hertz (cycles/second) so  $270 / 60 = 4.5$  Hz. Our **API 7500 G SS** has an output range of 0-5 Hz and the span pot can adjust down by 10 % to allow for 0-4.5 Hz. The counter, which will trip on either rising or falling edges, can be set up to count at the edge of each cycle (square wave).

**We have an application which requires a signal conversion of 1/2 Hz to 6 Hz input to a DC output. Do you have a signal conditioner to do this?**

No. The minimum input frequency range that we offer is 0 to 15 Hz.

## API Sockets API 008 and API 008 FS

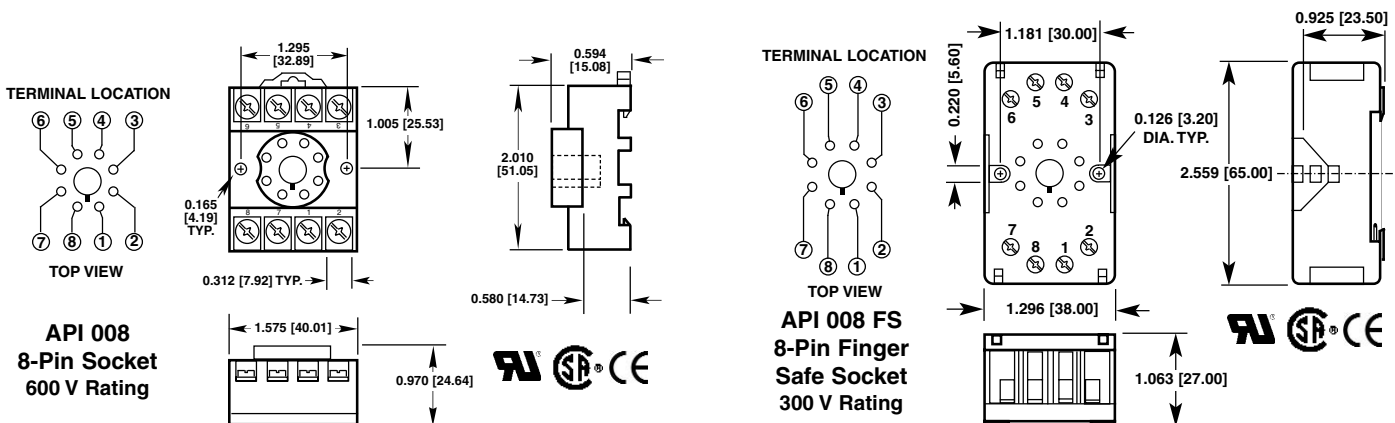

API maintains a constant effort to upgrade and improve its products. Specifications are subject to change without notice. Consult factory for your specific requirements.

# Low DC to Frequency Isolator & Field Rangeable Transmitter

# API 7500 G SS



**Input:** 0-50 mV to  $\pm 10$  VDC, 0-1 mA to 4-20 mADC  
**Output:** 0-1 Hz to 0-300 Hz MOSFET or TTL

- 24 Selectable Inputs & 30 Selectable Outputs
- Setup via Rotary Switches & Easy-to-use Tables
- 2000 V Full Isolation Input/Output/Power
- Adjustable Low Frequency Cutout
- Input and Output LoopTracker® LEDs
- Functional Test Pushbutton

## Applications

- Analog to Frequency for Totalizers & Counters
- Use With API 7010 G for Remote Monitoring

## Specifications

### Input Ranges

Voltage: 0-50 mVDC to  $\pm 10$  VDC  
 Current: 0-1 mADC to 0-20 mADC including 4-20 mA  
 Consult factory for other ranges  
 System voltages must not exceed socket voltage rating

### Input Impedance

Voltage: 1 M $\Omega$  minimum Current: 50  $\Omega$  typical

### Input Loop Power Supply

18 VDC nominal, unregulated, 25 mADC, max. ripple, less than 1.5 V<sub>p-p</sub>

### LoopTracker

Variable brightness LEDs indicate input/output loop level and status

### Output Ranges

	Minimum	Maximum	Range Increments
Low range:	0-1 Hz	0-15 Hz	1 Hz
High range:	0-20 Hz	0-300 Hz	20 Hz

### Output Driver

Open drain MOSFET, 24 VDC maximum  
 I<sub>sink</sub> 50 mA maximum  
 V<sub>on</sub> 0.6 V maximum at 50 mA I<sub>sink</sub>  
 Optional 9 V<sub>p-p</sub> TTL output, specify M02 option

### Output Linearity

Better than  $\pm 0.4\%$  of span

### Cutout Control

Disables output when input falls below preset level  
 Adjustable from 2% to 25% of range  
 Top accessible, multi-turn potentiometer.

### Output Zero and Span

Multiturn potentiometers to compensate for load and lead variations  
 $\pm 15\%$  of span adjustment range typical

### Functional Test Button

Sets output to test level when pressed  
 Potentiometer factory set to approximately 50% of span  
 Adjustable 2% to 100% of span

### Response Time

70 milliseconds typical  
 Consult factory for faster response times

### Isolation

2000 V<sub>RMS</sub> minimum  
 Full isolation: power to input, power to output, input to output

### Ambient Temperature Range

-10°C to +60°C operating

### Temperature Stability

Better than  $\pm 0.02\%$  of span per °C

### Power

Standard: 115 VAC  $\pm 10\%$ , 50/60 Hz, 2.5 W max.  
 A230 option: 230 VAC  $\pm 10\%$ , 50/60 Hz, 2.5 W max.  
 D option: 9-30 VDC, 1.5 W typical

© Absolute Process Instruments, Inc. 11/04 LoopTracker—Reg TM Absolute Process Instruments, Inc.



**Wide Ranging I/O**  
**One Minute Setup!**

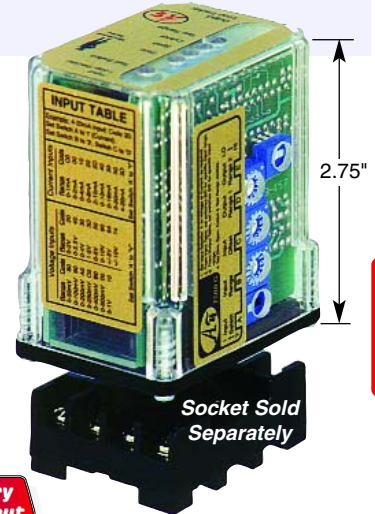
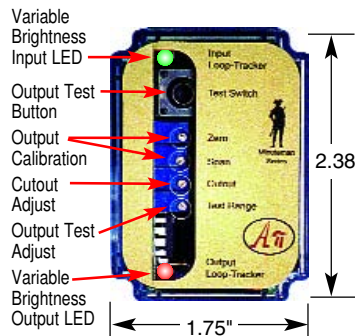

Frequency



**Free Factory Input & Output Calibration!**



## Description and Features

The **API 7500 G SS** accepts a DC voltage or current input and provides an optically isolated frequency output that is directly proportional to the input. Common applications include pulse counting or totalizing of DC process signals from devices such as flow transmitters, analog signal transmission over long distances, or analog inputs into PLCs. The full 3-way (input, output, power) isolation makes this module useful for ground loop elimination, common mode signal rejection or noise pickup reduction.

A low frequency cutout potentiometer can be adjusted to disable the output when the input falls below a pre-determined level. The **API 7500 G SS** can be field-configured via external rotary and slide switches. Common ranges are on the module label, however, virtually unlimited combinations are possible. Consult the factory for assistance with special ranges.

The **API 7500 G SS** has an open drain MOSFET (open collector) output which requires a user supplied external power supply and pull-up resistor allowing the module to be interfaced with a wide variety of devices. For a 9 V<sub>p-p</sub> powered output, order model **API 7500 G SS M02**.

API exclusive features include two **LoopTracker** LEDs and a **Functional Test Pushbutton**. The LoopTracker LEDs (Green for input, Red for output) vary in intensity with changes in the process input and output signals. Monitoring the state of these LEDs can provide a quick visual picture of your process loop at all times. The functional test pushbutton provides a fixed output (independent of the input) when held depressed. The test output level can be field-adjusted via a multiturn potentiometer.

Both the LoopTracker LEDs and functional test pushbutton greatly aid in saving time during initial startup and/or troubleshooting. The built-in 18 VDC unregulated loop excitation power supply can be used to power passive input devices.

## Models & Options

**API 7500 G SS** Field rangeable DC to low frequency transmitter, isolated, with loop power supply, 115 VAC

Options—Add to end of model number

<b>A230</b>	Powered by 230 VAC, 50/60 Hz
<b>D</b>	Powered by 9-30 VDC
<b>M02</b>	TTL 9 V <sub>p-p</sub> powered output instead of MOSFET output
<b>U</b>	Conformal coating for moisture resistance

Accessories—Order as separate line item

<b>API 008</b>	8-pin socket
<b>API 008 FS</b>	8-pin finger-safe socket
<b>API TK36</b>	DIN rail, 35 mm W x 39" L, aluminum



1 Delta Park Blvd #12  
 Brampton, ON L6T 5G1  
 905-457-6322 or 800-794-5883  
 www.mod-tronic.com



## ELECTRICAL CONNECTIONS

**WARNING!** All wiring must be performed by qualified personnel only. This module requires an industry-standard 8-pin socket. Order API 008 or finger-safe API 008 FS socket separately.

**Power Input Terminals** – The white label on the side of the API module will indicate the power requirements. AC power is connected to terminals 1 and 3. For DC powered modules, polarity **MUST** be observed. Positive (+) is wired to terminal 1 and negative (-) is wired to terminal 3.

**Powered Signal Input** – Observe polarity when connecting the signal input. The positive signal (+) is wired to terminal 5 and negative (-) to terminal 6.

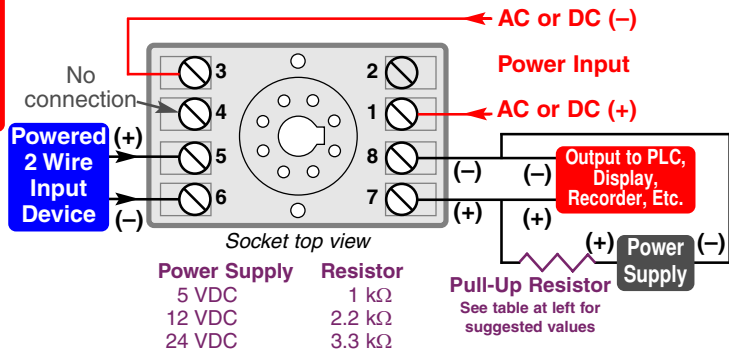

API 7500 G SS typical wiring with powered input and standard output

**Passive Signal Input Using the 18 V Supply** – Polarity must be observed when connecting the signal input. A passive input device can be powered by the 18 volt DC power supply at terminal 4 (+) and terminal 5 (-). This may save the expense of purchasing a separate power supply for the input device. A typical example is shown, however consult the manufacturer of your specific sensor to determine its compatibility and proper wiring.

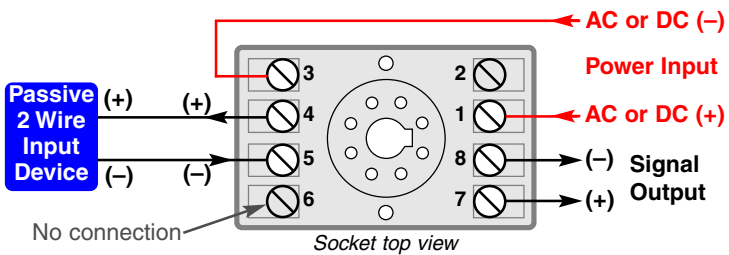

Using the built-in 18 VDC loop supply to power a passive input device

**Signal Output Terminals** – Polarity must be observed when connecting the signal output to the load. The positive connection (+) is connected to terminal 7 and the negative (-) is connected to terminal 8. The API 7500 G SS has an open drain MOSFET (open collector) output requiring a user-supplied external power supply and pull-up resistor.

**API 7500 G SS M02** – This model has a 9 V<sub>p-p</sub> TTL powered output and requires no external power supply or pull up resistor. Frequency output is a fixed amplitude of 9 VDC peak to peak with a maximum current drive capability of 10 mA.

## RANGE SELECTION

Three rotary switches and two slide switches located on the side of the module are used to select input and output ranges. Most popular ranges are listed on the module labels. See [www.api-usa.com](http://www.api-usa.com) or contact factory for special ranges.

- Set the **Input Select** slide switch to current (I) or voltage (V) depending on input type. The input selector switch determines the input impedance for the module, typically 50 Ω for current inputs and 1 MΩ or greater for voltage.
- From the table, find the rotary switch settings that match your input range and set **Input Range "B"** and **Input Offset "C"**.
- From the table, find your frequency range and set **Output Range 2 "E"** to HI or LO and set **Output Range 1 "D"** to match your frequency output range.

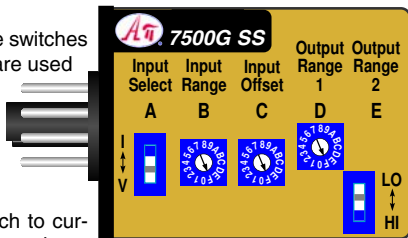

## CALIBRATION

Input and output ranges are pre-configured at the factory as specified on your order. Top-mounted, Zero and Span potentiometers can be used should fine-tuning be necessary. Custom ranges may require factory modification.

- Apply power to the module and allow a minimum 20 minute warm up time.
- Using an accurate frequency calibration source, provide an input to the module equal to the minimum input required for the application.
- Using an accurate measurement device for the output, adjust the Zero potentiometer for the exact minimum output desired. The Zero control should only be adjusted when the input signal is at its minimum. This will produce the corresponding minimum output signal of 0 Hz.
- Set the input at maximum, and then adjust the Span pot for the exact maximum output desired. The Span control should only be adjusted when the input signal is at its maximum. This will produce the corresponding maximum output signal.
- Repeat adjustments for maximum accuracy.

**Cutoff Control** – This multi-turn potentiometer provides the user with a threshold adjustment. The Input signal must overcome this setting to produce an Output from the unit.

**Test Range Adjust** – Turn the multi-turn Test Range potentiometer while holding the Test button depressed until the desired output test level is reached.

## OPERATION

Depending on the rotary switch settings, the input is filtered, either amplified or attenuated as required, then passed through an optical isolation circuit to the output stage.

**Test Button** – The Test pushbutton may be set to provide the desired output when depressed. This will drive the device on the output side of the loop (a panel meter, chart recorder, etc.) with a known good signal that can be used as a system diagnostic aid during initial start-up or during troubleshooting. It can be adjusted to vary the output signal from 0 to 100% of the calibrated output range. When released, the output will return to normal.

**GREEN LoopTracker® Input LED** – Provides a visual indication that a signal is being sensed by the input circuitry of the module. It also indicates the input signal strength by changing in intensity as the process changes from minimum to maximum. If the LED fails to illuminate, or fails to change in intensity as the process changes, this may indicate a problem with module power or signal input wiring.

**RED LoopTracker Output LED** – Provides a visual indication that the output signal is functioning. It becomes brighter as the input and the corresponding output change from minimum to maximum. For current outputs, the RED LED will only light if the output loop current path is complete. For either current or voltage outputs, failure to illuminate or a failure to change in intensity as the process changes may indicate a problem with the module power or signal output wiring.

VOLTAGE Inputs Switch A To "V"		CURRENT Inputs Switch A To "I"		Frequency Outputs			
Range	B C	Range	B C	Range	D E	Range	D E
0-50 mV	8 0	0-1 mA	C 0	0-1 Hz	1 LO	0-20 Hz	1 HI
0-100 mV	9 0	0-2 mA	0 0	0-2 Hz	2 LO	0-40 Hz	2 HI
0-200 mV	A 0	0-4 mA	1 0	0-3 Hz	3 LO	0-60 Hz	3 HI
0-250 mV	C 0	0-8 mA	2 0	0-4 Hz	4 LO	0-80 Hz	4 HI
0-400 mV	B 0	2-10 mA	2 D	0-5 Hz	5 LO	0-100 Hz	5 HI
0-500 mV	0 0	0-10 mA	4 0	0-6 Hz	6 LO	0-120 Hz	6 HI
0-1 V	1 0	0-16 mA	3 0	0-7 Hz	7 LO	0-140 Hz	7 HI
0-2 V	2 0	0-20 mA	5 0	0-8 Hz	8 LO	0-160 Hz	8 HI
0-2.5 V	4 0	4-20 mA	3 D	0-9 Hz	9 LO	0-180 Hz	9 HI
0-4 V	3 0			0-10 Hz	A LO	0-200 Hz	A HI
1-5 V	3 D			0-11 Hz	B LO	0-220 Hz	B HI
0-5 V	5 0			0-12 Hz	C LO	0-240 Hz	C HI
0-10 V	6 0			0-13 Hz	D LO	0-260 Hz	D HI
±5 V	6 4			0-14 Hz	E LO	0-280 Hz	E HI
±10 V	7 4			0-15 Hz	F LO	0-300 Hz	F HI

API maintains a constant effort to upgrade and improve its products. Specifications are subject to change without notice. Consult factory for your specific requirements.

# Frequency to DC Isolator & Field Rangeable Transmitter

# API 7580 G

**Input:** 0-100 Hz to 0-30 kHz  
**Output:** 0-50 mV to  $\pm 10$  VDC, 0-2 mA to 4-20 mADC

- 30 Selectable Inputs & 16 Selectable Outputs
- Setup via Rotary Switches & Easy-to-Use Tables
- 2000 V Full Isolation Input/Output/Power
- Adjustable Input Sensitivity (Hysteresis)
- Input and Output Looptracker® LEDs
- Functional Test Pushbutton

## Applications

- Monitor and Control Motor or Line Speed
- Convert a Square Wave Output to 4-20 mA

## Specifications

### Input Ranges

	Minimum	Maximum	Range Increments
Low range:	0-100 Hz	0-1500 Hz	100 Hz
High range:	0-2 kHz	0-30 kHz	2 kHz

### Input Impedance

10 k $\Omega$  nominal (maximum sensitivity)  
 100 k $\Omega$  nominal (minimum sensitivity)

### Input Sensitivity/Hysteresis

Single turn potentiometer for sensitivity adjustment  
 Maximum sensitivity:  $\pm 25$  mV typical  
 Minimum sensitivity:  $\pm 2.5$  V typical

### Input Amplitude Range

100 mV to 150 V<sub>RMS</sub> System voltages must not exceed socket voltage rating

### Input Waveform

Sine wave  Sawtooth  Square wave   
 Most other waveforms with greater than 100 mV amplitude change

### Input Loop Power Supply

18 VDC nominal, unregulated, 25 mADC, max. ripple, less than 1.5 V<sub>p-p</sub>

### LoopTracker

Variable brightness LEDs indicate input/output loop level and status

### Output Ranges

	Minimum	Maximum	Load Factor
Voltage:	0-1 VDC	0-10 VDC	
Bipolar Voltage:	$\pm 1$ VDC	$\pm 10$ VDC	
Current (20 V compliance):	0-2 mADC	0-20 mADC	1000 $\Omega$ at 20 mA

Consult factory for other ranges

### Output Zero and Span

Multiturn potentiometers to compensate for load and lead variations  
 Zero:  $\pm 15\%$  of span adjustment range typical  
 Span:  $\pm 10\%$  of span adjustment range typical

### Functional Test Button

Sets output to test level when pressed. Adjustable 0-100% of span.  
 Potentiometer factory set to approx. 50% of span

### Response Time

Low ranges: 600 millisecond. typical      High ranges: 110 millisecond. typical

### Accuracy

Better than  $\pm 0.2\%$  of span including hysteresis, linearity and adjustment resolution. Better than  $\pm 0.8\%$  repeatability

### Isolation

2000 V<sub>RMS</sub> min. Full isolation: power to input, power to output, input to output

### Ambient Temperature Range and Stability

-10°C to +60°C operating ambient  
 Better than  $\pm 0.02\%$  of span per °C stability

### Power

Standard: 115 VAC  $\pm 10\%$ , 50/60 Hz, 2.5 W max.  
**A230** option: 230 VAC  $\pm 10\%$ , 50/60 Hz, 2.5 W max.  
**D** option: 9-30 VDC, 2.5 W typical



**Wide Ranging I/O**  
**One Minute Setup!**

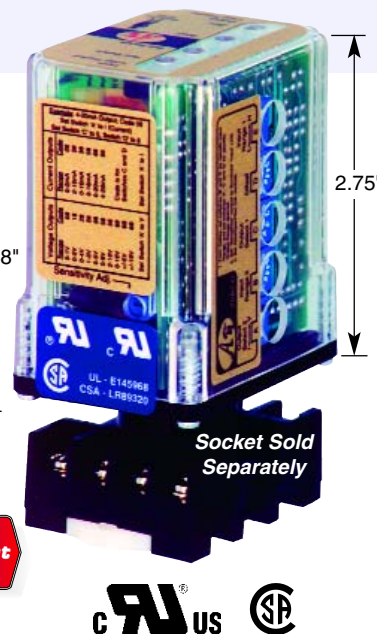
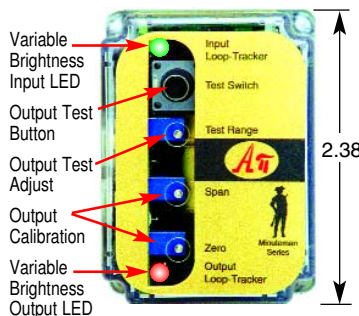

**Free Factory Input & Output Calibration!**



## Description and Features

The **API 7580 G** accepts a frequency Input and provides an optically isolated DC voltage or current analog output that is linearly proportional to the input.

Common applications include frequency to DC conversions from frequency output type devices such as rotary encoders, magnetic pick-ups, variable speed drives and flow meters. For PLCs that do not have analog outputs, often the pulse rate of a discreet output can be programmed to vary. By connecting the **API 7580 G** to this output, a proportional analog signal can be generated.

The full 3-way (input, output, power) isolation makes this module useful for ground loop elimination, common mode signal rejection or noise pickup reduction.

The **API 7580 G** input and output can be field-configured via external rotary and slide switches. The more common ranges (30 input & 16 output) can be selected from the table on the module. Many additional combinations are possible. Consult the factory for assistance with special ranges.

API exclusive features include two **LoopTracker** LEDs and a **Functional Test Pushbutton**. The LoopTracker LEDs (Green for input, Red for output) vary in intensity with changes in the process input and output signals. Monitoring the state of these LEDs can provide a quick visual picture of your process loop at all times. The functional test pushbutton provides a fixed output (independent of the input) when held depressed. The test output level can be field-adjusted via a multiturn potentiometer.

Both the LoopTracker LEDs and functional test pushbutton greatly aid in saving time during initial startup and/or troubleshooting. The built-in 18 VDC unregulated loop excitation power supply can be used to power passive input devices.

## Models & Options

**API 7580 G** Field rangeable frequency to DC transmitter, isolated, with loop power supply, 115 VAC

- Options—Add to end of model number**  
**A230** Powered by 230 VAC, 50/60 Hz  
**D** Powered by 9-30 VDC  
**U** Conformal coating for moisture resistance

**Accessories—Order as separate line item**

- API 008** 8-pin socket  
**API 008 FS** 8-pin finger-safe socket  
**API TK36** DIN rail, 35 mm W x 39" L, aluminum



1 Delta Park Blvd #12  
 Brampton, ON L6T 5G1  
 905-457-6322 or 800-794-5883  
 www.mod-tronic.com



## ELECTRICAL CONNECTIONS

**WARNING!** All wiring must be performed by qualified personnel only. This module requires an industry-standard 8-pin socket. Order API 008 or finger-safe API 008 FS socket separately.

**Power Input Terminals** – The white label on the side of the API module will indicate the power requirements. AC power is connected to terminals 1 and 3. For DC powered modules, polarity **MUST** be observed. Positive (+) is wired to terminal 1 and negative (-) is wired to terminal 3.

**Powered Signal Input** – Observe polarity when connecting the signal input. The positive signal (+) is wired to terminal 5 and negative (-) to terminal 6.

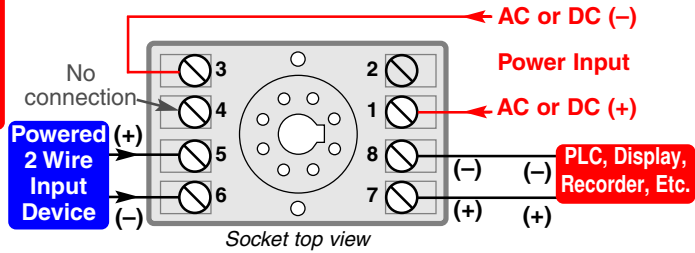

API 7580 G typical wiring with powered input and standard output

**Passive Signal Input Using the 18 V Supply** – Polarity must be observed when connecting the signal input. A passive input device can be powered by the 18 volt DC power supply at terminal 4 (+) and terminal 5 (-). This may save the expense of purchasing a separate power supply for the input device. A typical example is shown, however consult the manufacturer of your specific sensor to determine its compatibility and proper wiring.

**Signal Output Terminals** – Polarity must be observed when connecting the signal output to the load. The positive connection (+) is connected to terminal 7 and the negative (-) is connected to terminal 8. The API 7580 G provides a powered output to drive the output loop.

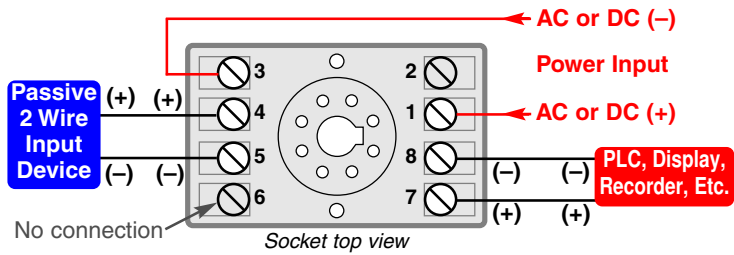

Using the built-in 18 VDC loop supply to power a passive input device

## RANGE SELECTION

Three rotary switches and two slide switches located on the side of the module are used to select input and output ranges. Most popular ranges are listed on the module labels and the table at right. See [www.api-usa.com](http://www.api-usa.com) or contact factory for special ranges.

1. Set the **Output Select 2** slide switch "A" to current (I) or voltage (V) depending on output type.
2. Set the **Input Range 1** slide switch "E" to either L or H depending on input frequency range.

For frequencies from 0-100 Hz thru 0-1500 Hz, switch "E" is placed in the L position.

For frequencies from 0-2000 Hz thru 0-30 kHz, switch "E" is placed in the H position.

3. Find your input frequency range and set **Input Range 2** rotary switch "B".
4. Find your output range and set **Output Range "C"** and **Output Offset "D"**.
5. The Zero, Span, Sensitivity, and Test Range potentiometers can now be adjusted.

Depending on the rotary switch settings, the input is filtered, either amplified or attenuated as required, then passed through an optical isolation circuit to the output stage.

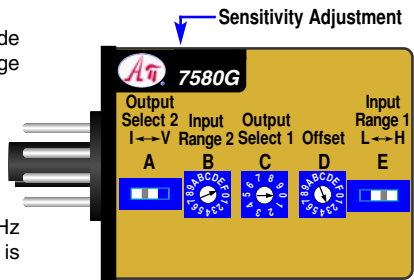

API maintains a constant effort to upgrade and improve its products. Specifications are subject to change without notice. Consult factory for your specific requirements.

## CALIBRATION

**Input & Output Ranges** – Range are pre-set at the factory as specified on your order. Top-mounted, Zero and Span potentiometers can be used should fine-tuning be necessary. Custom ranges may require factory modification.

1. Apply power to the module and allow a minimum 20 minute warm up time.
2. Using an accurate frequency calibration source, provide an input to the module equal to the minimum input required for the application.
3. Using an accurate measurement device for the output, adjust the Zero potentiometer for the exact minimum output desired. The Zero control should only be adjusted when the input signal is at its minimum. This will produce the corresponding minimum output signal of 0 Hz.
4. Set the input at maximum, and then adjust the Span pot for the exact maximum output desired. The Span control should only be adjusted when the input signal is at its maximum. This will produce the corresponding maximum output signal.
5. Repeat adjustments for maximum accuracy.

**Sensitivity Adjust** – This single turn potentiometer located on the side of the module provides an adjustable threshold level that the incoming signal must overcome before an output can be produced. This is used to limit noise and minimize false input signals that may cause erroneous readings.

When fully clockwise (maximum sensitivity), the input threshold is typically  $\pm 25$  mV. In the fully counterclockwise position (minimum sensitivity), the input threshold is typically  $\pm 2.5$  Volts.

**Test Range Adjust** – Turn the multi-turn Test Range potentiometer while holding the Test button depressed until the desired output test level is reached. It can be adjusted to vary the output signal from 0 to 100% of the output range.

## OPERATION

The frequency input to the API 7580 G is capacitively coupled (to remove any DC component at the input) to a comparator whose threshold is determined by the setting of the sensitivity control. The output from the comparator passes through an opto-coupler to the output stage.

**Test Button** – Drives a device on the output side of the loop (a panel meter, chart recorder, etc.) with a known good signal that can be used as a system diagnostic aid during initial start-up or during troubleshooting. When released, the output will return to normal.

**GREEN LoopTracker® Input LED** – Provides a visual indication that a signal is being sensed by the input circuitry of the module. The LED illuminates when the input is sufficiently large to trigger the input comparator depending on the input sensitivity adjustment. It also indicates the input signal range by changing in intensity as the frequency changes from minimum to maximum. If the LED fails to illuminate, or change in intensity as the frequency changes, it may indicate a problem with module power, or signal input wiring.

**RED LoopTracker Output LED** – Provides a visual indication that the output signal is functioning. It becomes brighter as the input and the corresponding output change from minimum to maximum. For current outputs, the RED LED will only light if the output loop current path is complete. For either current or voltage outputs, failure to illuminate or a failure to change in intensity as the process changes may indicate a problem with the module power or signal output wiring.

Frequency Inputs				VOLTAGE Outputs		CURRENT Outputs	
50 VDC or 150 VAC Maximum				Switch A To "V"		Switch A To "I"	
Range	B	E	Range	B	E	Range	C D
0-100 Hz	1	LO	0-2 kHz	1	HI	0-1 V	0 8
0-200 Hz	2	LO	0-4 kHz	2	HI	0-2 V	1 8
0-300 Hz	3	LO	0-6 kHz	3	HI	0-4 V	2 8
0-400 Hz	4	LO	0-8 kHz	4	HI	1-5 V	2 6
0-500 Hz	5	LO	0-10 kHz	5	HI	0-5 V	3 8
0-600 Hz	6	LO	0-12 kHz	6	HI	0-8 V	5 8
0-700 Hz	7	LO	0-14 kHz	7	HI	2-10 V	5 6
0-800 Hz	8	LO	0-16 kHz	8	HI	0-10 V	6 8
0-900 Hz	9	LO	0-18 kHz	9	HI	$\pm 5$ V	6 B
0-1000 Hz	A	LO	0-20 kHz	A	HI	$\pm 10$ V	8 B
0-1100 Hz	B	LO	0-22 kHz	B	HI		
0-1200 Hz	C	LO	0-24 kHz	C	HI		
0-1300 Hz	D	LO	0-26 kHz	D	HI		
0-1400 Hz	E	LO	0-28 kHz	E	HI		
0-1500 Hz	F	LO	0-30 kHz	F	HI		

### Auto-Ranging Flow Meter

**PROBLEM**

A flow in a process must be accurately measured throughout a wide range. The flow rate is used by a PLC to control the process. Two flow meters are utilized, one very accurate at low flow and one very accurate at high flow. A means for automatic selection of the appropriate flow meter is required.

**SOLUTION**

An **API 7580 G** Field Selectable Isolated Frequency to DC Transmitter module is used with each flow meter to convert the frequency output to a 0-10 VDC signal proportional to flow. An **API 1080 DIN** DC Input, Wide Ranging, Field Selectable Single Alarm Trip module monitors the flow rate and transfers the PLC analog input to the flow meter appropriate for that range.

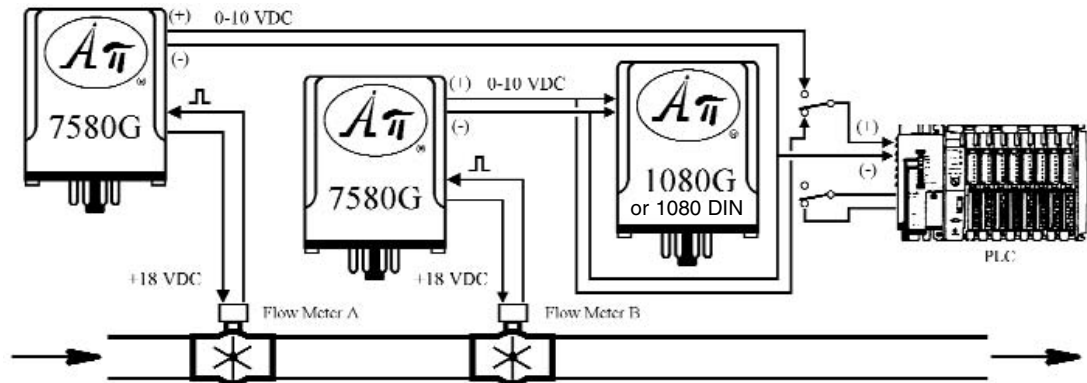

The second set of relay contacts of the **API 1080 DIN** provides a PLC binary input with a closure to indicate which flow meter is selected.

### Controlling and Recording Water Flow

**PROBLEM**

A process requires a controlled water flow which must also be recorded.

**SOLUTION**

A linear flow meter and a control valve are installed in the water line. Power for the flow meter is provided by the +18 VDC loop excitation supply available as standard on an **API 7580 G** Field Selectable Isolated Frequency to DC Transmitter module. The **API 7580 G** converts the frequency output of the flow meter to a 4-20 mA signal which is used to control and monitor the flow to the process.

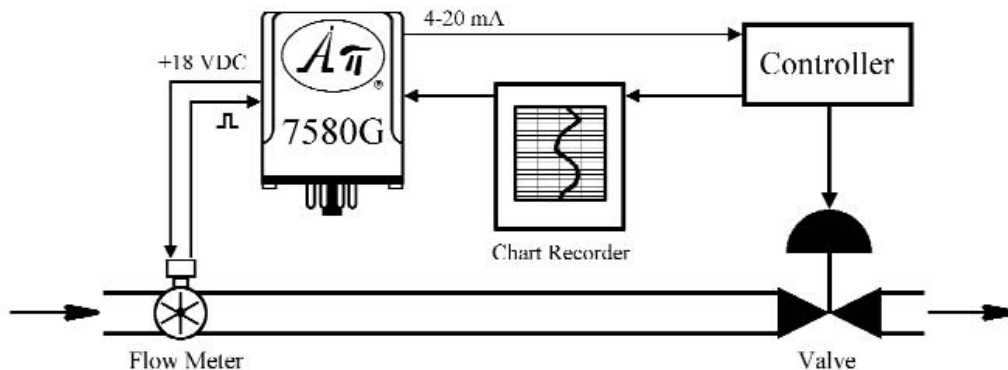

The **API 7580 G** features 30 selectable input ranges from 0-100 Hz to 0-30 KHz, and 16 selectable output ranges. In addition, the optical isolation protects against unwanted ground loops and electrical noise.



**FREE APPLICATION ASSISTANCE**  
 Call  Customer Service  
**800-794-5883**

**MOD-TRONIC**  
 INSTRUMENTS LIMITED

1 Delta Park Blvd #12  
 Brampton, ON L6T 5G1  
 905-457-6322 or 800-794-5883  
 www.mod-tronic.com

Frequency



## Monitoring and Totalizing Flow Meter Output

### PROBLEM

The frequency output signal of a flow meter must be monitored by a DCS as well as a remotely located counter/totalizer. The counter/totalizer accepts a TTL frequency input.

### SOLUTION

An API 7580 G Isolated Frequency to DC Transmitter module is connected to the frequency output of the flow meter. The API 7580 G has a built-in loop power supply to power the current loop.

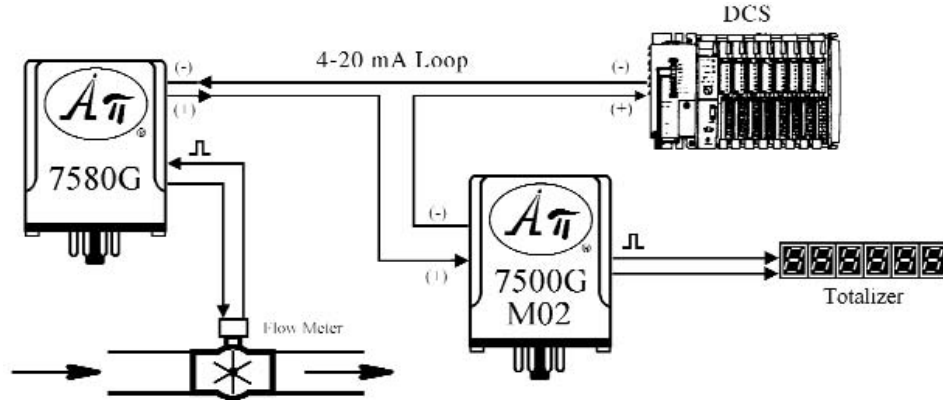

The 7580 G converts the frequency to a 4-20 mA output which is sent to the DCS and an API 7500G M02 mounted near the remote counter/totalizer. The API 7500 G M02 converts the 4-20 mA signal to a TTL frequency signal for the counter/totalizer.

## HVAC Variable Air Volume Control

### PROBLEM

The constant volume heating, ventilating and air conditioning (HVAC) system for a wet chemistry laboratory is being converted to variable air volume (VAV) to save energy. The amount of air exhausted by four fume hoods in the lab will vary depending upon their sash positions. A room controller must monitor the room temperature, the quantity of air exhausted and the quantity of air supplied, and operate supply air, auxiliary supply air, and general exhaust air valves to maintain room temperature, room pressure and a minimum number of air changes per hour for comfort and safety. The room controller has 8 analog inputs, 2 analog outputs and 1 frequency output, but 3 analog outputs are required.

### SOLUTION

The room temperature sensor and valve position feedback potentiometers are monitored by the eight room controller analog inputs, and the supply air and the auxiliary supply air valves are controlled by the two 1-10 VDC analog outputs.

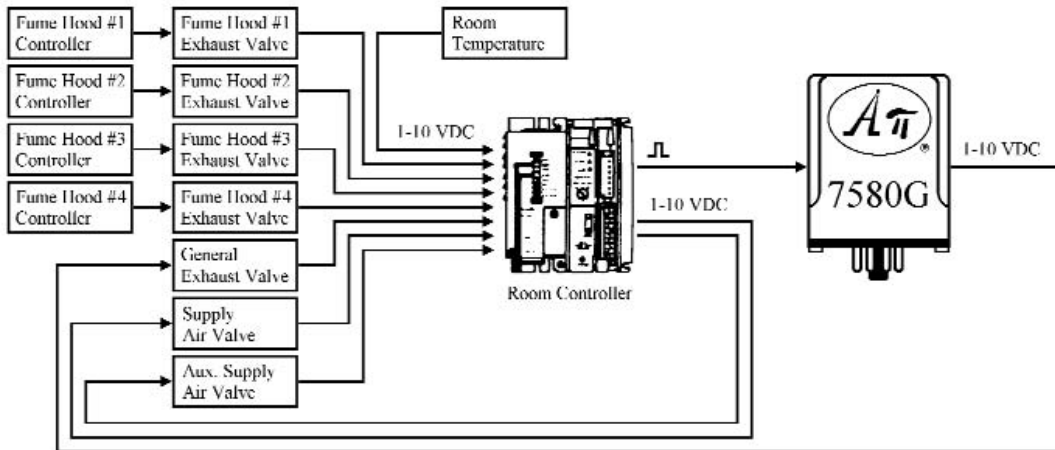

## Frequently Asked Questions

We have a PNP proximity sensor powered by the 18 VDC API 7580 G loop supply. It reads the flywheel gear teeth and sends a frequency signal to the API 7580 G and works fine throughout the range. However, if the wheel is stopped with a tooth in-line with the sensor, the output will stay high (PNP output) and the API 7580 G output will go high to the maximum of the range. How can we prevent this?

The +18 volt loop supply from the API 7580 G has a maximum ripple of 1.5 V<sub>p-p</sub> so the high output from the prox sensor will have this ripple. The signal input to the 7580 G has a capacitor in series so any DC input charges and then opens the circuit. However, with the ripple, there will be a 50/60 Hertz signal present.

You must use a magnetic pick-up in place of the proximity sensor since the amplitude signal from the magnetic pick-up will decrease as the flywheel slows down and when stopped, there will be no amplitude even with a tooth in-line with the sensor head. The magnetic pick-up generates its own signal as the field changes. When the field stops changing, the signal goes to zero.

API maintains a constant effort to upgrade and improve its products. Specifications are subject to change without notice. Consult factory for your specific requirements.

Frequency