

Loop-Powered Passive Isolator Dual Channel

API DPI-2



Two Inputs: 4-20 mADC
Two Outputs: 4-20 mA DC

- 2 Fully Independent Loop Powered Isolators
- 1000 Ω Output Drive Capability
- Calibration Unaffected by Change in Load
- Compact 22.5 mm Wide DIN Style Case
- Output LoopTracker® LED



Applications

- Isolate 4-20 mA Process Signals
- Isolate Two Loops With One API DPI-2
- Eliminate Ground Loops, Reduce Noise Effects

Specifications

Inputs

Channel A: 4 to 20 mADC
Channel B: 4 to 20 mADC

Input Voltage Burden

See graph on back

Outputs

Channel A: 4 to 20 mADC
Channel B: 4 to 20 mADC

Output Load Capability

Up to 1000 Ω with 20 V compliance at 20 mA depending on the supply voltage of the input loop

Change in Load Effect

Less than $\pm 0.08\%$ of span for load changes from 0 Ω to 1000 Ω

Output Zero and Span

Multiturn potentiometers to compensate for load and lead variations, $\pm 10\%$ of span adjustment range typical

LoopTracker

Continuous indication of current flow in the output loop
LED brightness varies with current level over 4-20 mA range

Accuracy

Combined effects of linearity, hysteresis, and repeatability
 $\pm 0.1\%$ span per $^{\circ}\text{C}$ maximum

Response Time

60 milliseconds typical

Common Mode Rejection

Negligible output effect for 50/60 Hz common mode signals

Isolation

1200 V_{RMS} minimum, input to output

Ambient Temperature Range

-10°C to $+60^{\circ}\text{C}$ operating

Temperature Stability

Better than $\pm 0.2\%$ of span per $^{\circ}\text{C}$

Case Material

Polycarbonate
Gray UL #94V-1 housing and black UL #94V-2 terminals



Description and Features

The API DPI-1 is a two channel loop-powered isolator that accepts two separate 4-20 mADC inputs and provides two linear and isolated 4-20 mA outputs. The API LPI-2 contains two completely independent and identical channels in the same housing. When calculating power usage and reviewing specifications, consider each channel separately. The API LPI-2 derive their operating power from the input loop eliminating the need for external power supplies and additional power wiring.

Due to the unique design, the calibration and linearity of each channel is unaffected by output load changes from 0 to 1000 Ω . The API LPI-2 provides a cost effective, drop-in solution for eliminating the ground loops and noise problems commonly found in process loops.

API exclusive features include two **LoopTracker** LEDs for each channel. The LoopTracker LED varies in intensity with changes in the process input signal. The LED will extinguish if either the input or output loops should open. Monitoring the state of these LEDs can provide a quick visual picture of your process loop and saves time during initial startup and/or troubleshooting.

The API DPI-2 is factory calibrated and should not require re-calibration in the field for loads up to 1000 Ω . Each channel is totally independent from the other and each input is optically isolated from its corresponding output.

Should re-calibration (fine-tuning) be desired, independent Zero and Span controls for each channel are accessible through the front of the unit.

The API DPI-2 is designed to mount on an industry-standard DIN rail. The narrow 22.5 mm DIN style housing allows for side-by-side mounting of multiple modules for maximum I/O density with as many as 36 channels (18 modules) in a 19-inch rack.

Models & Options

Factory Configured for 4-20 mA input and output

API DPI-2 Loop-powered 4-20 mA isolator, 2 channel

Optional—Add to end of model number

U Conformal coating for moisture resistance

Accessories—Order as separate line item

API TK36 DIN rail, 35 mm W x 39" L, aluminum

MOD-TRONIC
INSTRUMENTS LIMITED

1 Delta Park Blvd #12
Brampton, ON L6T 5G1
905-457-6322 or 800-794-5883
www.mod-tronic.com



DC Input

ELECTRICAL CONNECTIONS

WARNING! All wiring must be performed by qualified personnel only. This module is mounted to an industry-standard DIN rail. Use **API TK36 DIN** rail.

Signal Input – Polarity must be observed when connecting the signal input.

Signal Output – Polarity must be observed when connecting the signal output to the load.

API DPI-2 Loop A Input

Terminal 1 negative (-)
Terminal 2 positive (+)

API DPI-2 Loop B Input

Terminal 8 negative (-)
Terminal 7 positive (+)

API DPI-2 Loop A Output

Terminal 4 negative (-)
Terminal 5 positive (+)

API DPI-2 Loop B Output

Terminal 10 negative (-)
Terminal 11 positive (+)

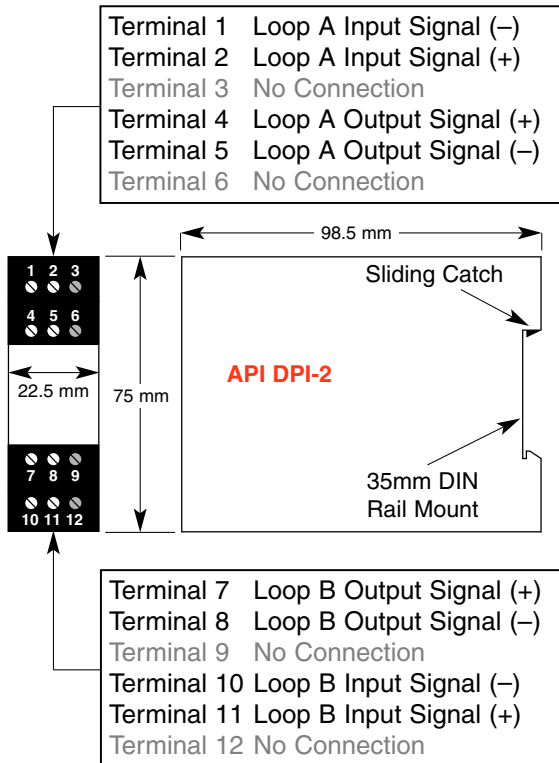

WIRING EXAMPLE

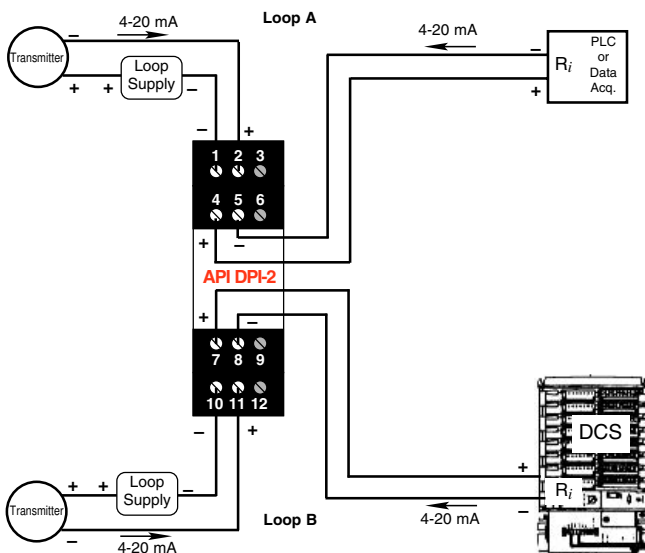

API maintains a constant effort to upgrade and improve its products. Specifications are subject to change without notice. Consult factory for your specific requirements.

INPUT VOLTAGE BURDEN CHART

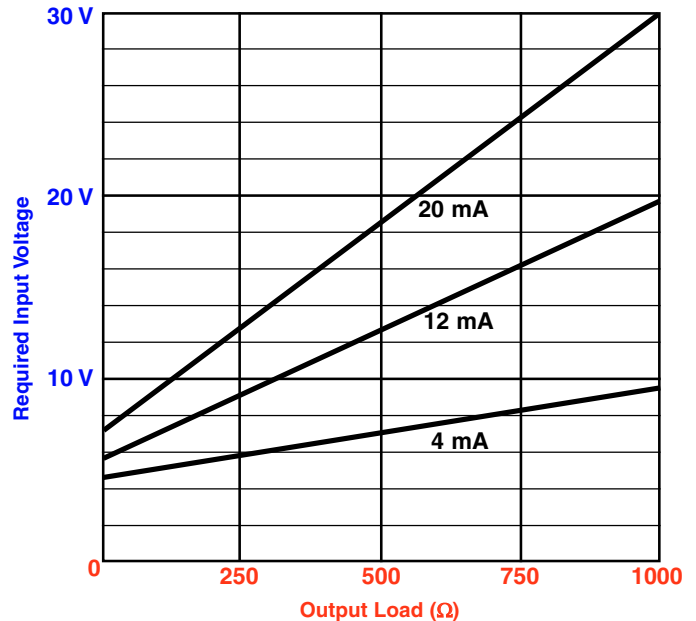

NOTE: The required input voltage is for one channel only.

CALIBRATION

The **API DPI-2** is factory calibrated and should not require recalibration in the field for loads of 0-1000 Ω.

Each channel is totally independent from the other and each input is isolated from its corresponding output.

Should recalibration (fine-tuning) be desired, independent Zero and Span controls for each channel are accessible through the front of the unit to adjust the module's output.

1. Wire unit as shown, apply power to the input and output loops, and allow a minimum 20 minute warm up time.
2. Using an accurate calibration source, provide a 4 mA input to module.
3. Using an accurate measurement device for the output, adjust the Zero potentiometer to 4 mA. The Zero control should only be adjusted when the input signal is at its minimum. This will produce a 4 mA output signal.
4. Using an accurate calibration source, provide 20 mA input to module.
5. Using an accurate measurement device for the output, adjust the Span potentiometer to 20 mA. The Span control should only be adjusted when the input signal is at its maximum. This will produce a 20 mA output signal.
6. Repeat adjustments for the second channel on the **API DPI-2**.

OPERATION

The **API DPI-2** is a passive device which draws a small amount of power from the input loop to operate its isolation circuitry.

The RED **LoopTracker** output LEDs provide a visual indication that the output signal is functioning. It becomes brighter as the input and the corresponding output change from minimum to maximum. The RED LED will only light if the output loop current path is complete. Failure to illuminate or a failure to change in intensity as the process changes may indicate a problem with the module power or signal output wiring.

FAQ

Can the **API DPI-2** have an input of 0-20 mA and an output of 0-20 mA?

No. The loop-powered device requires a minimum of 4 mA to supply power to the module.

What is the maximum 4-20 mA input loop voltage for the **API DPI-2**?

60 VDC is the maximum voltage that can be used to power the input loop.