

Loop-Powered Passive Isolators Single and Dual Channel

API LPI-1, API LPI-2



Input: 4-20 mA DC

Output: 4-20 mA DC

- Single or Twin Pack Fully Isolated Transmitters
- High Output Drive
- Low Input Voltage Burden
- Output LoopTracker® LED
- Functional Test Switch

Applications

- Isolate 4-20 mA Process Signals
- Isolate Two Loops With One API LPI-2
- Eliminate Ground Loops, Reduce Noise Effects

Specifications

Inputs

API LPI-1	One channel:	4 to 20 mADC
API LPI-2	Channel 1:	4 to 20 mADC
	Channel 2:	4 to 20 mADC

System voltages must not exceed socket voltage rating.

Input Voltage Burden

Approximately 9 VDC at 20 mA
See graph on back

Outputs

API LPI-1	One channel:	4 to 20 mADC
API LPI-2	Channel 1:	4 to 20 mADC
	Channel 2:	4 to 20 mADC

Output Drive Capability

Up to 1000 Ω with 20 V compliance at 20 mA at 30 VDC or approximately 750 Ω at 24 VDC depending on the supply voltage of the input loop.
See graph on back.

Change in Load Effect

Less than ±0.08% of span for load changes from 0 Ω to 1000 Ω

Output Zero and Span

Multiturn potentiometers to compensate for load and lead variations
±10% of span adjustment range typical

LoopTracker®

Continuous visual indication of output loop current
LED brightness varies with current level over 4-20 mA range

Functional Test Switch

Momentary contact switch with spring-loaded return
Sets output to calibration reference level of 4 mA to allow testing of module circuits and output loop

Calibration Reference Level

4.0 mA ±0.10 mA
Requires a minimum of 4 mA input current

Isolation

API LPI-1	1200 V _{RMS} minimum, input to output
API LPI-2	1200 V _{RMS} minimum, input to output, channel to channel

Accuracy

Combined effects of linearity, hysteresis, and repeatability
±0.1% span per °C

Response Time

60 milliseconds typical

Common Mode Rejection

Negligible output effect for 50/60 Hz common mode signals

Ambient Temperature Range

-10°C to +60°C operating

Temperature Stability

Better than ±0.2% of span per °C



Description and Features

The **API LPI-1** is a single channel loop-powered isolator that accepts a 4-20 mADC input and provides a linear and isolated output current proportional to the input.

The **API LPI-2** contains two completely independent and identical channels in the same housing. When calculating power usage and reviewing specifications, consider each channel separately.

The **API LPI-1** and each channel of the **API LPI-2** function as two-wire transmitters that derive their operating power from the input loop eliminating the need for external power supplies and additional power wiring.

Due to the unique design, the calibration and linearity of each channel is unaffected by output load changes from 0 to 1000 Ω. The **API LPI-1** and **API LPI-2** provide a cost effective, drop-in solution for eliminating the ground loops and noise problems commonly found in process loops.

API exclusive features include two **LoopTracker** LEDs and a **Functional Test Switch**. The **API LPI-2** has one LED and one switch for each channel.

The LoopTracker LED varies in intensity with changes in the process input signal. The LED will extinguish if either the input or output loops should open. Monitoring the state of these LEDs can provide a quick visual picture of your process loop at all times.

The spring return functional test switch substitutes a stable 4.0 mADC signal into the input loop to allow easy calibration or system testing without the need for external calibrators or wiring modifications. Both the LoopTracker LEDs and functional test switch greatly aid in saving time during initial startup and/or troubleshooting.

The **API LPI-1** and **API LPI-2** modules plug into an industry standard 8-pin socket sold separately. The convenient plug-in design simplifies installation and wiring. Sockets **API 008** and finger-safe **API 008 FS** allow either DIN rail or panel mounting.

Models & Options

Factory configured for 4-20 mA input and output

API LPI-1	Loop-powered 4-20 mA isolator, single channel
API LPI-2	Loop-powered 4-20 mA isolator, 2 channel

Optional—Add to end of model number

U	Conformal coating for moisture resistance
----------	---

Accessories—Order as separate line item

API 008	8-pin socket
API 008 FS	8-pin finger-safe socket
API TK36	DIN rail, 35 mm W x 39" L, aluminum

MOD-TRONIC
INSTRUMENTS LIMITED

1 Delta Park Blvd #12
Brampton, ON L6T 5G1
905-457-6322 or 800-794-5883
www.mod-tronic.com



API LPI-1, API LPI-2

Installation and Setup

DC Input

ELECTRICAL CONNECTIONS

WARNING! All wiring must be performed by qualified personnel only. This module requires an industry-standard 8-pin socket. Order API 008 or finger-safe API 008 FS socket.

Signal Input – Polarity must be observed when connecting the signal input.

Signal Output – Polarity must be observed when connecting the signal output to the load.

API LPI-1 Single Loop

API LPI-1 Input

Terminal 5 negative (-)
Terminal 6 positive (+)

API LPI-1 Output

Terminal 3 negative (-)
Terminal 4 positive (+)

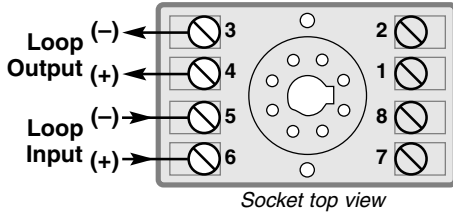

API LPI-2 Dual Loop

API LPI-2 Loop 1 Input

Terminal 5 negative (-)
Terminal 6 positive (+)

API LPI-2 Loop 1 Output

Terminal 3 negative (-)
Terminal 4 positive (+)

API LPI-2 Loop 2 Input

Terminal 8 negative (-)
Terminal 7 positive (+)

API LPI-2 Loop 2 Output

Terminal 2 negative (-)
Terminal 1 positive (+)

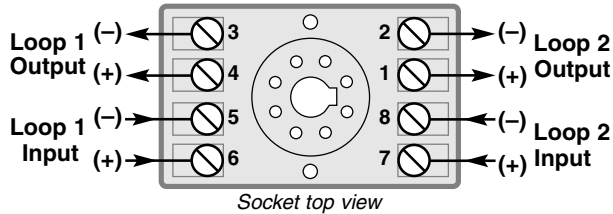

CALIBRATION

The API LPI-1 and API LPI-2 are factory calibrated and should not require recalibration in the field for loads of 0-1000 Ω.

On the API LPI-2, each channel is totally independent from the other and each input is isolated from its corresponding output.

Should recalibration (fine-tuning) be desired, independent Zero and Span controls (one set for each channel of the API LPI-2) are accessible through the top of the unit to adjust the module's output.

1. Wire unit as shown, apply power to the input and output loops, and allow a minimum 20 minute warm up time.
2. Using an accurate calibration source, provide a 4 mA input to module.
3. Using an accurate measurement device for the output, adjust the Zero potentiometer to 4 mA. The Zero control should only be adjusted when the input signal is at its minimum. This will produce a 4 mA output signal.
4. Using an accurate calibration source, provide 20 mA input to module.
5. Using an accurate measurement device for the output, adjust the Span potentiometer to 20 mA. The Span control should only be adjusted when the input signal is at its maximum. This will produce a 20 mA output signal.
6. Repeat adjustments for the second channel on the API LPI-2.

TEST SWITCH

The Test switch may be used to drive the device on the output side of the loop (a panel meter, chart recorder, etc.) with a known good signal which can be used as a system diagnostic aid during initial start-up or during troubleshooting. This test signal is factory set to 4 mA. When the switch is released, the output will return to normal.

INPUT VOLTAGE BURDEN CHART

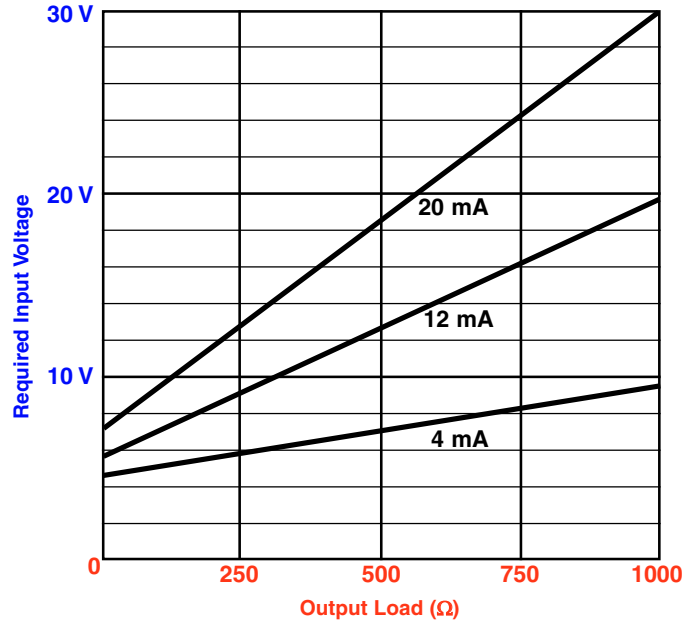

NOTE: The required input voltage is for one channel only.

OPERATION

The API LPI-1 and API LPI-2 are passive devices that draw a small amount of power from the input loop to operate their isolation circuitry.

The RED **LoopTracker** output LED provides a visual indication that the output signal is functioning. It becomes brighter as the input and the corresponding output change from minimum to maximum. The RED LED will only light if the output loop current path is complete. Failure to illuminate or a failure to change in intensity as the process changes may indicate a problem with the module power or signal output wiring.

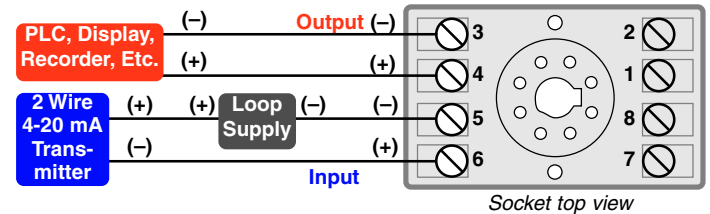

API LPI-1 typical wiring

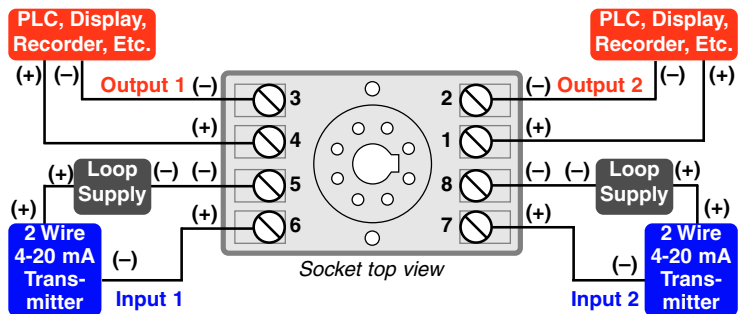

API LPI-2 typical wiring

API maintains a constant effort to upgrade and improve its products. Specifications are subject to change without notice. Consult factory for your specific requirements.



Monitoring and Recording Mass Flow and Mass Flow Ratio

PROBLEM

A natural gas turbine is equipped with water injection to satisfy environmental regulations. Mass flow meters are installed on the fuel and water injection lines to the turbine, and are monitored by a local multi-point indicator which also calculates, displays and provides an analog output of the water to fuel mass flow ratio. The fuel mass flow and the water to fuel mass flow ratio need to be plotted on a 2-pen chart recorder and also be monitored by a computer-based facility management system. The mass flow meters and the multi-point indicator are independently self-powered.

SOLUTION

Use an **API LPI-2** Loop Powered Isolator Twin-Pack module to prevent ground loops.

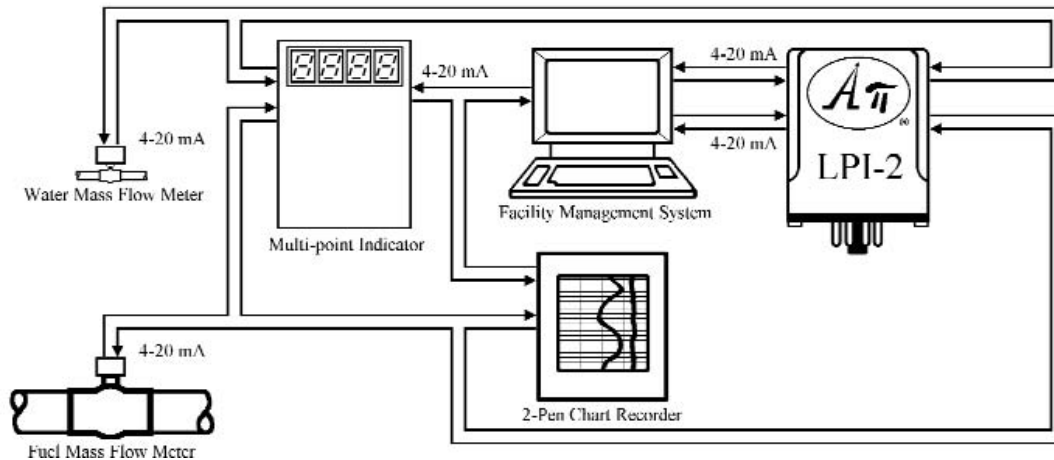

The **API LPI-2** allows the Facility Management System computer to monitor both the inputs and the output of the multi-point indicator without introducing errors due to ground loops.

API Sockets API 008 and API 008 FS

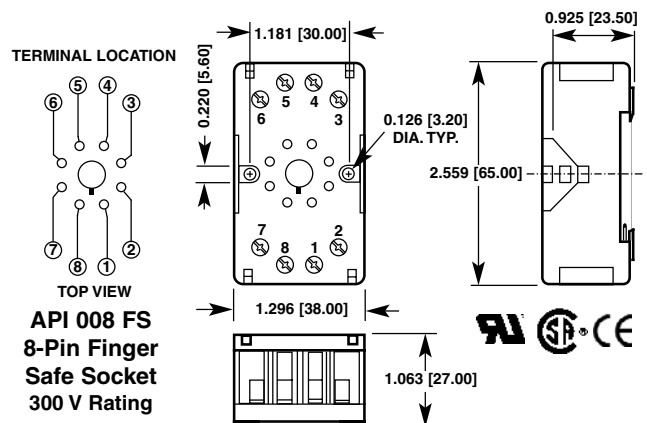
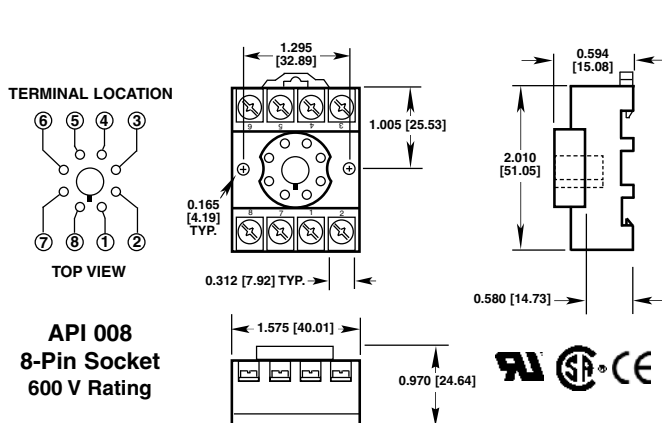

FREE APPLICATION ASSISTANCE
Call Customer Service
800-794-5883



1 Delta Park Blvd #12
Brampton, ON L6T 5G1
905-457-6322 or 800-794-5883
www.mod-tronic.com



What is a Ground Loop?

In a process control loop, a ground loop circuit can develop when each device's ground is tied to a different earth potential thereby allowing current to flow between the grounds by way of the process loop (Figure 1).

Ground loops cause problems by adding or subtracting current or voltage from the process loop. This addition and/or subtraction causes the receiving device to be unable to differentiate between the wanted and unwanted signals and thus can't accurately reflect actual process signals.

The probability of multiple grounds and ground loops being established is especially high when new programmable logic controllers (PLCs) or distributed control systems (DCSs) are installed. With so many conditions within a facility referenced to ground, the likelihood of establishing more than one ground point is great. Thus, if an instrumentation system seems to be acting strangely or erratically, and the problem seems to point toward ground loops, the chore of eliminating all unintended ground connections becomes overwhelming.

Keep in mind that eliminating ground loops just isn't feasible for some instruments, such as thermocouples and some analyzers, because they require a ground to obtain accurate measurements. In addition, some instruments must be grounded to ensure personnel safety.

When ground loops can't be eliminated, the solution lies in the use of signal isolators. These devices break the galvanic path (DC continuity) between all grounds while allowing the analog signal to continue throughout the loop. An isolator also can eliminate the electrical noise of AC continuity (common mode voltage).

Signal isolators can use numerous techniques to achieve their function but the best signal isolators usually employ optical isolators (Figure 2). Regardless of the isolation method used, an isolator must provide input, output, and power isolation. If this three-way isolation is not provided, then an additional ground loop can develop between the isolator's power supply and the process input and/or output signal.

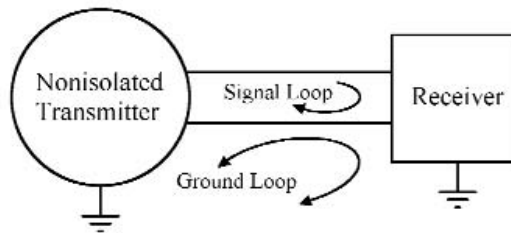

Figure 1. Ground loops may develop with non-isolated transmitters and receivers, resulting in inaccuracy and unreliability.

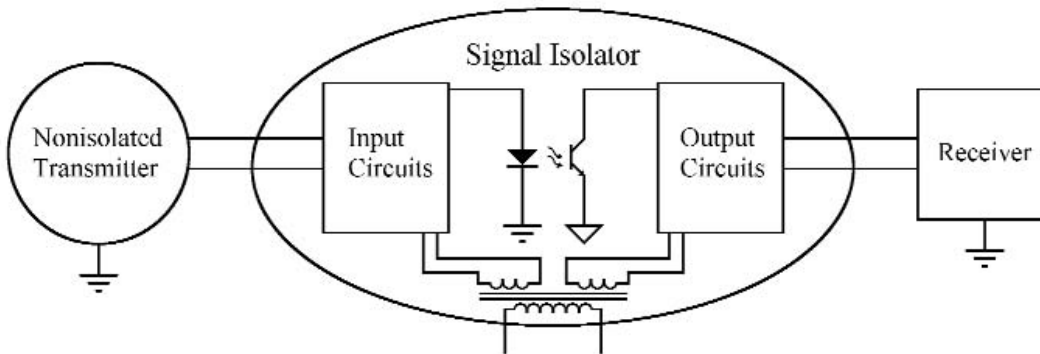

Figure 2. A signal isolator in the process loop blocks ground current to restore signal accuracy and reliability.



FREE APPLICATION ASSISTANCE

Call  Customer Service

800-794-5883

API maintains a constant effort to upgrade and improve its products. Specifications are subject to change without notice. Consult factory for your specific requirements.

MOD-TRONIC
INSTRUMENTS LIMITED

1 Delta Park Blvd #12
Brampton, ON L6T 5G1
905-457-6322 or 800-794-5883
www.mod-tronic.com