

DYNALCO

SWT-2000 Frequency Measurement and Switching Instrument

Operating Manual

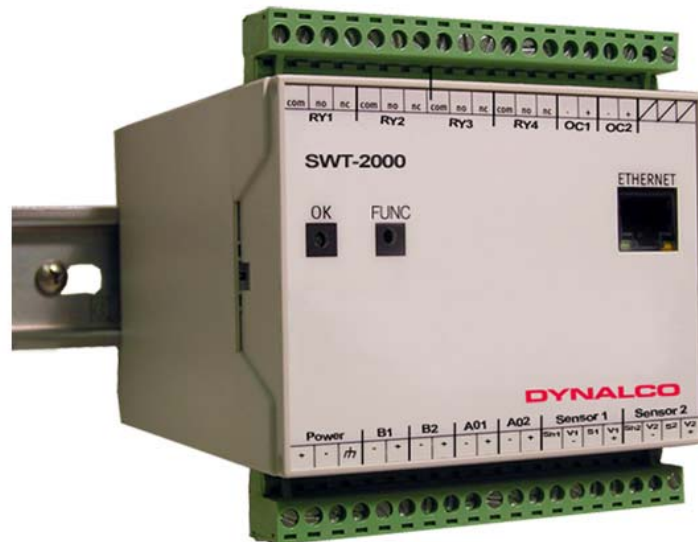

TABLE OF CONTENTS

1.	Product Features	1
2.	Specifications	2
2.1	General	2
2.2	Inputs	2
2.2.1	Sensor Inputs	2
2.3	Binary Inputs	5
2.4	Outputs	5
2.4.1	Analog Outputs	5
2.4.2	Relays Outputs	6
2.4.3	Open Collector Outputs	7
2.5	Data Communication	7
2.5.1	Ethernet	7
2.6	Environment	7
2.6.1	Climatic Conditions	7
2.6.2	Electromagnetic Immunity	7
3.	Principle of Operation	8
3.1	General	8
3.2	Machine Factor	8
4.	Installation	9
5.	Connections	9
5.1	Front View	9
5.1.1	Front View	9
5.1.2	Terminal A	10
5.1.3	Terminal B	11
6.	Configuration via PC Software	12
6.1	Software Concept	12
6.2	PC Settings	12
6.3	Download Configuration Software	12
6.4	Configuration Software	13
6.4.2	Log in	13
6.4.3	Main Window and System Limit Matrix	13
6.4.4	Logging In and Out	13
6.5	Configuration File	13
6.5.1	... creating new	13
6.5.2	... resetting to factory default	14
6.5.3	... loading	14
6.5.4	... saving	14
6.5.5	... printout	14
6.6	Communication with the SWT-2000	14
6.6.1	Read Measured Data	14
6.6.2	Reading Configuration from the SWT-2000	14
6.6.3	Writing a Configuration to the SWT-2000	15
6.6.4	Compare Data	15
6.7	Configuring	15
6.7.1	Speed Sensors	15
6.7.2	Binary Input Configuration	16
6.7.3	Set Measurement Interval	16
6.7.4	Sensor Alarm	16
6.7.5	Machine Factor	17
6.7.6	Dynamic Error	17
6.7.7	Math Function	18
6.7.8	System Limit	19
6.7.9	Relay Outputs	20
6.7.10	Open Collector Outputs	20
6.7.11	Analog Output	21
6.7.12	Copy Parameter Set	22
6.7.13	Change-Over Delay	22
6.8	Settings	22
6.8.1	Ethernet Interface	22
6.8.2	Changing the Password	23
6.9	Info	23
7.	Behavior	24
7.1	Power On	24
7.1.1	Analog Output	24
7.1.2	Relay Output	24
7.1.3	Open Collector Output	24
7.2	Frequency Measurement	25
7.2.1	The Adaptive Trigger Level	25

7.2.2	Signal Failure	26
7.3	Functions	26
7.3.1	"FUNC" Push Button	26
7.3.2	Parameter Sets A, B, C and D	26
7.3.3	Limits	26
7.3.4	Math Function	27
7.3.5	Frequency X2 and X4	28
7.3.6	Relay and Open Collector Latch Function	28
7.3.7	Analog Output	28
7.3.8	Interpretation of System Limit Inputs	29
7.4	Fault Behavior	29
7.4.1	Sensor Error	29
7.4.2	System Alarm	29
7.5	Power Failure	29
7.6	Behavior During Configuration	29
8.	Mechanical Construction / Housing	30
8.2	Mounting	30
9.	Accessories	31

1. Product Features

The model SWT-2000 measures and monitors frequency signals (speed proportional values) in the range 0.025Hz to 50,000Hz.

Available are:

- 2 Frequency Inputs (Speed sensors)
- 2 Analog outputs
- 2 Binary input
- 4 Relays
- 2 Open Collector Outputs
- 4 Parameter sets each having 6 System limits with 4 Limit values
- Sensor monitoring
- System monitoring

The SWT-2000 is configured via Computer (PC) using resident operating software.

2 models are available:

SWT-2000: 2 channel Speed Switch / Transmitter with 4 Relays and 2 Analog outputs 0/4-20mA

SWT-2000AC: (AC Version)

SWT-2000DC: (DC Version)

2. Specifications

2.1 General

Measurement time	2ms / 5ms / 10ms / 20ms / 50ms / 100ms / 200ms / 500ms / 1s / 2s / 5s (Frequency measurements might take longer than the predefined measurement time)			
Supply voltage	AC Version	90...264 VAC (47...63 Hz) / 120VDC ... 370VDC		
	DC Version	18...36 VDC		
Isolation voltage	AC Version	3000 VAC (from AC/DC power supply)		
	DC Version	1500 VDC (from DC/DC converter)		
Isolation	Galvanic isolation between: <ul style="list-style-type: none"> • Supply • Sensor input incl. sensor supply • Binary input 1 • Binary input 2 • Analog output 1 • Analog output 2 • Relay outputs • Open Collector output 1 • Open Collector output 2 • Ethernet interface 			
Power consumption			P Min. (W)	P Max. (W)
	DC Version	18 VDC	3.3	6.6
		24 VDC	3.4	6.7
		36 VDC	3.5	6.8
	AC Version	110 VAC	5.0	11.0
		230 VAC	8.0	14.0
Power supply bridging	DC Version	18 VDC	> 20ms	
		24 VDC		
		36 VDC		
	AC Version	110 VAC	> 20ms	
		230 VAC		
	Operating temperature	AC Version	-25°C...+50°C	
DC Version		-40°C...+70°C		
Storage temperature	AC Version	-40°C...+85°C		
	DC Version			
Weight	AC Version	430g		
	DC Version	390g		
Sealing to DIN EN 60529	IP 20			

2.2 Inputs

2.2.1 Sensor Inputs

An overview how different sensor can be connected is in chapter 5.1.2 Terminal A

Number	2
Frequency range (-3dB)	0.025 Hz ... 50 KHz
Measurement range	Programmable within the frequency range
Measurement accuracy	0.002 %
Resolution (Frequency)	10 ns
Input impedance	> 11.5 kΩ (0.1 Hz → 80 kΩ, 1 KHz → 18.5 kΩ, 10 KHz → 16 kΩ, 50 KHz → 11.6 kΩ)

<p>Input signal for fixed 3V trigger (+/-15%)</p>	<ul style="list-style-type: none"> • Max. Voltage: 80V_{RMS} (226V_{pp}) • Best suited to digital signals • Schmitt Trigger Input (Hysteresis > 1V) • „0“ = Low Level to 1.25V • „1“ = High level from 3V (+/- 15%) • Min. Pulse width: 5µs • NO DC- decoupling
<p>Input signal for adaptive trigger min. 57mVpp (+/-10%) 20mV_{RMS}</p>	<ul style="list-style-type: none"> • Max. Voltage: 80V_{RMS} (226V_{pp}) • DC- decoupling • The Trigger level automatically adapts itself to the input signal in the range +28.5mV to +2V. The Adaptive Trigger improves the signal to noise immunity e.g. where electromagnetic sensors are used. <div data-bbox="630 577 1386 1213" style="text-align: center;"> <p>Min. Trigger level: 57 mVpp +/-10% = 20 mVRMS +/-10% U min. = f(Frequency)</p> </div>

<p>Input signal for adaptive trigger min. 500mVpp (+/-10%) 180mV_{RMS}</p>	<ul style="list-style-type: none"> • Max. Voltage: 80V_{RMS} (226V_{pp}) • DC- decoupling • The Trigger level automatically adapts itself to the input signal in the range +250mV to +2V. The Adaptive Trigger improves the signal to noise immunity e.g. where electromagnetic sensors are used. <div data-bbox="600 378 1388 1008" data-label="Figure"> <p>Min. Trigger level: 500 mVpp +/-10% = 180 mVRMS +/-10% U min. = f(Frequency)</p> </div>
<p>Sensor supply</p>	<ul style="list-style-type: none"> • +14V +/- 0.5V, max. 35mA / Short circuit proof • If the current limit has been activated, then the circuit needs to be disconnected to reset the protection. <p>Typical voltage curve as a function of sensor current</p> <div data-bbox="592 1218 1404 1753" data-label="Figure"> <p>Sensor voltage = f (Sensor current)</p> </div>
<p>Integral pull up resistor</p>	<p>1000Ω to +14V (Only for 2 wire active e.g. NAMUR sensors)</p>
<p>Screen</p>	<p>Terminals are provided for each sensor cable screen (Sh1 and Sh2). These terminals are internally connected to the sensor input / supply 0V.</p>

Sensor monitoring	<p>3 sensor monitoring settings are available in the configuration software:</p> <ul style="list-style-type: none"> No Sensor Monitoring Monitoring of supplied sensors (active Sensor Types) [Also for 2 wire sensors that are supplied via the internal Pull-up resistor (1kΩ) → Sensors drawing current outside of I_{min} or I_{max} are considered to be faulty. $I_{min} = 0.5...35mA$ $I_{max} = 0.5...35mA$ Monitoring of non powered sensors (passive Sensor Types) [For 2 wire sensors such as electromagnetic sensors.] → The sensor is considered to be faulty if the line is broken. Here the sensor impedance is dynamically measured. $Z < 60\ k\Omega = OK$ $Z > 125\ k\Omega = NOT\ OK$
-------------------	--

2.3 Binary Inputs



Number	2 Active Binary Inputs and 1 push button (FUNC – logic OR with Binary input B1)
Level	Logic 0 = 0V....+5V Logic 1 = +15V....+36V
Isolation voltage	1500 V _{RMS}
Input resistance	$R_{min} = 8.2\ k\Omega$

2.4 Outputs

2.4.1 Analog Outputs

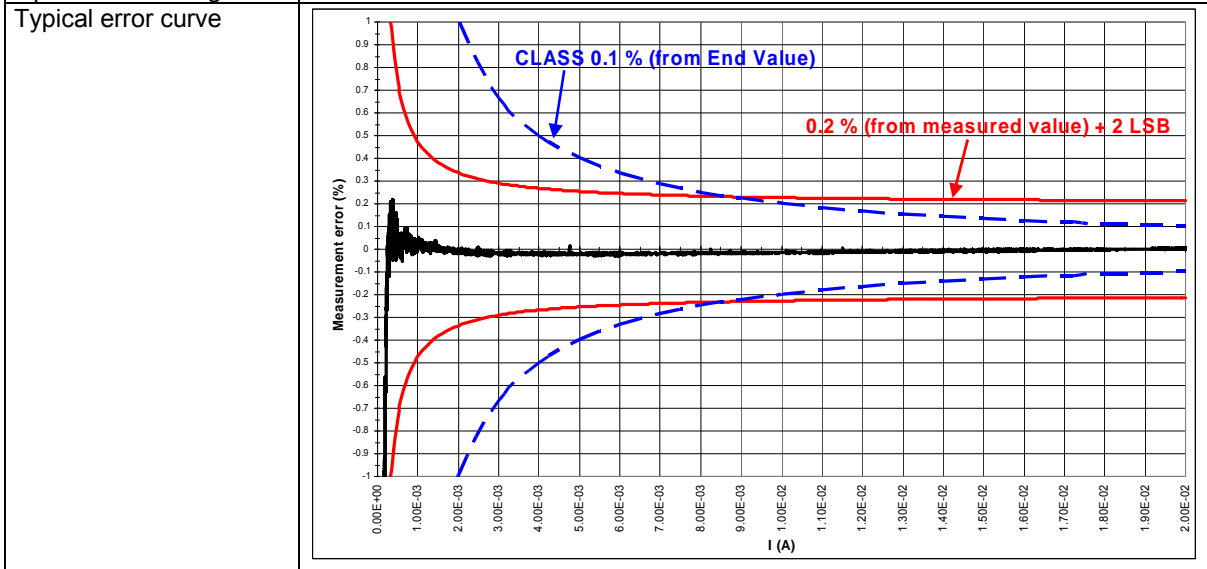
Number	2 Analog outputs
Isolation voltage	1000 VDC
Output type	Current (selectable 0...20 / 4...20mA)
Load	Max. 500Ω
Open circuit voltage	Max. 15V

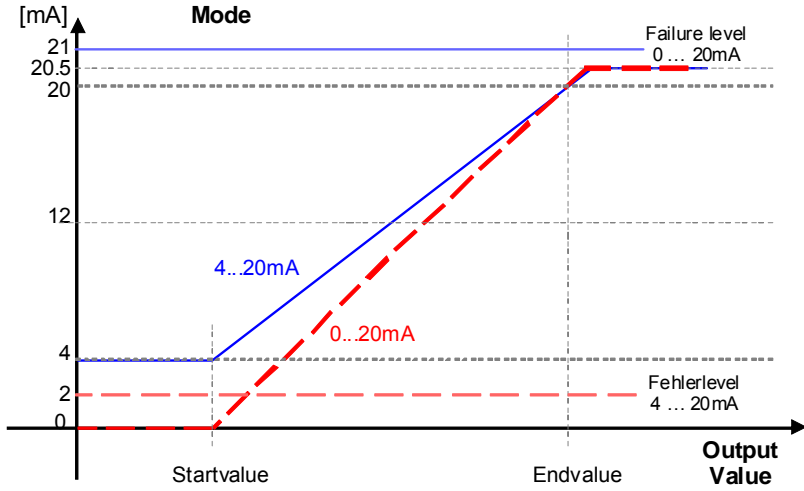

<p>Mode</p>	
<p>Transfer Functions</p>	<p>Start value < or > End value</p> 
<p>Resolution</p>	<p>14 Bit (16384 increments)</p>
<p>Max. Linearity error</p>	<p>2 LSB (Least Significant Bit) ca. 2.7uA</p>
<p>Measuring error</p>	<p>Max. 0.15 % f.m.v. + 2 LSB (-25°C → +50°C) Max. 0.20 % f.m.v. + 2 LSB (-40°C → +70°C)</p>
<p>Accuracy class</p>	<p>0.1 % of the end value</p>
<p>Damping</p>	<p>Hardware time constant T = 4.1 ms 10% → 90% = 8.6 ms (Hardware) Actual time = Hardware time constant + Software setting (configuration)</p>
<p>Temperature Drift</p>	<p>Typ.: 50 ppm/K, max. 120 ppm/K</p>

2.4.2 Relays Outputs

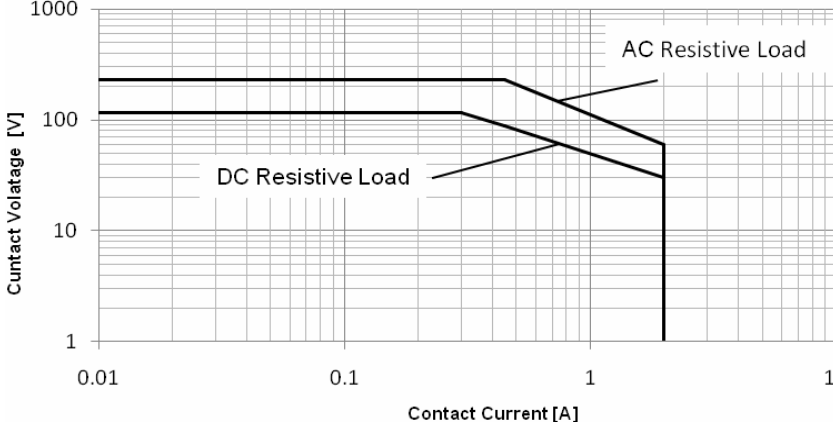
<p>Number</p>	<p>4</p>
<p>Type</p>	<p>Single Pole Double Throw (SPDT)</p>
<p>Functions</p>	<ul style="list-style-type: none"> • May be assigned to System Limit 1..6, Sensor Alarm, Static error Sensor 1 or 2, dynamic error, always on or off. • With or without Hold function (Reset via Binary input) • Fail Safe or Not Fail Safe
<p>Relay - max. switching current</p>	

Reaction time	Effective Measurement interval + max 6 ms
Contact resistance	50 mΩ Max. (Initial contact)
Contact isolation	1500 VAC (coil to contact) 1000 VAC (between open contacts)

2.4.3 Open Collector Outputs

Number	2 Open Collector outputs
Type	Opto-coupler (passive)
External resistance	IC nominal = 15mA ($R_{\text{Pull-up}} = V / I$) <i>Example: $V = 24 \text{ V} \rightarrow R = 1.6 \text{ k}\Omega$</i> IC max. = 30mA
Reaction time	<ul style="list-style-type: none"> As Frequency output: <30 us Effective Measurement interval + max 30 us
Load voltage	V = 5VDC...36VDC
Isolation voltage	1500 VAC
Functions	<ul style="list-style-type: none"> May be assigned to System Limit 1..6, Sensor Alarm, Static error Sensor 1 or 2, dynamic error, always on or off. With or without Hold function (Reset via Binary input) Frequency Sensor 1 or 2, Frequency x2, Frequency x4 (subject to phase shift) Fail Safe or Not Fail Safe
Inverting	Open collector output frequencies are in phase with the input signal.

2.5 Data Communication

2.5.1 Ethernet

Number	1
Physical Layer	Ethernet 10Base-T, IEEE 802.3i
Max cable length	100 m
Transmission rate	10 MBit/s
Connection	Front panel, 8P8C (RJ45)
Usage	Configuration and measurement status
Protocol	Peer to Peer
Connecting cable	Use a crossover cable

2.6 Environment

2.6.1 Climatic Conditions

Standard	DIN 40 040
Operating temperature	See 2.1 General
Storage temperature	See 2.1 General
Relative Humidity	<ul style="list-style-type: none"> 75% average over 1 year; to 90% for max. 30 days. Condensation to be avoided.

2.6.2 Electromagnetic Immunity

Electrostatic discharge	EN 61000-4-2	Contact 6 kV, air 8 kV
Electromagnetic fields	EN 61000-4-3	30 V/m, not modulated and AM 80 % with 1000Hz Sinus wave
Fast transients	EN 61000-4-4	2 kV, repeated 5 kHz duration 15 ms period 300 ms
Slow transients	EN 61000-4-5	Line / line +/- 1kV, earth line +/- 2kV, 1 per minute
Conducted HF	EN 61000-4-6	3 V eff (180 dBuV) 10 kHz – 80 MHz
Mains frequency Magnetic field	EN 61000-4-8	50 Hz, 100 A/m 2 minutes
Voltage dips	EN 61000-4-11	Voltage dips, short interruptions and voltage variations immunity tests

3. Principle of Operation

3.1 General

The model SWT-2000 is microprocessor controlled and operates in accordance with the period measurement principle whereby the duration of the input period is measured during the measurement interval. The reciprocal value based on the average input period corresponds to frequency and hence speed. The relationship between frequency and speed is determined by the Machine Factor.

The status of System Limits is based on various inputs that can be logically combined AND or OR. System Limit inputs may be: both speed inputs, a Math function based on the speed inputs and, the 2 binary inputs. A hysteresis may be set for the speed inputs and Math function individually. The 6 System Limits in each of 4 parameter sets may be individually defined. Parameter sets may be selected via binary inputs. The 4 relays and 2 open collector outputs may be assigned to any System Limit and will react accordingly. The 2 open collectors may alternatively be assigned to frequency x1, x2 or x4. Relay and open collector status may be latched and then reset via binary input.

The system permanently monitors itself. Sensors may in addition be monitored. Sensor error may be used in the configuration to influence System Limits. System error would influence the relays, open collectors and Analog outputs and the front panel LED would go out.

Frequency outputs (Open Collector Outputs) are not influenced by the Machine factor but correspond to the input signal. For frequency X2 or X4 the 2 input signals should ideally be phase shifted by 90 degrees.

Parameter input is via resident PC software and the Ethernet Interface. This may also be used to interrogate the unit, display measurement and unit status.

The Parameters are safely stored in EEPROM.

3.2 Machine Factor

The machine factor establishes the relationship between sensor frequency (Hz) and corresponding speed (RPM).

$$\text{Machine Factor} = \frac{\text{Frequency}}{\text{RPM}}$$

If the # gear teeth and RPM are known, use the following formula to calculate corresponding frequency:

$$\text{Signal Frequency (Hz)} = \frac{(\text{RPM}) \times (\text{Teeth or Discontinuities})}{60}$$

Another way to calculate the machine factor is:

$$\text{Machine Factor} = \frac{(\text{Teeth or Discontinuities})}{60}$$

Note: The above formulas are based on the gear or target turning at the same speed as the machine being monitored, ie: no step up or step down gear ratios involved.

4. Installation

The SWT-2000 may only be installed by competent personnel. Only undamaged and correctly configured units may be used.

Before switching on, check that the supply is within the permissible range.

The Sensor cable screens must be connected terminals „Sh1“ and „Sh2“ respectively so as to minimize the effects of signal noise. These terminals are internally connected with 0V.

Attention: If the password has been changed, there is no way of returning to a factory setup. If the password is forgotten, the unit will need to be returned to Dynalco for re-programming.

5. Connections

5.1 Front View

5.1.1 Front View SWT-2000

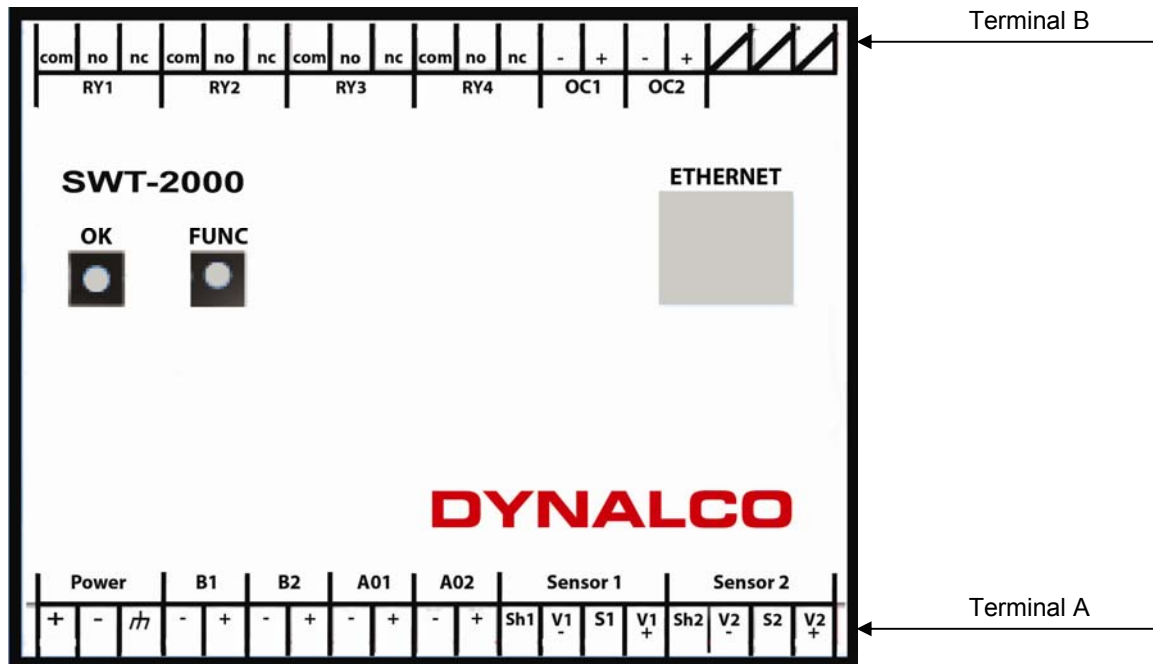

The Ethernet Interface, status LED along with the FUNC push button are located at the front. For communications, see Paragraph 6 Configuration via PC Software

5.1.2 Terminal A

Supply

- + : Input Supply (+)
- : Input Supply (-)
- ⏏ : Earth

Binary Inputs

- B1+ : positive B1
- B1- : negative B1
- B2+ : positive B2
- B2- : negative B2

Sensor connections S1 / S2

- S1 : Sensor input S1
- Sh1 : Screen S1
- V1+ : Sensor Supply S1
- V1- : 0V S1
- S2 : Sensor input S2
- Sh2 : Screen S2
- V2+ : Sensor Supply S2
- V2- : 0V S2

Analog outputs

- AO1+ : positive I1
- AO1- : negative I1
- AO2+ : positive I2
- AO2- : negative I2

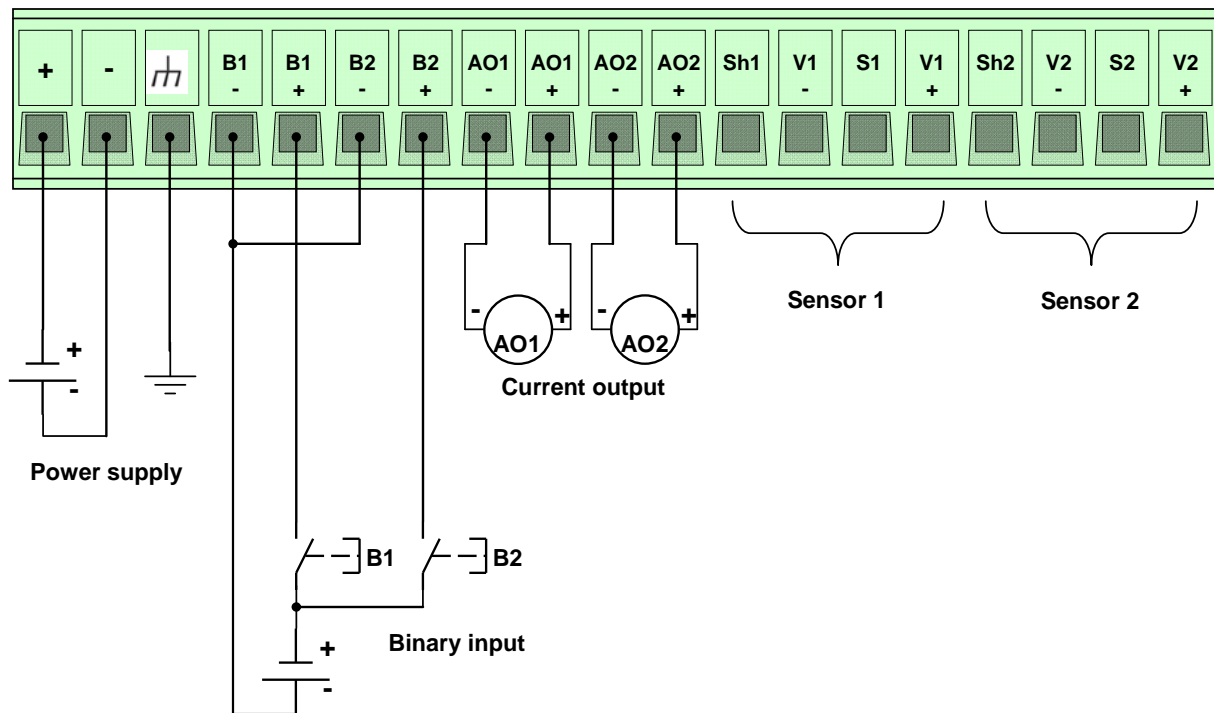

5.1.3 Terminal B

Open Collector Outputs Oc1 / Oc2

- OC1+ : positive Open Collector 1 (Emitter)
- OC1- : negative Open Collector 1 (Collector)
- OC2+ : positive Open Collector 2 (Emitter)
- OC2- : negative Open Collector 2 (Collector)

Relay Outputs R1-R4

- NC : Normally closed
- NO : Normally open
- Com : Common

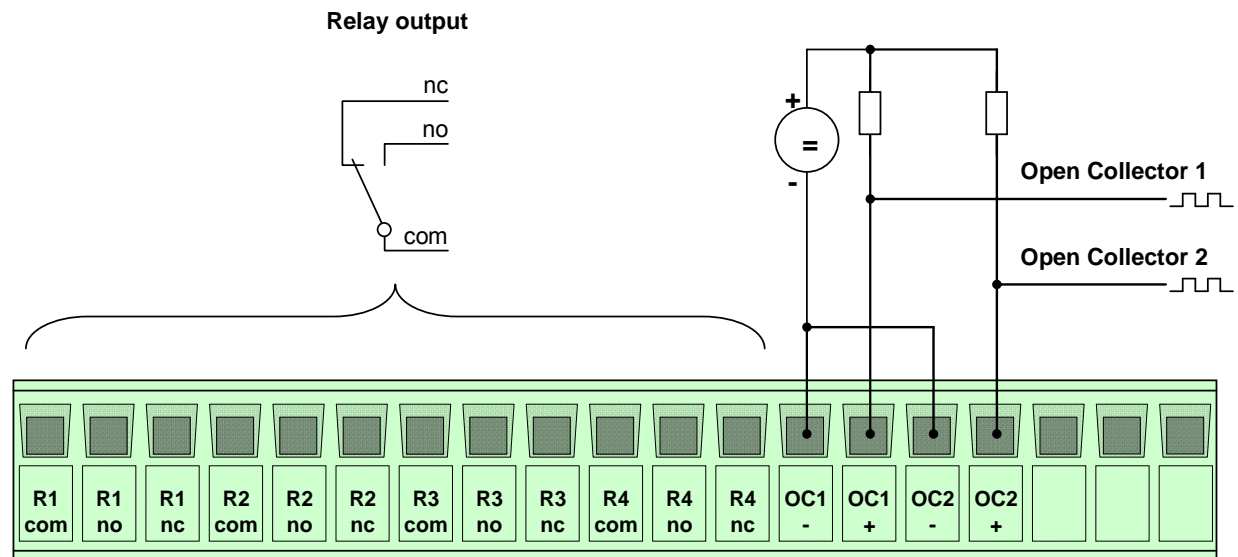

6. Configuration via PC Software

6.1 Software Concept

The SWT-2000 Ethernet connection is used to configure or interrogate the unit. (see Paragraph 9 Accessories) The resident menu driven configuration software is used for unit set up. Normal PC file handling procedures apply and the configuration file can be communicated between computer and SWT-2000.

To run the Software you must have Java Runtime Environment (JRE) 1.5 or higher.

6.2 PC Settings

The PC Ethernet card must first be set correctly. SWT-2000's cannot be used on a network.

Go to Desktop, Settings, Network connections and right click on <Properties>. Right click the Network card you want to use for SWT-2000 comms and select <Properties>.

Select Internet protocol (TCP/IP) and select the Option <IP-Address automatically recognize>

6.3 Download Configuration Software

Connect the Tachometer to your PC using a cross over patch cable. Once connected open your browser and enter the IP address 192.168.1.127/software

An HTML page will open with the Link <Download control program>

Click on the Link. Dependent upon your Internet Explorer configuration you will be asked whether you want to <Open> (Run) or <Save> (Save as) the program.

Direct Execution

Select <Open> and the configuration will be read from the tachometer (can take a few seconds). Once loaded the configuration software will open automatically.

Save As

Select <Save> to save the file in a path of your choice (can take a few seconds).

Open the file from your PC. The configuration software establishes a connection to the SWT-2000 and reads the actual parameters.

6.4 Configuration Software

Configuration User and Process User

SWT-2000 parameters are divided into 2 groups, Configuration and Process parameters. When the program is started, the window shows 3 log in levels, Config user, Process user or Guest. Process and Configuration users require passwords.

As a Guest one only has the right to view measured data or print out actual parameters.

A Process user can perform Guest functions and view and change Process parameters.

The Configuration user has full access and control over all Parameters, Process as well as Configuration.

The factory settings are shown below **Bold**.

6.4.2 Log in

Here you can Log in on three different levels. The standart passwords for Config- and Process- User are:

Config user password	1981
Process user password	1977

6.4.3 Main Window and System Limit Matrix

After successfully logging in you will see the main window used for displaying system and measurement status.

On the left the various System Limit inputs are listed. In the middle the System Limit and alarm status are shown and on the right all outputs and current levels can be seen.

In the middle is a bar called System limit Matrix. Click on this and an overview of the logical status of System Limits, binary inputs and sensor error is shown.

6.4.4 Logging In and Out

To change user level log out via <File> and click on <Log out>, then log in again using the appropriate password.

6.5 Configuration File

6.5.1 ...creating new

To create a new configuration file go to <File>, <New> and click on OK. All parameters are then reset.

Note: If you have not saved the live parameters, they will be lost.

6.5.2 ...resetting to factory default

To reset parameters to factory settings go to <Settings> <Back to factory setup> then click on OK.

Note: If you have not saved the live parameters, they will be lost.

6.5.3 ...loading

To load an existing file go to <File>, <Open> and select the required configuration file.

Note: If you have not saved the live parameters, they will be lost.

6.5.4 ...saving

To save actual parameters go to <File>, <Save as> and choose the path and file name you want to use. Please note that the file name ends in the format *. SWT-2000.

6.5.5 ...printout

To print actual parameters go to <File>, <Print> and choose your printer. 9 pages will be printed.

6.6 *Communication with the SWT-2000*

6.6.1 Read Measured Data

To read actual measured data and unit status go to <Online>, <Start – read measure data>.

Measured data is updated in the Main window with interval defined under <Settings>, <Refresh Interval>.

- ¼ Second
- ½ Second
- 1 Second**
- 2 ½ Seconds
- 5 Seconds
- 10 Seconds

To end the measured data display go to <Online>, <Stop – read measure data>.

6.6.2 Reading Configuration from the SWT-2000

When the configuration software is started the configuration file is automatically transferred to the PC. To up load the file again go to <Online>, <Read parameters> and confirm with Enter.

Note: The live parameter data will be overwritten.

6.6.3 Writing a Configuration to the SWT-2000

When a new configuration file is ready it can be downloaded into the tachometer. Go to <Online>, <Write Parameters> Enter. The new Parameters are then transferred to the Tachometer (can take 10s.). If no connection can be established this will be aborted after 3 attempts.

Note: The actual file in the tachometer will be overwritten.

6.6.4 Compare Data

If you would like to compare a PC configuration file with that in the SWT-2000, first open the file and then go to <Online>, <Compare Data>.

The actual file is then uploaded from the SWT-2000 and compared with the software parameters. A dialogue window will then appear showing whether the files are identical or not.

6.7 Configuring

The factory defaults are written in **bold**.

6.7.1 Speed Sensors

Go to <Configuration>, <Sensor>.

To connect the sensor see Paragraph 5 Connections.

5 Parameters are used to configure the sensor:

Type:	powered / not powered
Resistor:	activated / deactivated
Min. current:	0.5mA ... 35mA
Max. current:	0.5mA ... 35mA
Trigger level:	fixed 3V / min 57mV _{pp} / min 500mV_{pp}

Sensor Type

Powered: The sensor is supplied from the SWT-2000's 14V (+/-0.5V) supply. To use static sensor monitoring, the Min/Max current consumption must be defined.

Not powered: The sensor is not powered by the SWT-2000 and no static monitoring is possible.

Internal pull up resistor

Deactivated: The internal pull up is not in circuit.

Activated: The internal pull up is in circuit.

Current monitoring

When the sensor is supplied from the tachometer upper and lower current limits must be entered. Current consumption outside of the defined limits results in a static sensor error being signaled.

Trigger level

One of 3 modes may be selected. Fixed Trigger (fixed 3V) for digital sensors and two adaptive Triggers (57 mV_{pp} / 500 mV_{pp}) for Analog speed sensors (electromagnetic).

6.7.2 Binary Input Configuration

To configure binary inputs go to <Configuration>, <Binary>.

The following options are available for each binary input:

Logic level: **Active high** / Active low

Function of binary input: **Input for System Limit** / Selection of Control (A/B) (C/D) / Reset latch

Logic level definition

Active High: Logic 1 = binary input 15V ...33V

Active Low: Logic 1 = binary input 0V ... 5V

Binary input for

System Limit input:

Binary input is a constituent part of System Limits.

Parameter set selection:

Binary inputs select the parameter set (PS), see Paragraph 7.3.2 Parameter sets A, B, C and D

Reset latch:

Binary input resets the relays and open collectors.

6.7.3 Set Measurement Interval

Go to <Configuration>, <Measurement time>.

This time interval determines the period during which the speed, parameters, status and outputs are recalculated and set accordingly.

Measurement time: **2ms** / 5ms / 10ms / 20ms / 50ms /
100ms / 200ms / 500ms / 1s / 2s / 5s

6.7.4 Sensor Alarm

Go to <Configuration>, <Sensor alarm>.

There are 3 sources of errors which may be ORed together. Each error source may be included or excluded.

Static error sensor 1:	On / Off
Static error sensor 2:	On / Off
Dynamic error:	On / Off

Box checked = On, unchecked = Off
(see also Paragraph 6.7.1 Speed sensors).

Dynamic Error can only be used when 2 sensors are present. (see Paragraph 6.7.6 Dynamic Error).

6.7.5 Machine Factor

Go to <Configuration>, <System>.

The Machine factor establishes the relationship between sensor frequency and associated machine speed. (see Paragraph 3.2 Machine factor)

The Machine factor may also be set by means of the number of pulses per rev. The 2 parameters have a fixed relationship of factor 60 (Pulses per rev. = Machine factor x 60)

Machine factor:	0.0001 ... 1 ... 999,999
Pulses per revolution:	0.006 ... 60 ... 59,999,940

Once the machine factor has been established all further entries such as speed limits are in machine units e.g. rpm.

6.7.6 Dynamic Error

Go to <Configuration>, <System>.

$$Difference = \left| f_{S1} - f_{S2} \right| \quad \begin{array}{l} f_{S1}: \text{Sensor 1 frequency} \\ f_{S2}: \text{Sensor 2 frequency} \end{array}$$

This function is only available when both sensor inputs are used. This function has influence only on Sensor alarm.

Deviation:	0.0 ... 100.0 ... 999,999
------------	----------------------------------

If the speed difference is greater, then Dynamic error is signalled.

6.7.7 Math Function

Go to <Configuration>, <Math>.

Math function is an additional input available for System Limit.
The following Math functions may be constructed.

S1 – S2	Subtraction of speed values
S2 – S1	
S1 / S2	Division of speed values
S2 / S1	
100% x (S1-S2)/S2	Percentage difference
100% x (S2-S1)/S1	
Variance (S1)	Variance
Variance (S2)	
Acceleration (S1)	Speed value acceleration
Acceleration (S2)	
S1	The speed values are fed through e.g. for the Math function.
S2	

Percentage difference

$$\frac{100 \times (n2 - n1)}{n1} \quad n: \text{Speed}$$

Variance

$$S_x^2 = \frac{1}{j-1} \sum_{i=1}^j (x_i - \bar{x})^2 \quad j = 100$$

Acceleration

$$a = \frac{\Delta v}{\Delta t} = \frac{n_1 - n_{1alt}}{t_{FlankeS1} - t_{FlankeS1alt}} \quad n: \text{Speed}$$

If the variance for S1, S2 or Analog input needs to be calculated, the measurement time must be set to 5ms or higher.

6.7.8 System Limit

Go to <Configuration>, <System Limits>.

Every System Limit has the same 5 logic inputs: Sensor 1, Sensor 2, Math function, Binary input 1, Binary input 2. A hysteresis may be applied to the first 3. Each may be inverted or selected to form part of a logical combination or disabled. The logical combination of inputs may be OR or AND.

Sensor alarm may be additionally combined OR with the System Limit result.

Sensor 1:

Limit low: 0.01 ... **200.0** ... 999,999
Limit high: 0.01 ... **300.0** ... 999,999

Sensor 2

Limit low: 0.01 ... **400.0** ... 999,999
Limit high: 0.01 ... **500.0** ... 999,999

Math Function

Limit low: -999,999 ... **50.0** ... 999,999
Limit high: -999,999 ... **100.0** ... 999,999

Inversion:

Sensor 1: **Over speed** / Under speed
Sensor 2: **Over speed** / Under speed
Math: **Over-run** / Under-run
Binary input 1: **active** / inactive
Binary input 2: **active** / inactive

Inclusion in logical combination:

Sensor 1: **On** / Off System Limit 1
Sensor 2: **On** / Off System Limit 2
Math: **On** / Off System Limit 3
Binary input 1: **On** / Off System Limit 4
Binary input 2: **On** / Off System Limit 4

Logical combination:

Combined **OR** / AND

Hysteresis

Hysteresis may be defined for the first 3 inputs via upper and lower limits. If the lower limit is set higher than the upper limit, the hysteresis is inverted.

Inversion

Every input may be inverted.

Logical combination

The box must be ticked to include the input in the logical combination.

Sensor Alarm

To OR Sensor alarm with the System Limit result the box must be ticked.

6.7.9 Relay Outputs

To configure relay outputs go to <Configuration>, <Relay / Open Collector>.

Relay configuration consists of:

Assignment, the Latch Function and the Fail safe/Not fail safe mode.

System limit 1	Sensor Error
System limit 2	Static S1
System limit 3	Static S2
System limit 4	Dynamic error
System limit 5	Always ON
System limit 6	Always OFF

Possible relay assignment:

Latch Function: Latched / **not latched**
 Safety function: **Fail safe** / Not fail safe

Assignment selection

The selection box is used to choose relay assignment.

Latch Function

Defines whether a relay state should be held until reset.

Safety Function

Defines whether the relay is to operate in Fail safe (deactivate at limit) or not fail safe mode (activate at limit).

6.7.10 Open Collector Outputs

To configure Open Collector outputs go to <Configuration>, <Relay / Open Collector>.

Open Collector configuration consists of:

Assignment, the Latch Function and the Fail safe/Not fail safe mode.

Possible Open Collector assignment:

System Limit 1	Static S2
System Limit 2	Dynamic error
System Limit 3	Always ON
System Limit 4	Always OFF
System Limit 5	Frequency S1
System Limit 6	Frequency S2
Sensor Error	Frequency x2
Static S1	Frequency x4

Latch Function: Latched / **not latched**
 Safety mode: **Fail safe** / Not fail safe

Assignment selection

The selection box is used to choose Open Collector assignment.

Latch Function

Defines whether an Open Collector state should be held until reset.

Safety Function

Defines whether the Open Collector is to operate in Fail safe (deactivate at limit) or not fail safe mode (activate at limit).

6.7.11 Analog Output

To configure Analog outputs go to <Configuration>, <Analog out>.

4 parameters are available: Assignment, Current range, Start and End values and the time constant.

Assignment possibilities:

Sensor 1	Analog output 1
Sensor 2	Analog output 2
Math value	

Current range: 0 ..20mA / **4 .. 20mA**
 Start value: -999,999 ... **0.0** ... +999,999
 End value: -999,999 ... **2.000.0** ... +999'999
 Time constant **0** ... 9.9 in 0.1 Second increments

Assignment selection

The selection box is used to choose Analog Output assignment.

Current range

0 ... 20mA or 4 ... 20mA

Start and End values

Enter the start and end values e.g.

0 (rpm) = 4mA
 2000 (rpm) = 20mA

If the end value is lower than the start value, the output current follows a falling characteristic.

Time constant

Sets a time constant T. The target value is reached after 5xT.
 The output current follows an e- Function.

6.7.12 Copy Parameter Set

Go to <Configuration>, <Copy from Control A>.

A Parameter set may only be copied from Parameter set A. The following Parameters will be copied:

- Machine factor 1 and 2
- Difference
- Math Function selection
- Upper and Lower Limits in System Limits
- System Limit inversion
- Inclusion of input in the logical combination
- Inclusion of Sensor alarm in the logical combination
- Relay / Open Collector assignment
- Relay / Open Collector latch mode
- Relay / Open Collector fail safe mode
- Analog output assignment
- 0..20mA or 4..20mA setting
- Start and End values
- Analog output time constant

6.7.13 Change-Over Delay

Go to <Configuration>, <Delay>.

One change-over delay may be set for the delay in switching from Parameter set B to Parameter set A only.

Delay time: **0** ... 2000 Seconds

Only integer values can be used for the change-over delay.

6.8 Settings

6.8.1 Ethernet Interface

Go to <Settings>, <Interface ...>.

No settings can be made. The PC- SWT-2000 connection is Peer to Peer (PC to PC). SWT-2000's cannot be connected to a network!

For technical data see Paragraph 2.5.1 Ethernet.

DHCP Server	ON / OFF
TCP/IP Adresse	192.168.1.127
TCP/IP Maske	255.255.255.0

6.8.2 Changing the Password

Go to <Settings>, <Change Config user password> or <Change Process user password>.

Changing the password involves entering the old password and the new password twice. To save the password click on <OK>.

The password is now stored in the configuration software.

To change it in the SWT-2000 the data must be downloaded.

A Configuration user may change the Process user password by entering the Configuration user password first. Factory set passwords:

Config User:	1981
Process User	1977

Attention: If the password has been changed, there is no way of returning to a factory setup. If the password is forgotten, the SWT-2000 will need to be returned to Dynalco to be reset.

6.9 Info

To gain information about the SWT-2000 or to enter a Process name <Info>, <Info about>.

An individual Process name may be entered into the text field to the right of <Process ID>, max. 16 characters. (Only alphanumeric characters).

Type:	Tachometer type number
Java version:	Java Version stored in the Tachometer
Firmware:	SWT-2000 Firmware Version
Serial Nr:	SWT-2000's serial no.
Cal. Date:	Calibration date
TCP/IP Address:	SWT-2000's IP Address
JRE Version:	PC's JAVA Runtime

7. Operating Behavior

7.1 Power On

The parameter set e.g. as defined by binary inputs is immediately valid.

7.1.1 Analog Output

Immediately after power on, the output corresponds to the lower range value set. Following the first measurement interval the output corresponds to the measured value.

7.1.2 Relay Output

Up until the first measurement interval is completed, all relays are de-energized. Thereafter they assume the defined condition.

If no input frequency is present then after measurement interval x 2, 0Hz is assumed.

7.1.3 Open Collector Output

Up until the first measurement interval is completed, all Open Collectors are inactive. Thereafter they assume the defined condition.

If the Open Collector is assigned to a frequency, then it immediately assumes the corresponding status.

If no input frequency is present, then after measurement interval x 2, 0Hz is assumed.

7.2 Frequency Measurement

Every frequency measurement starts with the negative edge of the input signal. The last measured edge prior the end of the measurement interval completes the running measurement and immediately starts the next.

An optimum measurement is achieved when the input period is shorter than the measurement interval.

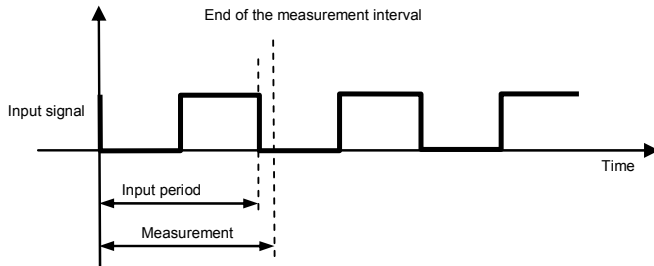

If the input period is greater than the measurement interval, the frequency is calculated as follows:

$$f = \frac{1}{t_{\text{Measurement}} \times n} \quad n: \text{Number of measurement intervals without input signal}$$

This continues until a second negative edge arrives.

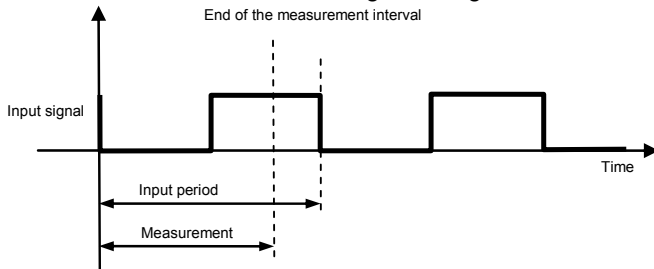

The calculation and adjustment of outputs occurs immediately after the start of the next measurement interval. If the input frequency is lower than the lower limit (0.025Hz), then the output will be zero. The measurement of input frequencies above the upper limit (50kHz) is not guaranteed.

7.2.1 The Adaptive Trigger Level

The trigger level is continuously adjusted for successive pulses. This guarantees that the trigger level can follow a 50% reduction in speed from pulse to pulse. DC offset, resonance and negative pulses have no effect on the triggering

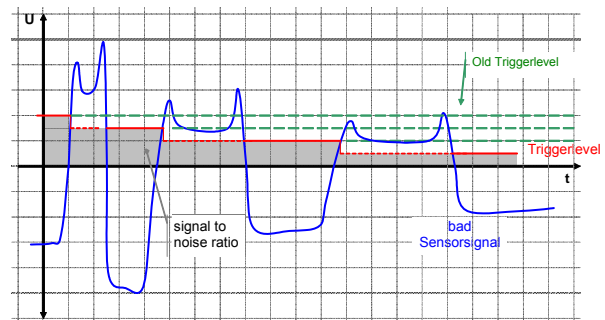

7.2.2 Signal Failure

Signal failure is defined as the sudden transition from an input frequency to no further recognisable pulses. The frequency is then calculated as follows:

$$f = \frac{1}{t_{\text{Measurement}} \times n} \quad n: \text{the number of measurement intervals without an input signal}$$

The measured speed thereby follows an exponential function to the minimum frequency (0.025Hz) and then falls to zero.

7.3 Functions

7.3.1 “FUNC” Push Button

The front panel “FUNC” button is ORed with binary input B1. Pushing this button executes the B1 function.

7.3.2 Parameter Sets A, B, C and D

The binary inputs must be used to change parameter sets. To configure binary inputs see paragraph 6.7.2.

Binary input configur.

Binary input configuration	Status BIN 1	Status BIN 2	Selected Parameter set
Binary input 1 to <Selection of Control A/B> Binary input 2 not to parameter set selection	0 1	X X	A B
Binary input 1 not to parameter set selection Binary input 2 to <Selection of Control C/D>	X X	0 1	C D
Binary input 1 to <Parameter set selection A/B> and Binary input 2 to <Parameter set selection C/D>	0 0 1 1	0 1 0 1	A B C D

For delay in switching between Parameter sets B and A see Paragraph 6.7.13 Change-over delay.

7.3.3 Limits

User defined upper and lower limits allow wide or narrow hysteresis to be set. Unless otherwise required we recommend a hysteresis of 10%.

7.3.4 Math Function

To set a Math function on a speed input please follow the steps below. (Example for Sensor 1):

1. Set the Math function to S1.

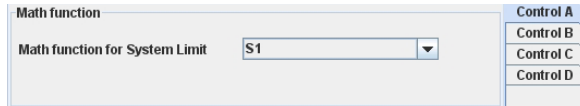

2. Set Math function and Sensor 1 hysteresis.
3. The Sensor – hysteresis gets the higher limit.
4. Math function must be set to under run.
5. All logic inputs must be switched off except Sensor 1 and Math function.
6. The two inputs must be combined OR.

System limit settings

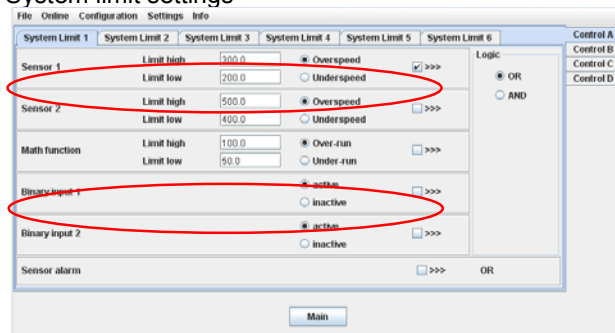

7.3.5 Frequency X2 and X4

Prerequisites for the X2 and X4 function are that the input frequencies are synchronized, they exhibit approximately 90 degrees phase shift and a Mark : Space ratio of approximately 1:1.

The X2 function is an EXOR combination of input frequencies S1 and S2. The X2 output frequency can reach a max value of 35KHz.

The x4 function is based on doubling of the X2 frequency and generates a 10us output pulse each time a positive or negative X2 edge is detected.

The Mark : Space ratio thereby changes with frequency. The x4 output frequency can reach a max value of 35KHz.

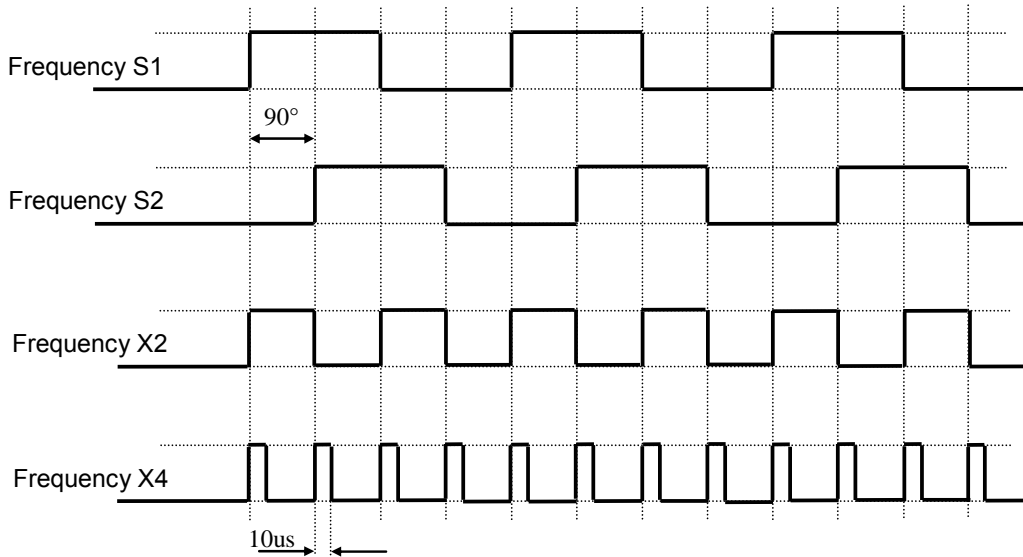

7.3.6 Relay and Open Collector Latch Function

Relays and Open Collectors can be assigned a latch function. If a signal arrives from the assigned function the relay / OC is latched and remains latched until reset via binary input or the <FUNC> button.

Where fail safe mode is selected the deactivated Relay / Open Collector state is held.

7.3.7 Analog Output

If an analog time constant higher than zero is set, with measurement interval of 2ms, then the max. frequency that can be measured is 35KHz.

To measure frequencies higher than 35KHz with time constant higher than zero, a min. measurement interval of 5ms must be selected.

If Sensor Alarm is active that influences the analog output, which assumes the error condition:

Configuration	Output current
0 .. 20mA	21mA
4 .. 20mA	4mA

7.3.8 Interpretation of System Limit Inputs

Upper and lower set points may be set for each of the 3 system limit inputs. In this way a hysteresis is defined. If the upper set point is exceeded then this input assumes a status of 1. When the lower set point is then passed, the status returns to 0. If the actual value lies between the 2 set points then the status is as before.

If a parameters set change takes place when the actual value lies between the set points, the status also remains as before.

7.4 Fault Behavior

7.4.1 Sensor Error

The sensors may be monitored in 3 ways.

- Sensor powered by the SWT-2000 – Sensor supply current monitoring.
If the current falls outside of the defined range, a static error is signalled.
- Sensor not powered by the SWT-2000 – wire break detection.
Static error is signalled when wire breakage occurs. (Impedance measurement of 2 wire sensor)
- 2 speed sensors connected – Dynamic sensor monitoring, i.e. the 2 signals may be compared. If the values differ by more than the defined tolerance, dynamic error is signalled.

The SWT-2000 behaviour in the event of a sensor fault is a function of the software configuration. If sensor monitoring is selected, a fault causes the LED to go off and the analog output (both) go to error status. The Relay and open collector behavior is a function of the configuration.

7.4.2 System Alarm

The microprocessor continuously monitors the following functions for errors: Supply, math functions of the micro controller, RAM, EEPROM.

In the event of a fault the relays are de-activated, the current output goes to 2mA (4-20mA) or 21mA respectively and the Open Collectors become high resistance if assigned to a function other than frequency output. The SWT-2000 then initializes and attempts to run again.

7.5 Power Failure

If the power fails for longer than the bridging time, the outputs are de-activated, i.e. Analog outputs go to 0mA, relays de-activate and the Open Collectors go to high resistance.

As soon as the supply returns to the minimum required, the SWT-2000 commences its initialization routine.

7.6 Behavior During Configuration

During the transmission of configuration or process parameters to the tachometer, it goes into a safe mode, i.e. the outputs assume a defined state. For individual outputs that means:

- Relays: are no longer powered
- Open Collectors: become high resistance
- Analog outputs: assume the fault mode according to the configuration

8. Mechanical Construction / Housing

Dimensions

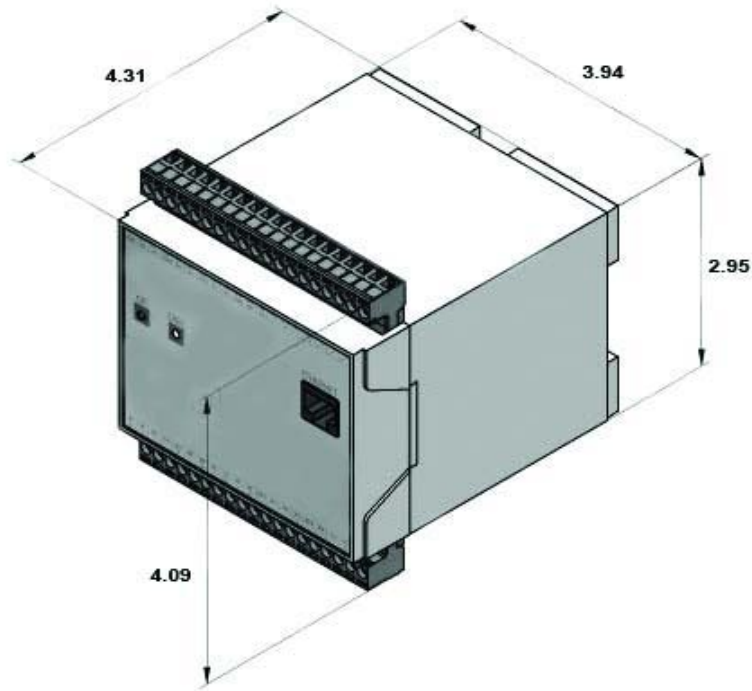

8.2 Mounting

Wall mounting

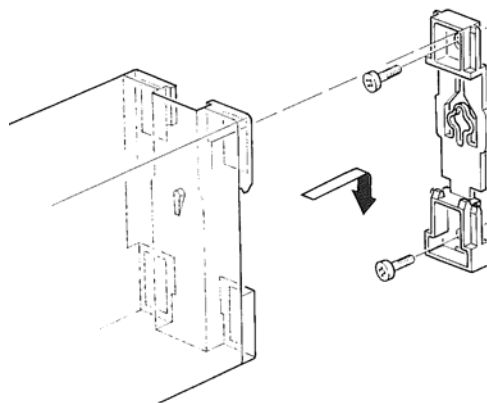

Top hat rail mounting
(as delivered)

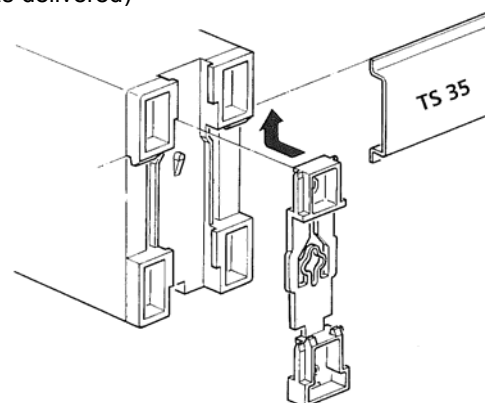

9. Accessories

Interface Cable PC – SWT-2000 (6 Ft crossover): Part No. 270A-105039