

*Simpson*<sup>®</sup>

**505  
High Voltage Insulation Tester  
INSTRUCTION MANUAL**



**SIMPSON ELECTRIC COMPANY** 520 Simpson Avenue  
Lac du Flambeau, WI 54538-0099 (715) 588-3311 FAX (715) 588-3326  
Printed in U.S.A. Part No. 06-116463 Edition 3, 06/07  
Visit us on the web at: [www.simpsonelectric.com](http://www.simpsonelectric.com)

## About this Manual

To the best of our knowledge and at the time written, the information contained in this document is technically correct and the procedures accurate and adequate to operate this instrument in compliance with its original advertised specifications.

## Notes and Safety Information

This Operator's Manual contains warning headings which alert the user to check for hazardous conditions. These appear throughout this manual where applicable and are defined below. To ensure the safety of operating performance of this instrument, these instructions must be adhered to.



Warning, refer to accompanying documents.



Caution, risk of electric shock.

**2000 V CAT II**      Overvoltage category II device



CSA Canadian Standards Association



Indicates EU conformity

## Technical Assistance

SIMPSON ELECTRIC COMPANY offers assistance Monday through Friday 8:00 am to 4:30 pm Central Time. To receive assistance contact Technical Support or Customer Service at (715) 588-3311.  
Internet: <http://www.simpsonelectric.com>

## Warranty and Returns

SIMPSON ELECTRIC COMPANY warrants each instrument and other articles manufactured by it to be free from defects in material and workmanship under normal use and service, its obligation under this warranty being limited to making good at its factory or other article of equipment which shall within one (1) year after delivery of such instrument or other article of equipment to the original purchaser be returned intact to it, or to one of its authorized service centers, with transportation charges prepaid, and which its examination shall disclose to its satisfaction to have been thus defective; this warranty being expressly in lieu of all other warranties expressed or implied and of all other obligations or liabilities on its part, and SIMPSON ELECTRIC COMPANY neither assumes nor authorizes any other persons to assume for it any other liability in connection with the sales of its products.

This warranty shall not apply to any instrument or other article of equipment which shall have been repaired or altered outside the SIMPSON ELECTRIC COMPANY factory or authorized service centers, nor which has been subject to misuse, negligence or accident, incorrect wiring by others, or installation or use not in accord with instructions furnished by the manufacturer.

## NOTES

This manual represents your meter as manufactured at the time of publication. It assumes standard software. Special versions of software may be fitted, in which case you will be provided with additional details.

The apparatus has been designed and tested in accordance with EN 61010-1, "Safety Requirements for Electrical Equipment for Measurement, Control and Laboratory Use." This operating guide contains information and warnings that must be followed by the user to ensure safe operation and to maintain the apparatus in a safe condition.

We reserve the right to make changes and improvements to the product without obligation to incorporate these changes and improvements into units previously shipped.

# Contents

|     |  |    |
|-----|--|----|
| 1.  | CONTROLS AND INDICATORS .....                          | 5  |
| 2.  | SAFETY PRECAUTIONS .....                               | 5  |
|     | 2.1 Repair and Parts Replacement .....                 | 5  |
|     | 2.2 Errors and Extraordinary Strains .....             | 6  |
|     | 2.3 Safety Symbols .....                               | 6  |
| 3.  | APPLICATIONS .....                                     | 6  |
| 4.  | INITIAL START-UP .....                                 | 7  |
|     | 4.1 Battery Installation .....                         | 7  |
|     | 4.2 Testing the Batteries .....                        | 7  |
|     | 4.3 Switching the Tester On and Off .....              | 7  |
|     | 4.4 Analog Display .....                               | 8  |
| 5.  | DIRECT AND ALTERNATING VOLTAGE MEASUREMENTS .....      | 8  |
| 6.  | INSULATION RESISTANCE MEASUREMENT .....                | 9  |
|     | 6.1 Measurement Procedure .....                        | 9  |
|     | 6.2 Measurements with the Guard Cable (optional) ..... | 10 |
| 7.  | Characteristic Values .....                            | 10 |
|     | 7.1 Specifications .....                               | 11 |
| 8.  | MAINTENANCE .....                                      | 12 |
|     | 8.1 Batteries .....                                    | 12 |
|     | 8.2 Housing .....                                      | 12 |
|     | 8.3 Measurement Cables .....                           | 12 |
|     | 8.4 Repair .....                                       | 13 |
| 9.  | FACTORY SERVICE .....                                  | 13 |
| 10. | TECHNICAL ASSISTANCE .....                             | 13 |
| 11. | NIST CERTIFICATION .....                               | 13 |

stances, because this may cause a reduction in insulation performance. The permanently connected test cables are double insulated. Inspect measurement cables on a regular basis. Thoroughly inspect cables every 6 to 12 months.



Even if measuring cables are slightly damaged, send tester to factory for repair. See paragraph 9.

## 8.4 Repair

---

Voltage conducting parts may be exposed when instrument is opened. Instrument must be disconnected from measuring circuit before repair, replacement of parts or balancing. If repair of an open, live instrument is unavoidable, instrument must be repaired by trained personnel who are familiar with the risks involved.

## 9. FACTORY SERVICE

---

Special training and facilities are required for servicing or repairing Model 505 Insulation Tester. When the tester does not appear to be functioning properly, return it to Simpson Electric at 853 Dundee Ave, Elgin IL 60102 or call Simpson Customer Service at (847) 697-2260.

## 10. TECHNICAL ASSISTANCE

---

SIMPSON ELECTRIC COMPANY offers assistance Monday thru Friday 7:30 am to 5:00 pm Central Time. Contact Technical Support or Customer Service at (847) 697-2260.

## 11. NIST CERTIFICATION

---

Simpson Electric Company Standards Lab has the technical expertise and proper facility to handle National Institute of Standards and Technology (NIST) certification. Simpson's Quality Assurance Calibration System satisfies the requirements of MIL-I-45208A, MIL-I-45662A and ANSI/NCSL Z540-1-1994. To certify that your instrument has been calibrated to the manufactures specifications under controlled environmental conditions, for a nominal charge, call Simpson's Customer Service Representative at (847) 697-2260.

### Ambient Conditions:

Operating Temp. 32° F (0° C) to 104° F (40° C)  
Relative Humidity Max. 75%, no accumulation of moisture  
Elevation to 2000 m

### Electrical Safety:

Protection Class II  
Test Voltage ≈ 8.5 kV  
Overvoltage Category II  
Contamination Level 2  
Protection IP 52

Interference Emission EN 50 081-1: 1992  
Interference Immunity EN 50 082-1: 1992

### Mechanical Design:

Dimensions: W 11.41" (290 mm) x D 9.84" (250 mm) x H 5.51" (140 mm)  
Weight: 7 LBS (3.4 kg) with batteries

Making Capacity for Insulation Resistance  
Measurement Response Time: < 100 GΩ < 3 s;  
> 100 GΩ < 8 s  
also valid for test voltage or measuring range changes

## 8. MAINTENANCE



Before replacing batteries completely disconnect the device from all external power circuits. For transportation and maintenance purposes it is recommended that the Range Selector switch be set to the OFF/ V position, in order to prevent unintentional activation.

### 8.1 Batteries

Batteries should be checked. Discharged or corroded batteries must be removed from battery compartment. If leakage occurs at batteries, battery electrolyte must be completely removed and batteries replaced.

Batteries must be replaced when:

- pointer no longer points to battery symbol when Range Selector switch is set to battery test position.
- green LED for selected test voltage does not light.

Replace batteries as described in paragraph 4.1.

### 8.2 Housing

No special maintenance is required for the housing. Keep outer surfaces clean and dry. Use a damp cloth for cleaning. Avoid use of cleansers, abrasives or solvents.

### 8.3 Measurement Cables

Damaged or buckled measurement cables may not be used under any circum-

## 1. CONTROLS AND INDICATORS

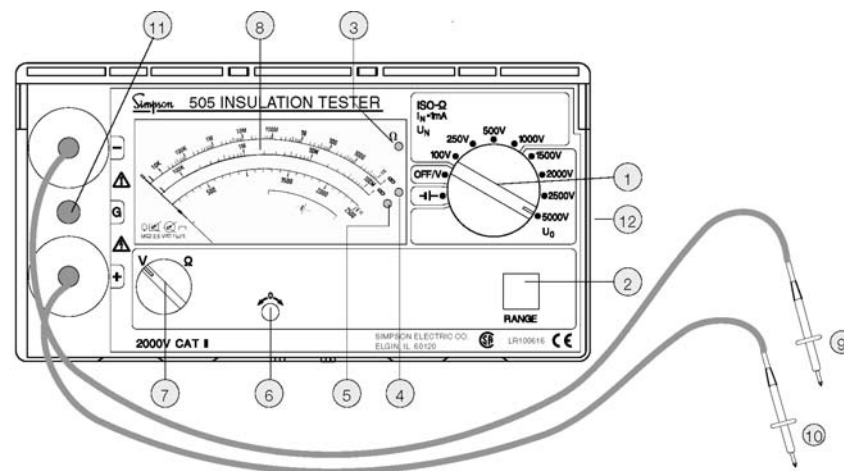

1. Range Selector Switch for test voltage, battery test and power supply interruption
2. Range Key for measuring range selection
3. Ω indicator LED -green: valid measurement  
-off: invalid measurement, battery too weak
4. Upper Range LED: indicates 1 TΩ scale is selected
5. Lower Range LED: indicates 100 MΩ scale is selected
6. Adjustor Screw for mechanical zero adjustment
7. Function Selector Switch for voltage or insulation resistance measurements
8. Analog Display
9. Test Probe Minus Measurement Cable
10. Test Probe Positive Measurement Cable
11. Guard Cable Connector Jack
12. Battery Module

## 2. SAFETY PRECAUTIONS

Simpson's 505 Insulation Tester is manufactured and tested in accordance with the following standards:

IEC 1010-1/EN 61010-1,  
IEC 61557/EN 61557

In order to maintain flawless technical safety conditions and to assure safe use, read the operating instructions carefully before using your instrument.

### 2.1 Repair and Parts Replacement

Voltage conducting parts may be exposed when the instrument is opened. The instrument must be disconnected from all sources of voltage before repair or replacement of parts. If the repair of an open, live instrument is unavoidable instrument must be repaired by trained personnel who are familiar with the risks involved.

## 2.2 Errors and Extraordinary Strains

If suspected that the instrument is no longer operating safely, do not use. Send the instrument in for repair; see paragraph 8.4.

Instrument will not operate safely if:

- measurement cables are damaged,
- the instrument demonstrates visible damage,
- the pointer no longer responds,
- one of the LEDs is defective,
- the instrument no longer functions,
- after lengthy periods of storage under unfavorable conditions.

Observe the following safety precautions:

- Operate Instrument with batteries or storage batteries. Do not use AC Line connected power supplies as they are life endangering.
- Watch carefully for unexpected voltages at devices under test. (For example, capacitors can be dangerously charged.)
- Make certain that measurement cables are in flawless condition, e.g. no damage to insulation, no creases, no interruptions etc.



### High Voltage!

Do not touch the test probes or the device under test during voltage testing!  
High-voltage of up to 5 kV is present!



### Accumulation of Moisture

Avoid any accumulation of moisture on the tester, on the measurement cables or on the unit, because leakage currents may be caused by high-voltages at exposed surfaces. Even isolated components may carry high-voltages.

### NOTE: Overvoltage Influence

If the reversible fuse (PTC thermistor) responds to an overvoltage or an extraneous voltage, do not resume measurement until a cool-down period of approximately 2 minutes is observed.

## 2.3 Safety Symbols

Safety symbols are shown and explained on inside front cover of this manual.

## 3. APPLICATIONS

The MODEL 505 Insulation Tester complies with regulation IEC 61557/EN 61557 "Measuring and Monitoring Equipment for the Testing of Electrical Safety in Systems with Nominal Voltages of up to AC 1000 V and DC 1500 V".

Part 2, insulation resistance testers.

It is suited to measure insulation resistance for devices and systems in a voltage-free condition with nominal voltages of up to 1000 V. It is also suited for measuring insulation resistance of up to 1 TΩ with open-circuit voltages of up to 5000 V.

## Direct and Alternating Voltage

| Measuring Range  | Frequency   | Internal Resistance | Max. Allowable Voltage    | Inherent Deviation <sup>1)</sup> |
|------------------|-------------|---------------------|---------------------------|----------------------------------|
| 0...2000 V AC/DC | 15...500 Hz | 5 M Ω               | 2200 V AC/DC<br>max. 10 s | ± 5%                             |

## Protective Devices

| Terminal   | Internal Resistance                      | Max. Allowable Voltage   | Protective Device   |
|--|--|--|---|
| - Measurement Cable                              | —  | —  | via grounded damping diodes   |
| + Measurement Cable<br>Insulation<br>Measurement | —  | to -meas. cable:<br>to guard cable:<br>2000 V AC/DC<br>max. 10 s | diodes in high-voltage cascade, PTC thermistor <sup>2)</sup> and series resistors |
| Guard Cable                                      | between guard and meas. cables<br>90 k Ω | to -meas. cable<br>2000 V AC/DC<br>max. 10 s                     | PTC thermistor <sup>2)</sup> and series resistors                                 |
| Battery  | —  | 10 V   | pole protection with diodes<br>voltage limiting in battery charger (optional)     |

1) as related to scale length

2) PTC thermistor cool-down period until start of new measurement:  
at least two minutes must be observed!

## 7.1 Specifications

### Display:

Movement core-magnet moving-coil mechanism  
Scale Length 111.5 mm (longest scale)

### Reference Conditions:

Ambient Temp. 73° F (23° C) ± 4° F (2° C)  
Relative Humidity 45 ... 55%  
Meas. Magnitude Frequency 60 Hz (for voltage measurement)  
Mains Voltage Waveform sine, deviation between effective and rectified value < 1%  
Battery Voltage 8 V ± 1%  
Operational Position horizontal

### Power Supply:

Battery or Storage Battery 6 ea. 1.5V single cell "D" size batteries  
Working Range 6 V ... 10 V  
Battery Service Life 7500 measurements 1000 V test voltage with 1 MΩ measuring shunt, 15,000 measurements at 500 V test voltage with 500 kΩ measuring shunt, with 5 s measurement and 25 s pause

## 6.2 Measurements with the Guard Cable (optional)

The measurement of very high impedance resistances presupposes extremely small measurement currents, and problems can occur due to influences such as electromagnetic fields, moisture or surface currents. For this reason, the measurement set-up must be accurate.

For measurements over 10 G $\Omega$ , the optional guard cable (cat. no. 45065) is recommended. It must be used for measurements from 100 G $\Omega$  ...1 T $\Omega$  in order to prevent inaccurate measurement results caused by surface currents. The guard rings prevent current at the surface of the insulation material from flowing from the + measurement cable to the – measurement cable instead of through the insulation material itself.

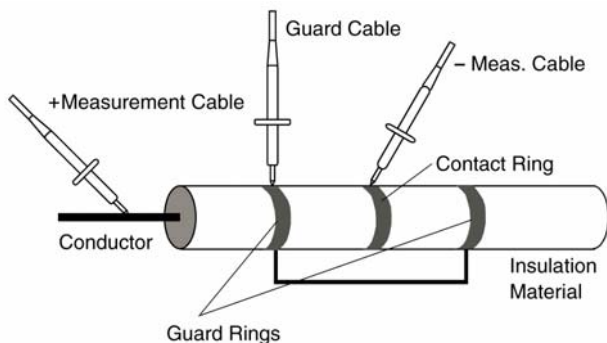

1. Insert guard cable plug into appropriate jack at tester.
2. Plug alligator clip onto guard cable test probe.
3. Clip alligator clip onto guard ring located between both measuring points of insulation material to be measured.
4. See paragraph 6.2 for measurement procedures.

## 7. Characteristic Values

### Insulation Resistance

| Meas. Range                          | Nominal Range of Use                 | Nom./Open-Circuit Voltage $U_N / U_0$                 | Nominal Current $I_N$                | S-C Current $I_K$ | Inherent Deviation <sup>1)</sup> |
|--------------------------------------|--------------------------------------|---|--------------------------------------|-------------------|----------------------------------|
| 100 k $\Omega$ ...<br>100 M $\Omega$ | 100 k $\Omega$ ...<br>10 M $\Omega$  | 100 V<br>250 V<br>500 V<br>1000V                      | 1 mA                                 | 1.3 mA            | $\pm 2.5\%$                      |
| 10 k $\Omega$ ...<br>1 T $\Omega$    | 100 k $\Omega$ ...<br>100 G $\Omega$ | 100/1500 V<br>250/2000 V<br>500/2500 V<br>1000/5000 V | 0.7 mA<br>0.5 mA<br>0.4 mA<br>0.1 mA | 1.3 mA            | $\pm 5\%$                        |

The tester is also equipped with a 2000 V measuring range for direct and alternating voltages. This is especially advantageous for testing for the absence of voltage, and for discharging of capacitive units under test.

## 4. INITIAL START-UP

### 4.1 Battery Installation



Before opening the battery compartment (side panel) be sure that the Function Selector switch is set to the “V” position, and that the Range Selector switch is set to the “OFF/V” position, and that the device is completely disconnected from all external power circuits.

1. Unscrew and remove battery compartment.
2. Remove battery clip.
3. Pull battery holder out of battery compartment.
4. Insert six commercially available 1.5 V “D” size batteries or storage batteries (single cell) into battery holder with polarity as indicated by symbols.
5. Push battery holder back into battery compartment.
6. Push battery clip back over contacts making certain that correct poling is assured.
7. Reinstall battery compartment to the housing in the correct direction (labeling must be legible) and fasten with screws.

### 4.2 Testing the Batteries

After batteries have been installed, or if  $\Omega$  indicator LED fails to light during insulation resistance measurement, test batteries. For battery testing, Range Selector switch must briefly be set to the  $\pm$  position. Deflection of pointer on the analog dial within the  $\pm$  scale during battery test indicates the condition of batteries or storage batteries at an average load of 1000 V test voltage. The position of the Function Selector switch will not affect battery test results. The left end of the scale represents minimum required supply voltage, and the right end represents maximum available supply voltage.

**NOTE:** If pointer only moves into minimal supply voltage range, several measurements can still be performed for test voltages of less than 1000 V, because the battery test is conducted with the same load as is used for a test voltage of 1000V.

### 4.3 Switching the Tester On and Off

As long as the Function Selector switch is set to  $\Omega$  and the Range Selector switch is not in the OFF/ V position, tester remains activated. For transportation and maintenance purposes, it is recommended that the Function Selector switch be set to the V position, and the Range Selector switch be set to the OFF/ V position in order to prevent unintentional activation.

**NOTE:** Be certain that the grip on the Function Selector switch points exactly to “V” or “ $\Omega$ ”. This is especially important during discharging of capacitive devices under test, because voltages are not displayed in intermediate selector switch positions.

## 4.4 Analog Display

Logarithmic representation of the upper resistance scale allows for quick recognition of the magnitude involved. In order to achieve the required accuracy for testing of protective measures, the RANGE key allows for switching to the expanded power limit measuring range of 100 k $\Omega$ ... 100 M $\Omega$ . The orange colored Upper Range and Lower Range LEDs, at the right end of the scale indicate which of the two resistance measuring ranges is currently active.

The  $\Omega$  indicator LED lights green to confirm correct insulation measurement. If LED does not light, test voltage has not been achieved. In this happens test the battery. The two lower scales are for battery testing and voltage measurement, see paragraph 4.2 and 5 respectively.

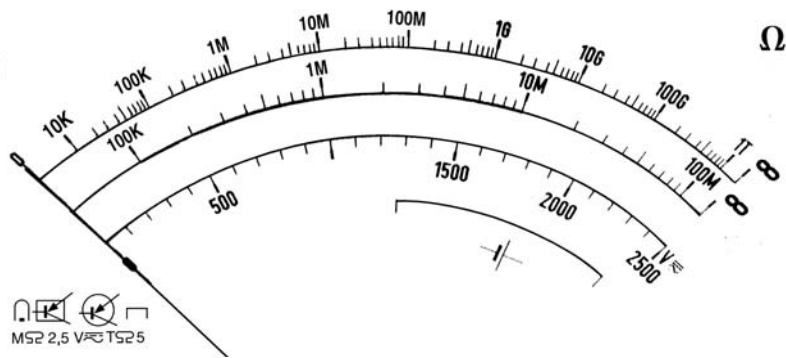

## 5. DIRECT AND ALTERNATING VOLTAGE MEASUREMENTS

Direct voltages and sinusoidal alternating voltages with frequencies ranging from 15 to 500 Hz can be measured with the tester. Deflection of the pointer at the instrument is always positive for direct voltage measurements, regardless of polarity at the connections. Alternating voltage is indicated as an effective value. Voltage measurements are used to test for the absence of voltage before insulation resistance measurements, as well as for the automatic discharge of capacitive devices under test. The voltage drop can be observed at the display.

**NOTE:** Regardless of the position of the Range Selector switch, voltage measurement can always be performed with Function Selector switch in the "V" position (even without batteries).

1. Set Function Selector switch to "V" position.
2. Check that pointer is at "0" in the V scale when the test probes are not connected. Reset the pointer as required using Adjustor screw for mechanical zero adjustment.
3. Position of Range selector switch has no influence on voltage measurements, although we recommend setting it to the OFF/ V position.
4. Contact measuring points with both test probes.
5. Read measurement value at V scale.

**NOTE:** Voltages greater than 2000 V may not be applied. Input resistance for voltage measuring range is equal to 5 M $\Omega$ .

## 6. INSULATION RESISTANCE MEASUREMENT

Be certain that the unit under test is voltage-free before performing measurements; see paragraph 5.

For measurements over 10 G  $\Omega$ , the optional guard cable (cat. no. 45065) is recommended; see paragraph 6.3.

### 6.1 Measurement Procedure

1. Set Function Selector switch to  $\Omega$  position, in order to activate test voltage.
2. A range of either 10 k $\Omega$  ...1 T $\Omega$  or 100 k $\Omega$ ... 100 M $\Omega$  can be pre-selected with the RANGE key.
3. Select the required nominal voltage of 100 V, 250 V, 500 V, 1000 V, 1500 V, 2000 V, 2500 V, or 5000 V with the Range Selector switch depending upon the nominal voltage of the unit under test. The Upper and Lower Range LED's indicated the selected range, 10k $\Omega$ ...1 T $\Omega$  or 100k $\Omega$ ... 100M $\Omega$ . To begin, select the 10 k $\Omega$ ... 1 T $\Omega$  range with the RANGE key. Upper Range LED will light.
4. Contact the measuring point with both test probes and wait until pointer has settled. Depending on the unit under test, this might take up to 30 seconds, if, for example, large capacities (long cables) must be charged.
5. Read the measurement value from the upper scale. If the green LED  $\Omega$  indicator lights, the insulation measurement is valid. If this LED does not light, test voltage has not been achieved. If this happens, test the battery; see paragraph 4.2.
6. In order to achieve the required accuracy for testing of protective measures, select the high resolution range, 100 k $\Omega$ ... 100 M $\Omega$  with the help of the RANGE key. The Lower Range LED lights.
7. Contact the measuring point with both test probes once again.
8. Read the measurement value from the lower scale.



Do not touch conductive ends of test probes when tester has been activated for measurement of insulation resistance.

This may cause an electric shock, which, although not life endagering, causes a clearly distinguishable shock.

When measurements are made at capacitive devices under test, e.g. cables, the unit under test may be charged with voltages of up to approximately 5000 V, depending upon selected nominal voltage. Contact with the unit under test after measurement is, in this event, life endagering!

For this reason the unit under test must be discharged in a controlled fashion by switching Function Selector switch to V and contacting the unit under test with the test probes until measurement display indicates 0 V. Do not reverse the poles of unit under test during discharging, because internal over-voltage protection would otherwise be triggered. If the capacitance to be discharged is greater than 3mF, **poles must not be reversed**, because unit might otherwise be damaged.

#### **NOTE: Overvoltage Influence**

If the reversible fuse (PTC thermistor) responds to an overvoltage or an extraneous voltage, do not resume measurement until a cool-down period of approximately 2 minutes is observed.