

## Falcon F35 Series Digital Panel Meter

- Full 3-1/2 Digit, Bright Red 0.56" (14.2mm) Display
- Broad Range Display Scaling
- Short 2.94" (74.7mm) Deep, 1/8 DIN Case
- Screw Terminal Connector for Easy Installation
- Three User-Selectable Ranges: 4-20mA, 1-5V, 0-10V
- Jumper-Selectable Decimal Point
- Optional Isolated 9-32VDC Power Supply
- Optional Excitation Output of 12VDC or 24VDC



The Falcon Series digital indicators are premium quality 1/8 DIN meters for industrial applications. All Falcon units feature jumper-selectable decimal point (internal and on the connector for remote decimal point) and display scaling, providing wide application flexibility. In addition, signal input ranges are easy to change with jumpers on the main board. The Falcon has a 0.56" bright red LED display for high visibility.

Compactly designed for applications requiring minimal rear panel depth, the Falcon fits a standard 1/8 DIN panel cut-out (92mm x 45mm) and requires less than 3" behind the panel. A screw terminal connector is a standard feature for easy wiring of the power supply and signal input connections.

### Installation and Panel Cutout

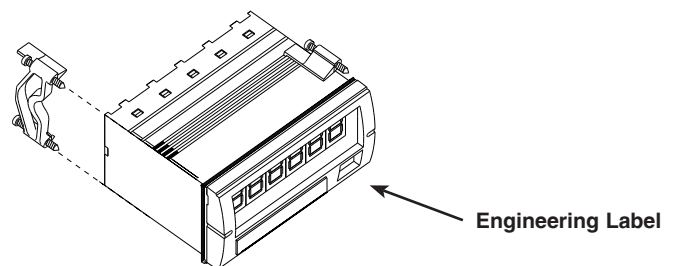
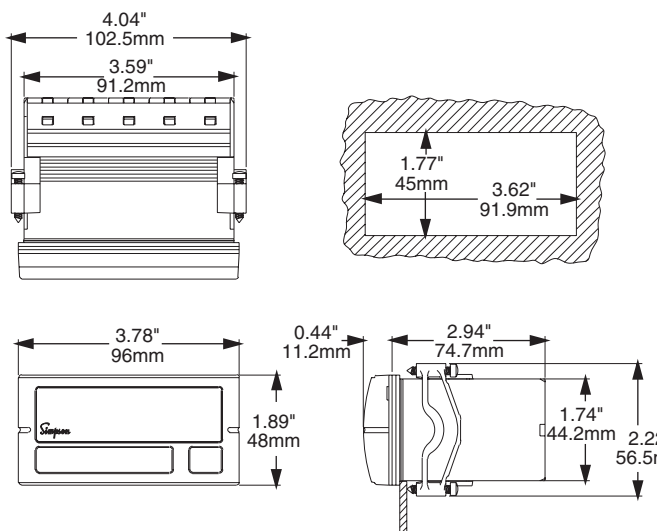

#### Mounting Requirements

The Falcon series 1/8 DIN indicators require a panel cutout of 1.77" (45mm) high by 3.62" (92mm) wide. To install the Falcon into a panel cutout, remove the clips from the side of the meter. Slide the meter through your panel cutout, then slide the mounting clips back on the meter. Press evenly to ensure a proper fit.

#### Engineering Label Placement

If replacement of the engineering unit label is required, place the tip of a ball-point pen into the small hole at the base of the engineering label in the bezel. Slide the label up until it pops out. Grasp and remove. Slide the new label half the distance in, then use the ball-point pen to slide it down into place.

# Specifications

## DISPLAY

**Type:** 7-segment, red LED  
**Height:** 0.56" (14.2mm)  
**Decimal Point:** 3-position programmable, internally or on the terminal block  
**Overrange indication:** most significant digit = "1"; other digits blank  
**Polarity:** Automatic, with "-" indication, "+" indication implied

## POWER REQUIREMENTS

**AC Voltages:** 120 or 220VAC, ±10% 50/60Hz  
**DC Voltages:** 9-32VDC, ±1%  
**Power Consumption:** 3VA

## ACCURACY @25° C

±0.1% of reading ±1 count

## ENVIRONMENTAL

**Operating Temperature:** 0 to 55°C  
**Storage Temperature:** -10 to 60°C  
**Relative Humidity:** 0 to 85% non-condensing  
**Temperature Coefficient:** (±0.01% of input ± 0.05 count)/°C  
**Warm-up Time:** Less than 15 minutes  
**Response Time:** Less than 1 second

## NOISE REJECTION

**NMRR:** 50dB, 50/60Hz  
**CMRR:** (w/1KΩ unbalanced @ 60Hz): 90dB min.

## ANALOG TO DIGITAL CONVERSION

**Technique:** Dual slope integration  
**Rate:** 3 samples per second, nominal

## MECHANICAL

**Bezel:** 3.78"x 1.89" x .44"  
 (96 x 48 x 11.2mm)  
**Depth:** 2.94" (74.7mm)  
**Panel Cut out:** 3.62" X 1.77"  
 (91.9 x 45mm 1/8 DIN)  
**Case Material:** 94V-1, UL rated Noryl®  
**Weight:** 9.0oz (255.1g)

## INPUTS: DC Process

Input Range	Display Resolution	Voltage Drop	Maximum Overload
4-20mA	10μA	0.2V (Input Impedance)	100mA
1-5V	10mV	10MΩ	100V
0-10V	10mV	10MΩ	100V

# Wiring Diagram

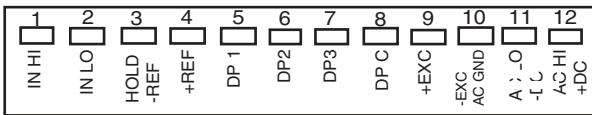

**Input Signal:** Connect the signal to be monitored to the IN HI and IN LO terminals. IN HI is terminal #1, IN LO is terminal #2.

**Supply Power:** Connect the supply power to terminals #11 and #12. Note that if AC power is supplied, terminal #11 is for Neutral, and terminal #12 is for Hot. If DC power is used, terminal #11 is for -DC, and #12 is for +DC.

**Display Hold:** This feature allows you to hold the displayed value indefinitely. A remote switch can be used to make the connection. To activate the display hold, short terminal blocks #3 and #4 (Hold Ref and +Ref). This connection must be kept isolated from other circuitry. To hold multiple units, separate poles of the switch must be used to maintain the isolation.



These instruments are designed for maximum safety to the operator when mounted in a panel according to instructions. They are not to be used unmounted or for exploratory measurements in unknown circuits.



Before switching the instrument on, make sure the supply voltage matches the power source required of the instrument as indicated on the hook-up label affixed to the instrument.

# Decimal Point Selection

**From terminal block:** The decimal point can be set from the rear screw terminal block by connecting the appropriate decimal point (DP 1, 2, 3, ) to the DP C terminal. The J105 jumper must be in the D position (see diagram under "From front panel").

Decimal Point	Connect
1.999	DP C to DP1
19.99	DP C to DP2
199.9	DP C to DP3
1999	No Decimal

**From front panel:** The decimal point can also be selected by removing the front bezel from the meter. Move the push-on jumper J105 across the correct letter.

Decimal Point	Jumper Position at J105
1.999	A
19.99	B
199.9	C
1999	D*
* No Decimal Point	

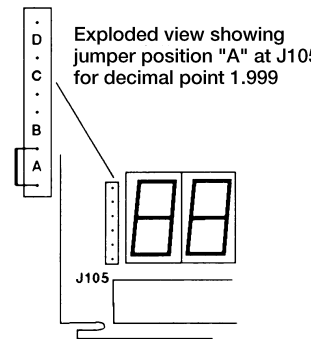

# Process Range Selection

All Falcon Indicators are configured initially per the customer specifications. Range changes can be accomplished as follows:

Disconnect power from the unit. Remove the unit from the panel. Remove the front bezel by inserting slotted screwdriver in the vertical slots on either side of the bezel and then turning to pry the bezel off. Unscrew the two Phillips head screws at either side of the circuit board. Finally, push on the green connector assembly in the back of the unit to slide the main circuit board out from the meter. Change jumpers according to the chart below.

**Note:** If a new range is selected, the calibration procedure must also be performed.

Range	J102	J106	JU101	JU102
4-20 mA	D	P	A	No
1-5 V	not field-selectable *			
0-10 V	B	P	V	No

\* Note: Conversion to or from 1-5V must be done at the factory or a Simpson Authorized Service Center.

**Note:** JU101 and JU102 are hard wire jumpers, and are removed by cutting them. Resoldering the JU jumpers is not recommended. If this is required, or if a function is to be changed (from volts to current), Simpson recommends returning the Falcon to the factory or an Authorized Service Center. After moving the jumpers to the desired location, put the Falcon back together and install in your panel, or proceed to calibration.

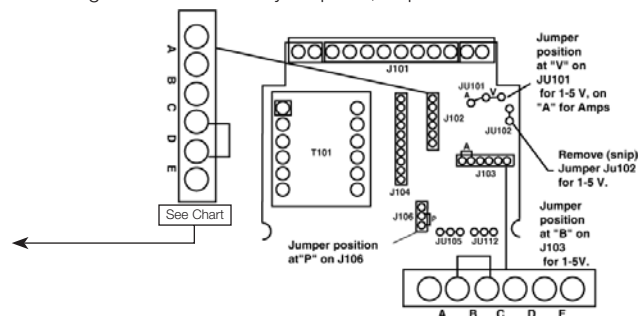

## Display Scaling

The Falcon can be easily scaled to display any engineering unit. For example, if a 4-20mA signal is being monitored, and you want the meter to display 0-100%:

- 1) Remove the front bezel with a small screwdriver.
- 2) Apply a known signal into the meter.
- 3) **Span Adjustment** - Adjust the potentiometer VR101 located on the right side of the display board to the desired scaled value. Maximum value is up to two times, or down to 1/5 the value of the input.
- 4) **Offset Adjustment** - Apply a 4mA signal (1V for 1-5V input, and 0V for 0-10 V input) to terminals #1 and #2, and adjust potentiometer VR102 - located to the left of the display, until the meter displays the desired scaled value. The offset can be scaled up or down a maximum of approximately 250 counts.
- 5) Replace the bezel carefully. A card of labels is provided for alternative engineering units, such as percent.

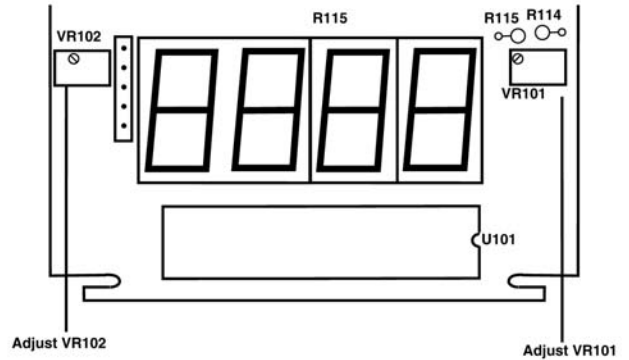

## Calibration

The Falcon is calibrated at the factory per order and scaled to read 0.100.0. If you change the range, and have moved the jumpers, your Falcon will need to be recalibrated.

- 1) Remove the bezel with a small screwdriver.
- 2) Apply the correct minimum value (4mA, 1V or 0V) to the instrument and adjust VR102 (left side of display) until the meter displays or 0.00 (desired minimum display value).
- 3) Apply the maximum input signal to the instrument.
- 4) Adjust the potentiometer (VR101) located on the right side of the display board until the meter displays the value of the input signal or desired maximum display value. For example, if a 20mA signal is applied, adjust the potentiometer until the display indicates 100.0.
- 5) Replace the bezel carefully, and install the meter.

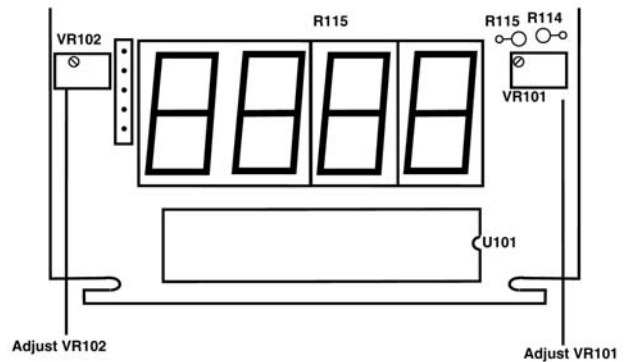

## Excitation Output

An optional feature of the Falcon is the 12VDC or 24VDC Excitation output. The Falcon is set at the factory per your order to include an Excitation plug-in printed circuit board in the range you specify. Excitation supply allows you to power external transmitters and transducers without having to set up additional DC power sources for them.

If your application changes, you can easily change the Excitation value. The Excitation supply can be reconfigured by moving push-on jumper J201 (located on the Excitation board). To change the excitation output value, move the jumper to the correct position shown in the diagram.

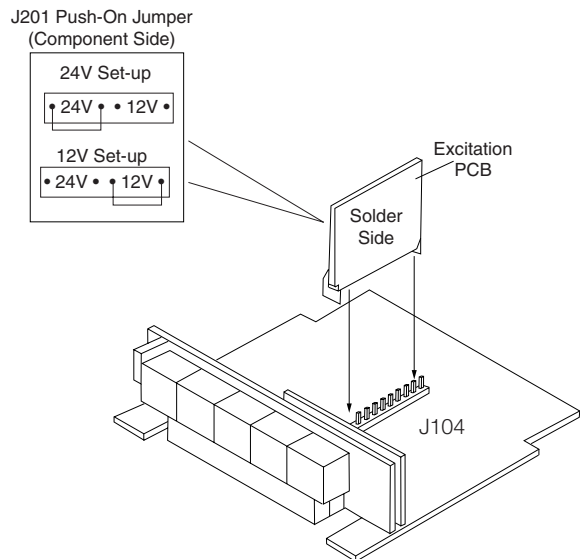

## Application Example

The Quality Assurance department needs to monitor the temperature of a calibration lab. The display needs to be in the hall outside the room so that readings can be checked without having to enter the room.

A Falcon Process meter with a 4-20mA transmitter can handle this application. The Transmitter is designed to take a thermocouple input and emit a 4-20mA signal. By ordering a 0-100°F transmitter with a type T thermocouple, the temperature can easily be measured.

The Falcon meter should be scaled before it is connected to the transmitter. Apply a 4mA signal to the instrument and adjust potentiometer VR102 until the meter displays 0.00 (degrees). Then apply a 20mA signal to the instrument. Adjust potentiometer VR101,

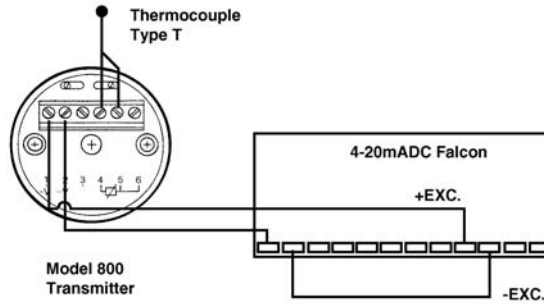

located to the right of the display, until the meter indicates 100.0 (degrees). Carefully put the bezel back on the meter. Remove the signal input. The Falcon has an optional 12 or 24VDC excitation output to power the transmitter, eliminating the need to mount an external DC power source for the transmitter.

The thermocouple is suspended in the room, and connected to the transmitter. The transmitter is attached to the Falcon, and the Falcon is mounted in a box in the hall. The meter will now indicate 0-100°, monitoring the temperature in the calibration lab.

## Ordering Information

Basic Unit	Power Supply	Range	Excitation
F35			
3-1/2 Digit Indicator			
1 120VAC 2 220VAC 3 9-32VDC		71 4-20mA 72 1-5V 73 0-10V	0 None 1 12VDC 2 24VDC

## Safety Symbols



The WARNING sign denotes a hazard. It calls attention to a procedure, practice, or the like, which, if not correctly performed or adhered to, could result in personal injury.



The CAUTION sign denotes a hazard. It calls attention to an operating procedure, practice, or the like, which, if not correctly adhered to, could result in damage to or destruction of part or all the instrument.