



Falcon F45 Series Digital Panel Meter

- **Full 4-1/2 Digit, Bright Red 0.56" (14.2mm) Display**
- **User-Programmable T/C or RTD type (J, K, E, T, R, S, and Platinum 100 RTD)**
- **Jumper-Selectable Display Indicates °C or °F with 0.1° or 1° Display Resolution**
- **Linear mV Scale for Easy Calibration**
- **Short 2.94" (74.7mm) Deep, 1/8 DIN Case**
- **Screw Terminal Connector for Easy Installation**
- **Optional Isolated 9-32VDC Power Supply**



The Falcon Series temperature indicator is a high accuracy, microprocessor-based panel instrument designed to provide the maximum flexibility in temperature measurement. The Falcon automatically compensates for differences between unit temperature (room temperature) and ice point (0°), and provides the complete NIST range for six thermocouple types as well as Platinum 100 RTD. Input ranges are user-

selectable and can be changed without recalibration.

The Falcon series features a standard 1/8 DIN case with a depth of less than 3". Screw terminals are standard for easy installation.

Installation and Panel Cutout

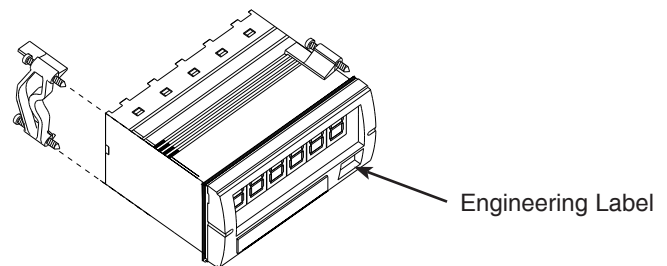
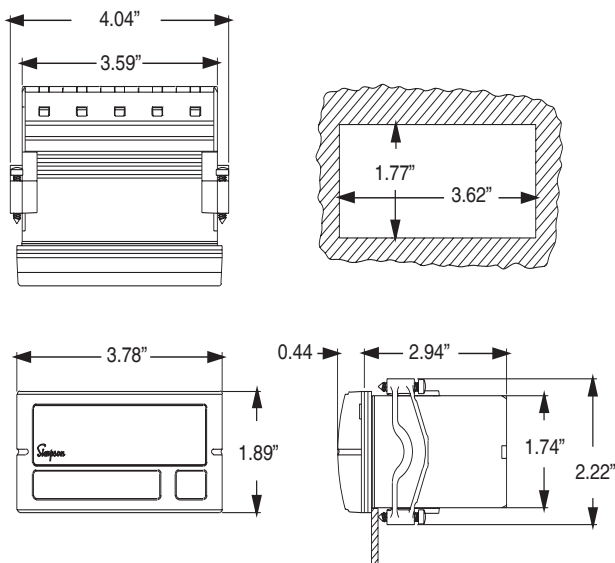

Mounting Requirements

The Falcon series 1/8 DIN indicators require a panel cutout of 1.77" (45mm) high by 3.62" (92mm) wide. To install the Falcon into a panel cutout, remove the clips from the side of the meter. Slide the meter through your panel cutout, then slide the mounting clips back on the meter. Press evenly to ensure a proper fit.

Engineering Label Placement

If replacement of the engineering unit label is required, place the tip of a ball-point pen into the small hole at the base of the engineering label in the bezel. Slide the label up until it pops out. Grasp and remove. Slide the new label half the distance in, then use the ball-point pen to slide it down into place.

Specifications

DISPLAY

Type: 7-segment, red LED
Height: 0.56" (14.2mm)
Decimal Point: Jumper-selectable 2-position (corresponding to resolution desired)
Overrange indication: Most significant digit = "1"; other digits blank
Polarity: Automatic, with "-" indication, "+" indication implied

POWER REQUIREMENTS

AC Voltages: 120 or 220VAC, $\pm 10\%$ 50/60Hz
DC Voltages: 9-32VDC, $\pm 1\%$
Power Consumption: 3VA

ENVIRONMENTAL

Operating Temperature: 0 to 55°C
Storage Temperature: -10 to 60°C
Relative Humidity: 0 to 85% non-condensing
Warm-up Time: Less than 20 minutes

MECHANICAL

Bezel: 3.78" x 1.89" x .44"
 (96 x 48 x 11.2mm)
Depth: 2.94" (74.7mm)
Panel Cut-out: 3.62" X 1.77"
 (91.9 x 45mm 1/8 DIN)
Case Material: 94V-1, UL rated Noryl®
Weight: 9.0oz (255.1g)

INPUTS

Thermocouple: J, K, E, T, R, and S
RTD: Platinum 100
Millivolt: ± 84 mV reading of uncompensated mV
Cold Junction Compensation Error: 0.1°C/°C
Input Impedance: 10M Ω (typical)
Lead Resistance Effect: 4.0 μ V/100 Ω
Conversion Rate: 2-1/2 times per second
Open Thermocouple Detection: -1 on display, -40nA bias on thermocouple

Sensor Type	Temperature Range	Conformance Error	Resolution
E	-200 to 1000°C -328 to 1832°F	$\pm 0.1\%$ of rdg $\pm 0.1^\circ$ C $\pm 0.1\%$ of rdg $\pm 0.2^\circ$ F	0.1° or 1° User-Selectable
J	-200 to 1200°C -328 to 2192°F	$\pm 0.1\%$ of rdg $\pm 0.1^\circ$ C $\pm 0.1\%$ of rdg $\pm 0.2^\circ$ F	0.1° or 1° User-Selectable
K	-200 to 1372°C -328 to 2501°F	$\pm 0.1\%$ of rdg $\pm 0.1^\circ$ C $\pm 0.1\%$ of rdg $\pm 0.2^\circ$ F	0.1° or 1° User-Selectable
T	-200 to 400°C -328 to 752°F	$\pm 0.1\%$ of rdg $\pm 0.1^\circ$ C $\pm 0.1\%$ of rdg $\pm 0.2^\circ$ F	0.1° or 1° User-Selectable
R	-50 to 1768°C -58 to 3214°F	$\pm 0.1\%$ of rdg $\pm 0.2^\circ$ C $\pm 0.1\%$ of rdg $\pm 0.4^\circ$ F	1° Automatic
S	-50 to 1768°C -58 to 3214°F	$\pm 0.1\%$ of rdg $\pm 0.2^\circ$ C $\pm 0.1\%$ of rdg $\pm 0.4^\circ$ F	1° Automatic
mV	-19,999 to +4,000 mV	$\pm 0.02\%$ of rdg* ± 0.002 mV	0.001 or 0.01 mV* User-Selectable
RTD Pt 100	-200 to 850°C -328 to 1562°F	$\pm 0.06\%$ of rdg $\pm 0.1^\circ$ C $\pm 0.06\%$ of rdg $\pm 0.2^\circ$ F	0.1° or 1° User-Selectable

* Usable resolution of 0.002mV. Conformance is to NIST Monograph 175.
 Temperature-Electromotive Force Reference Functions for the Letter-Designated Thermocouple types based on the ITS-90.

Wiring Diagram

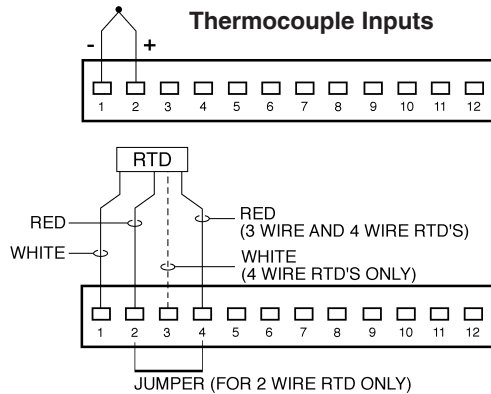

Input Signal: Connect the thermocouple to terminals #1 and #2. RTD inputs are wired per the RTD diagram. See chart below for color codes.

Thermocouple Data

Sensor Type	Connection Information and Lead Color				U.S. ANSI 96.1 Standard Color Code	
	IN- (J101 Pin 1)	IN+ (J101 Pin 2)	RTD- (J101 Pin 3)	RTD+ (J101 Pin 4)	Wire Color Code	Sheath Color Code (1)
E	Red	Purple	N/C	N/C	+Purple -Red	E
J	Red	White	N/C	N/C	+White -Red	J
K	Red	Yellow	N/C	N/C	+Yellow -Red	K
R	Red	Black	N/C	N/C	+Black -Red	R
S	Red	Black	N/C	N/C	+Black -Red	S
T	Red	Blue	N/C	N/C	+Blue -Red	T

(1) Non-Metallic thermocouple sheaths may be a single color, or striped with the second color.

Power Supply Connections

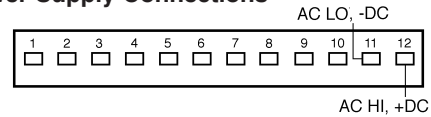

Power Supply: Connect the power supply to terminals #11 and #12. #11 is for AC neutral and -DC, and terminal #12 is for AC Hot and +DC.



- * Before making any electrical connections, make sure all power is off.
- * Do not touch leads, circuit, or the instrument while power is applied.
- * Make sure the hook-up wire is capable of carrying the current required and is well insulated, with no cracks or exposed wiring.



Before switching instrument on, make sure the supply voltage matches the power source required as indicated on model identification label affixed to the top of the meter.

RTD Data

Sensor Type	Connection Information and Lead Color				U.S. ANSI 96.1 Standard Color Code	
	IN- (J101 Pin 1)	IN+ (J101 Pin 2)	RTD- (J101 Pin 3)	RTD+ (J101 Pin 4)	Wire Color Code	Sheath Color Code (1)
2-Wire	White	Red w/jumper to J101 Pin 4	N/C	Jumper to J101 Pin 2	N/A	N/A
3-Wire	White	Red	N/C	Red	N/A	N/A
4-Wire	White	Red	White	Red	N/A	N/A

Function Setup and Range

Thermocouple and RTD selections are made on the main board as shown in the table and diagram to the right.

To gain access to the main board and the display board, the meter must be opened. Use the following procedure:



Disconnect power supply and all connections before opening case.

- 1) Disconnect all wires from terminal block.
- 2) Remove front bezel.
- 3) Slide internal meter out front of unit (it is easier to leave case mounted in the panel).

THERMOCOUPLE OR RTD SELECTION

The thermocouple or RTD selection is made by placing push-on jumpers at the designated positions on the main board. See the table and diagram to the right for location and placement.

EXAMPLE 1: To configure the meter for a J type thermocouple, no jumpers are required on JU6, JU7, JU8, or JU9. A push-on jumper is positioned on JU10 only.

EXAMPLE 2: To configure the meter for a 3-wire RTD, push-on jumpers are positioned on JU9 and JU10 only. No jumpers are required on JU6, JU7, or JU8.

NOTE: Additional jumpers are included for alternate range and scaling selections.

Sensor Type	Jumper Identification				
	JU 6	JU 7	JU 8	JU 9	JU 10
Thermocouple					
J	OUT	OUT	OUT	OUT	IN
K	IN	OUT	OUT	OUT	IN
E	OUT	IN	OUT	OUT	IN
T	OUT	OUT	IN	OUT	IN
R	IN	IN	OUT	OUT	IN
S	IN	OUT	IN	OUT	IN
mV	IN	IN	IN	IN	IN
RTD SENSORS					
2 wire RTD	OUT	OUT	OUT	IN	IN
3 wire RTD	OUT	OUT	OUT	IN	IN
4 wire RTD	OUT	OUT	OUT	IN	OUT

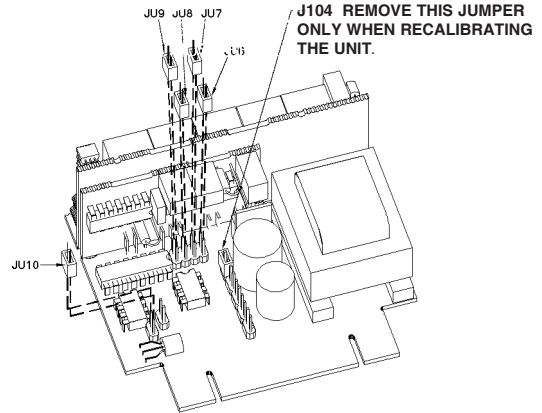

Setup

UNIT MEASUREMENT AND RESOLUTION

These selections are made on the display board, located on the front left side of the display (see diagram). Push-on jumpers (on JU1 and JU2) are used to make your selection. The Fahrenheit / Celsius unit of measurement is selected by using jumper JU2, and the resolution of the meter is determined by using jumper JU1. You can select a resolution of either 0.1° or 1.0° for thermocouple types J, K, T, E or RTD sensors only. Due to inherent characteristics, types R and S must have 1.0° resolution.

Jumper JU1	
°C	N/A
°F	N/A
0.1°	OUT
1°	IN

Jumper JU2	
°C	IN
°F	OUT
0.1°	N/A
1°	N/A

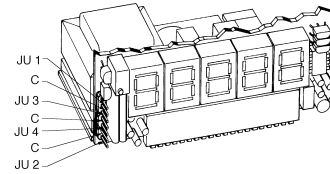

Display Hold

This standard feature allows you to hold the displayed value indefinitely. To activate this feature, create a short circuit across jumpers # 5 and #6 with an ancillary device (such as a switch or computer). To restore the meter to normal display mode, remove the short circuit. This connection must be kept isolated from other circuitry. To hold multiple units, separate poles of the switch must be used to maintain the isolation.



When connecting the ancillary device, ensure that DGND and the ancillary device are at the same potential, or are properly isolated. Failure to do so may result in equipment damage or undesirable ground loops.

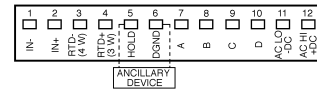

Ordering Information

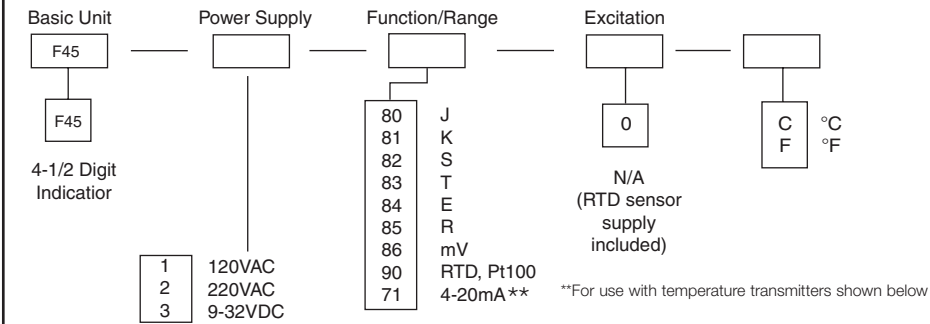

Safety Symbols



The WARNING sign denotes a hazard. It calls attention to a procedure, practice, or the like, which, if not correctly performed or adhered to, could result in personal injury.



The CAUTION sign denotes a hazard. It calls attention to an operating procedure, practice, or the like, which, if not correctly adhered to, could result in damage to or destruction of part or all the instrument.

Accessories

INSULATED THERMOCOUPLES

Soft-wire thermocouples are available in two insulation types. All soft-wire selections have beaded butt welded measurement junctions.

Type	Temperature Rating		Physical Properties		
	Continuous	Single Reading	Abrasion Resistance	Moisture Resistance	Chemical Resistance
Glass Braid	900°F (482°C)	1000°F (*583°C)	Fair	Good	Good
Teflon®	400°F (204°C)	500°F (260°C)	Excellent	Excellent	Excellent

QUICK DISCONNECT ASSEMBLIES

Type	ANSI Color Code	Max. Operating Temperature	Catalog Number
J	Black	1500°F	21238
K	Yellow	1600°F	21239

ORDERING INFORMATION

Cat. No.	Description
THJ105	T/C J, 24 Gauge, Fiber Glass Braid, 5 foot
THJ1015	T/C J, 24 Gauge, Fiber Glass Braid, 15 foot
THK105	T/C K, 24 Gauge, Fiber Glass Braid, 5 foot
THK1015	T/C K, 24 Gauge, Fiber Glass Braid, 15 foot
THJ035	T/C J, 20 Gauge, FEP Teflon®, 5 foot
THJ315	T/C J, 20 Gauge, FEP Teflon®, 15 foot

METAL TRANSITION ASSEMBLIES

Type	ANSI Color Code	Max. Operating Temperature	Catalog Number
J	Black	1500°F	21242
K	Yellow	1600°F	21243
RTD	White	1200°F	21244

Note: A 3/16" compression fitting is available separately for assemblies. Catalog Number 21253.

SPECIFICATIONS

316 Stainless Steel

Best corrosion resistance of the austenitic stainless steel grades. Good corrosion resistance in H₂S. Subject to damaging carbide precipitation. 900 °-1600°F (482°-871°C) range.

Ungrounded Junction

This type of thermocouple junction is fully insulated from the welded sheath end. The ungrounded junction is excellent for applications where stray EMFs would affect the reading and for frequent or rapid temperature cycling. Response time is 2.5 seconds.

Forming

The XACTPAK® sheath can be formed around a mandrel twice the sheath diameter.