



Mini-Max M240 Series Digital Panel Meter

- **Minimum Depth Indicator - Less Than 2.5" (60mm) of Space Required Behind the Panel**
- **Stackable Mounting Bracket Included for Easy Installation**
- **4 Digit, 0.56" (14.2mm) High, Red LED Display**
- **Standard Screw Terminals for Easy Installation**
- **User-Selectable Input Type (J or K T/C, RTD Pt100, mV)**
- **85-250VAC Power Supply**



Simpson's Mini-Max Temperature Indicators provide high quality, accuracy and reliability in a compact case. These microprocessor-based units offer a 0.56" bright red, 4 digit LED display for high visibility. The four input types and choice of °C or °F display are jumper-selectable and can be changed with no recalibration necessary.

A unique mounting bracket is provided to allow for vertical and horizontal stacking of multiple indicators. All Mini-Max units feature a 3/64 DIN, high-impact plastic case. Screw terminals are provided for easy wiring of the power supply and input signal connections.

Installation and Panel Cutout

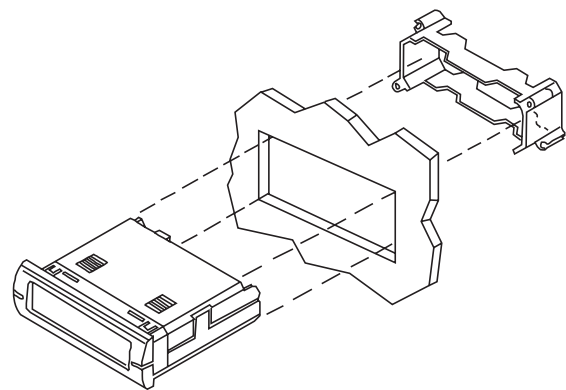
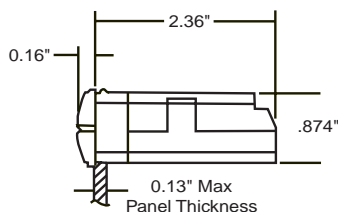
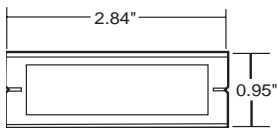
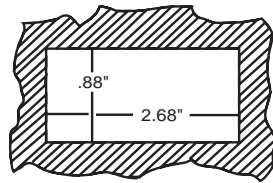
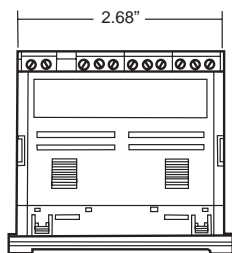

Mounting Requirements

Insert the Mini-Max through the panel, and then slide the mounting bracket on to the Mini-Max. The mounting bracket allows Mini-Max units to be stacked side-to-side or top-to-bottom and maintain the DIN standard panel arrangements in 24mm by 72mm multiples. Panel cutout instructions for stacking multiple units are provided under "stacking features."

Specifications

DISPLAY

Type: 7-segment red LED
Height: 0.56" (14.2mm)

Display resolution: 0.1° from -99.9° to 999.9°; 1.0° below -100° or above 1000°; 0.1mV for mV indication

Overrange indication (T/C or mV): The left-most digit shows 1: "1" (other digits are blank)

Open or faulty input connection: "----"

Uncalibrated instrument:

Display will flash for 2 minutes upon application of power, alternating between "----" and the measured value

Polarity:

Automatic, with "-" indication; "+" indication implied

POWER REQUIREMENTS

AC Voltage: 85-250VAC @50-60Hz
Power Consumption: 2VA

INPUTS

Thermocouple: J, K

Millivolt:

±70mV (uncompensated for temperature)

Lead Resistance Effect: -13µV/100Ω max.

RTD: Platinum 100 Ohm (.00385 alpha)

Lead Resistance Effect:

4-wire: -.26°C/100V max.

2- and 3-wire: 1°C/.29Ω max.

Temperature Coefficient: ±0.1°C / °C

Input Type	Temperature Range	Accuracy @258C
K T/C	-200 to 1370°C	±(0.1% rdg +1°C)
	-328 to 2498°F	±(0.1% rdg +1.8°F)
J T/C	-200 to 1200°C	±(0.1% rdg +1°C)
	-328 to 2192°F	±(0.1% rdg +1.8°F)
RTD Pt100 (4-wire)	-200 to 850°C	±(0.2% rdg +1°C)
	-328 to 1562°F	±(0.2% rdg +1.8°F)
	mV (+0.1mV)	±(0.1% rdg +0.1mV)

Input Impedance: 22MΩ

ENVIRONMENTAL

Operating Temperature: 0 to 55°C

Storage Temperature: -10 to 60°C

Relative Humidity: 0 to 85% non-condensing

Warmup time: Less than 20 minutes

ANALOG TO DIGITAL CONVERSION

Technique: Special dual slope

Rate: 2 samples per second

NOISE REJECTION

NMRR: 60dB, 50/60Hz

MECHANICAL

Bezel: 0.95" x 2.84"
(24mm x 72mm)

Depth: 2.36"(60mm)

Panel cutout: 0.88" x 2.68"
(22.2mm x 68mm)

Weight: 3.5oz (99.2g)

Case Material:

94-0,UL-rated, glass-filled thermoplastic

Wiring Display

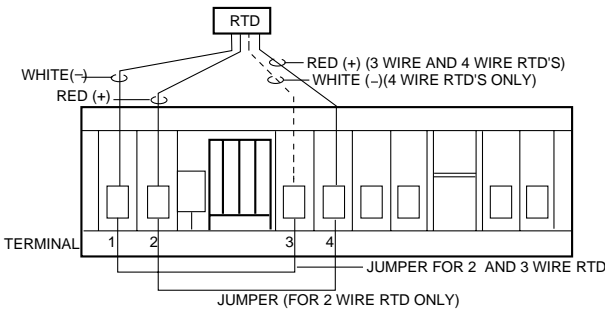
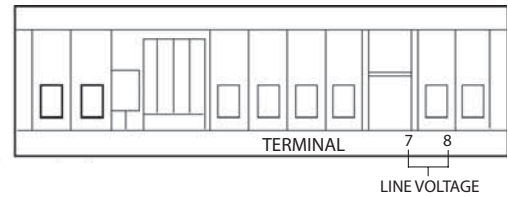
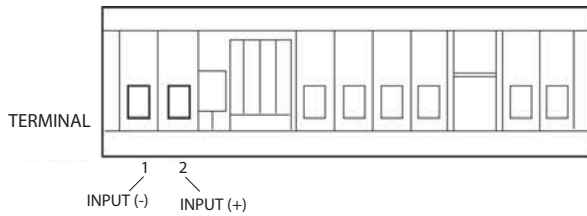

Power Supply: Connect the power supply to terminals #7 and #8 as shown above.



These instruments are designed for maximum safety to the operator when mounted in a panel according to instructions. They are not to be used unmounted or for exploratory measurements in unknown circuits.

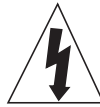

Before switching instrument on, make sure the supply voltage matches the power source required as indicated on the model identification label affixed to the top of the meter.

Input Signal: Thermocouple or mV input is connected to terminals #1 and #2 as shown in the top diagram. RTD input is connected as shown in the RTD diagram.

Input Selection

All Mini-Max Temperature Indicators are configured initially per the customer specifications. Should the application change, the input type can be changed as follows:

Input Type	JU1	JU2	JU3	JU4
J T/C, °C	IN	OUT	OUT	IN
J T/C, °F	IN	IN	OUT	IN
K T/C, °C	IN	OUT	OUT	OUT
K T/C, °F	IN	IN	OUT	OUT
RTD Pt100, °C	OUT	OUT	IN	OUT
RTD Pt100, °F	OUT	IN	IN	OUT
mV	IN	OUT	IN	IN

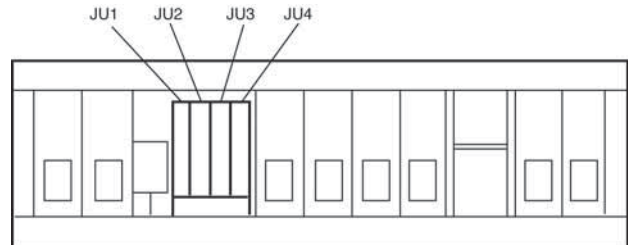

See diagram at right for jumper locations.

NOTE: Recalibration is not required after an input change. If desired, however, procedure is available from Technical Support.

Stacking Features

The mounting brackets, included with every Mini-Max, can be connected together. Multiple units can be mounted in a single opening, allowing perfect alignment.

To punch one hole for multiple units, be sure to adjust the standard panel cutout dimensions as shown here; otherwise the meters will not fit properly in the hole.

Mounting multiple units is quick and easy. Install the first meter (bottom unit first if stacking vertically). Position the next mounting bracket snugly against the first one, and slide the second meter into place. Repeat for remaining units.

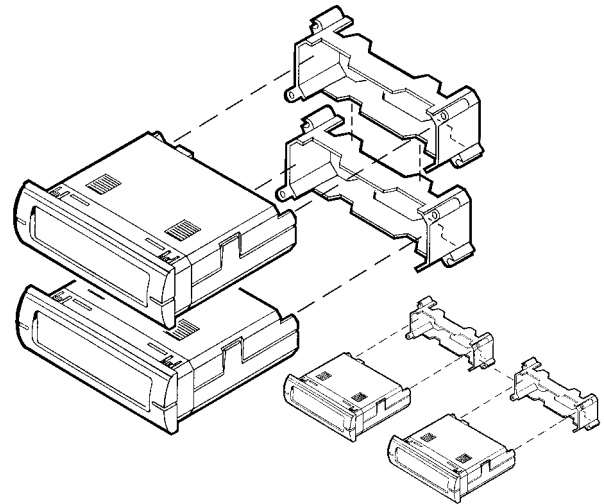

Vertical

Standard cutout

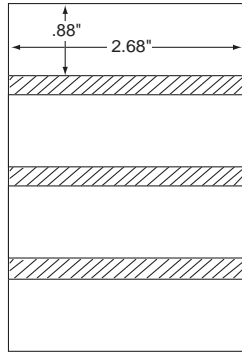

.071"
Add to standard
when stacking

Vertical

Horizontal

Standard cutout



.16"
Add to standard
when stacking

Horizontal

Application Example

A plant engineer wants to install a meter in a panel to measure the temperature of a nearby tank of liquid. The meter must accept a type J thermocouple input and be capable of measuring at least 0-4008F. Depth behind the panel must also be kept to a minimum. A Temperature Mini-Max M240-0-91-0-F will meet the engineer's requirements. Prior to connecting the thermocouple, make sure the jumpers are positioned as follows:

- JU1, JU2, JU4
- JU3

IN
OUT

Connect the wiring according to the diagrams.

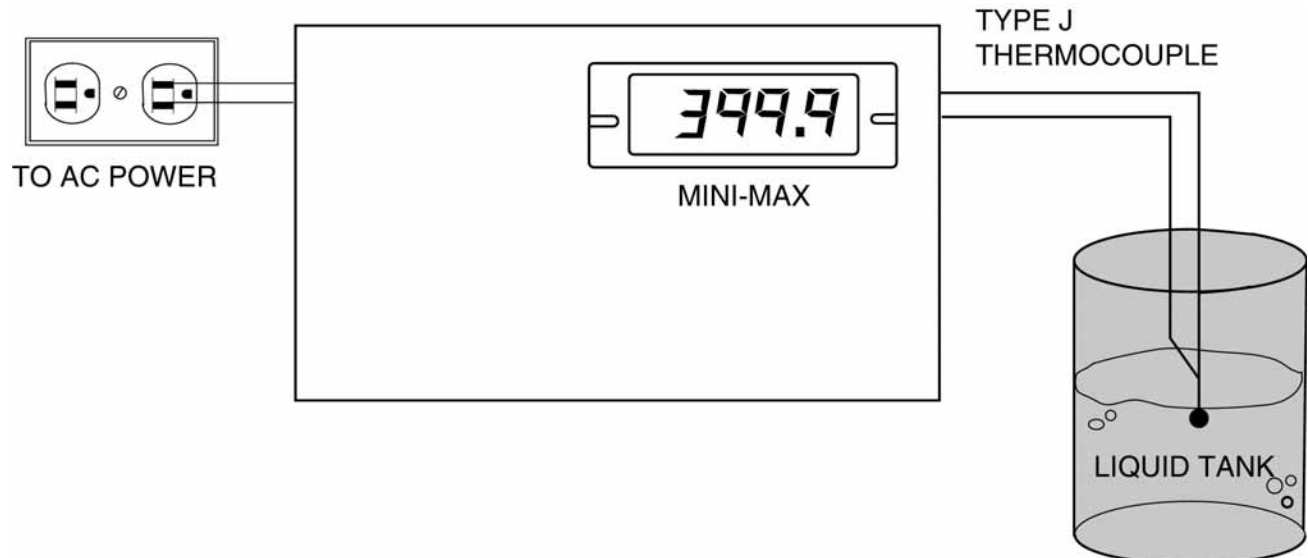

Ordering Information

Your Mini-Max Temperature Indicator can be configured by making an entry for each box.

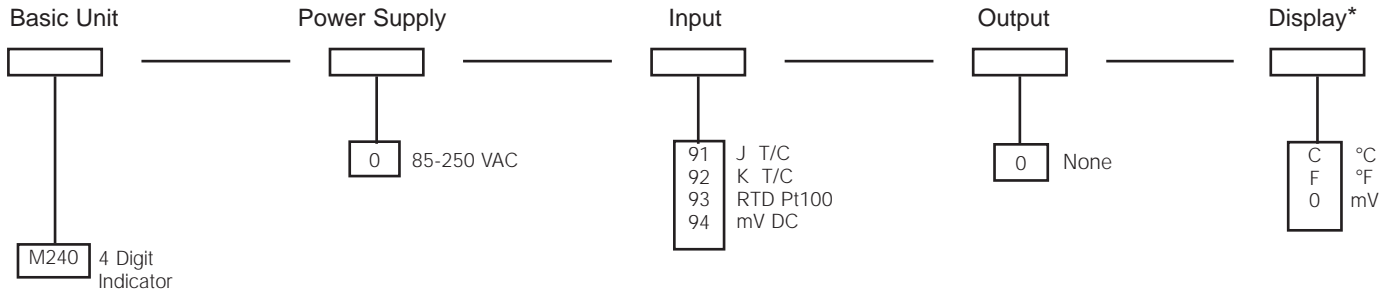

* Choose °C or °F for thermocouple or RTD. mVDC input displays mV reading only, not degrees.

Safety Symbols



The CAUTION sign denotes a hazard. It calls attention to an operating procedure, practice, or the like, which, if not correctly adhered to could result in damage to or destruction of part or all of the instrument.



The WARNING sign denotes a hazard. It calls attention to a procedure, practice, or the like, which, if not correctly performed or adhered to, could result in personal injury.

Accessories

Simpson thermocouples are available in custom lengths per your application. Calibration type, wire gauge, insulation type and length are determined by your specifications, and entered into the following ordering diagram.

Thermocouple Ordering Information (Termination End: HJ-Beaded, CJ-Solid Bare Wire)

THERMOCOUPLE PROBES (QUICK DISCONNECT)

Simpson offers "Quick Disconnect" style thermocouples which include a probe and an ANSI color-coded jack and plug. Each 12-inch thermocouple probe is compacted with MgO insulation, with 316 stainless steel and 0.188 inch diameter outer sheath. Extra plugs and jacks are sold separately. See the table below for ordering information.

THERMOCOUPLE PROBES (48 INCH LEAD WIRE)

Simpson's transition joint thermocouple probes are constructed with MgO insulation. The probe includes 48" of Teflon® coated thermocouple wire and stripped leads.

Thermocouple Ordering Information (Termination End: HJ-Beaded, CJ-Solid Bare Wire)

Cat. No.	Description
THJ105	T/C J, 24 Gauge, Fiber Glass Braid, 5 foot
THJ1015	T/C J, 24 Gauge, Fiber Glass Braid, 15 foot
THK105	T/C K, 24 Gauge, Fiber Glass Braid, 5 foot
THK1015	T/C K, 24 Gauge, Fiber Glass Braid, 15 foot
THJ035	T/C J, 20 Gauge, FEP Teflon®, 5 foot
THJ315	T/C J, 20 Gauge, FEP Teflon®, 15 foot

Type	Catalog Numbers		
	ANSI Color Code	Quick Disconnect	48 Inch Lead Wire
J	Black	21238	21242
K	Yellow	21239	21243
RTD	—	—	21244