



# Mini-Max M245 Series Digital Panel Meter

- **Minimum Depth Indicator - Less Than 2.5" (60mm) of Space Required Behind the Panel**
- **Stackable Mounting Bracket Included for Easy Installation**
- **4-1/2 Digit, 0.5" (12.7mm) High LCD Display with Optional Negative Image, Bright Red Backlighting**
- **Limited Range Display Scaling**
- **Standard Screw Terminals for Easy Installation**
- **Six Current Ranges: 200µA, 2mA, 20mA, 200mA, 2A, 5A**
- **85-250VAC or 9-32VDC Power Supply**



Simpson's Mini-Max Current Indicators provide high quality, accuracy and reliability in a compact, 60mm deep case. Units offer 4-1/2 digit, 0.5" (12.7mm) LCD display and are available with a bright red, negative image backlight option. All units feature user-selectable decimal point, auto zero and limited scaling capabilities.

A unique mounting bracket is provided to allow for vertical or horizontal stacking of multiple indicators. All Mini-Max units feature a 3/64 DIN, high-impact plastic case. The standard units have a clear viewing window, and the units with optional negative image, red backlighting have a red window.

## Installation and Panel Cutout

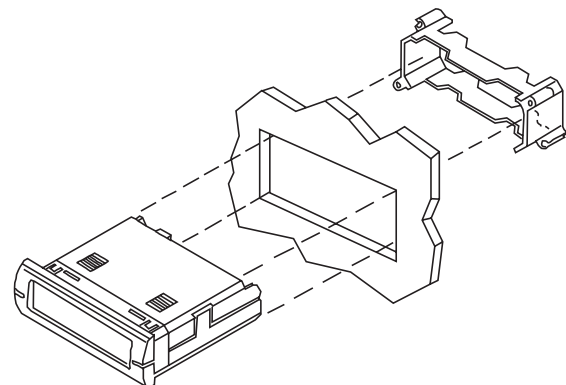
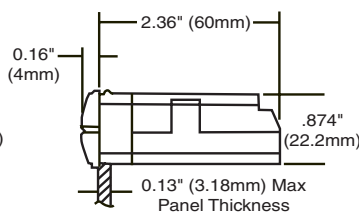
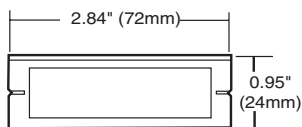
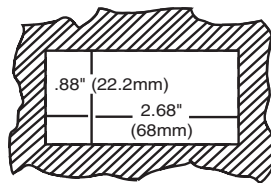
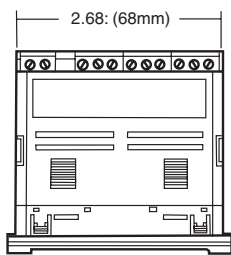

### Mounting Requirements

Insert the Mini-Max through the panel, and then slide the mounting bracket on to the Mini-Max. The mounting bracket allows Mini-Max units to be stacked side-to-side or top-to-bottom and maintain the DIN standard panel arrangements in 24mm by 72mm multiples. Panel cutout instructions for stacking multiple units are provided under "Stacking Features."

# Specifications

## DISPLAY

**Type:** 7-segment LCD

**Height:** 0.5" (12.7mm)

**Decimal point:** 3-position programmable

**Overrange indication:** Most significant digit = "1"

**Backlighting:** Optional negative image, red LED backlighting

**Polarity:** Auto with "-" indication, "+" implied

## POWER REQUIREMENTS

**AC Volt:** 85-250VAC @40-440Hz

**DC Volt:** 9-32VDC

**Power Consumption:**

85-250VAC: 2.5VA min/4VA max

9-32VDC: 1.5VA min/3VA max

**Rated Circuit to Ground Voltage:** 750Vrms

## ACCURACY @ 25°C

$\pm(0.04\%$  of reading + 1 count)

**2A:**  $\pm(0.25\%$  of reading + 1 count)

**5A:**  $\pm(0.5\%$  of reading + 1 count)

## ENVIRONMENTAL

**Operating Temperature:** 0 to 55°C

**Storage Temperature:** -10 to 60°C

**Relative Humidity:** 0 to 85% non condensing @ 40°C

**Temperature Coefficient:**

( $\pm 0.02\%$  of input  $\pm 0.2$  digits) / °C

**Warmup time:** Less than 20 minutes

## NOISE REJECTION

**NMRR:** 60dB, 50/60Hz

**CMRR:** (w/1K $\Omega$  unbalanced @ 60Hz): 90dB min

## ANALOG TO DIGITAL CONVERSION

**Technique:** Integrating

**Rate:** 3 samples/second-typical

## MECHANICAL

**Bezel:** 0.95" x 2.84" (24mm x 72mm)

**Depth:** 2.36" (60mm)

**Panel cutout:** 0.88" x 2.68" (22.2mm x 68mm)

**Weight:** 3.5oz (99.2g)

**Case Material:**

94-0,UL-rated, glass-filled thermoplastic

## INPUTS: DC Current

Range	Resolution	Voltage Drop	Max. Input (unfused)
200 $\mu$ A	10 $\mu$ A	200mV	10mA
2mA	100 $\mu$ A	200mV	40mA
20mA	1 $\mu$ A	200mV	100mA
200mA	10 $\mu$ A	200mV	400mA
2A	100 $\mu$ A	200mV	3A
5A	1mA	50mV	6A

# Wiring Display

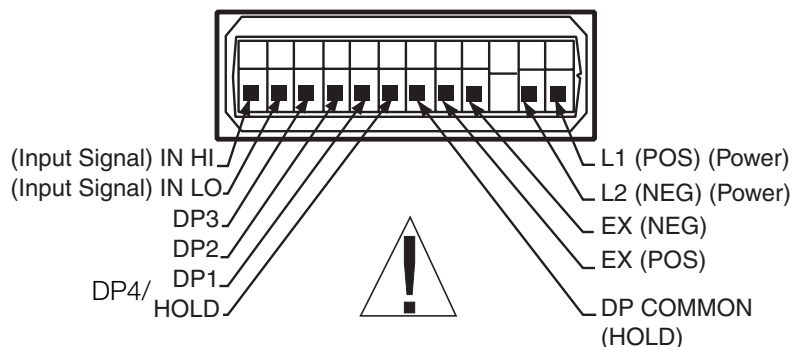

These instruments are designed for maximum safety to the operator when mounted in a panel according to instructions. They are not to be used unmounted or for exploratory measurements in unknown circuits.

**Decimal Point:** To select a decimal point, connect the appropriate DP pin (DP1, DP2, DP3 or DP4) to the DP COMMON (HOLD). Unused DP inputs may remain unconnected (open).

**Display Hold:** Connect HOLD to DP COMMON (HOLD). If this feature is not required, the DP COMMON (HOLD) pin may remain unconnected (open). Hold is optional on this model, and when equipped, replaces DP4. This feature is available from our modification centers.

**Input Signal:** Connect the IN HI and IN LO to the signal to be monitored.

**Input Power:** Connect power to the L1 and L2 terminals. For AC powered units, L1 and L2 are not polarized. **For 9-32 DC powered units, L1 must be positive with respect to L2.**

# Display Scaling

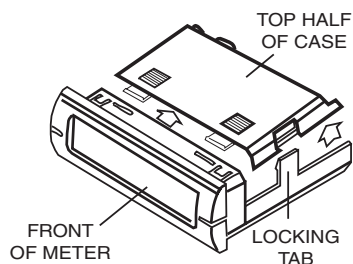

Using a screwdriver or thumbnail, spread tab on each side of case to unlock top half. Lift rear top half and slide away from front of meter.

Mini-Max indicators have limited range coarse and fine adjustments for display scaling. There are no optional connections required for these to function. The "coarse" calibration R12 will allow a limited range of scaling values. The meter can be scaled down to 1/2 the value of the input, but not scaled up. Maximum scaling is maximum input for a maximum reading of 1.9999, which ever is lower. Example: a 2 AMP input has a maximum reading of 1.9999 counts, so you can't double the 2 AMP's, but you can make 1 AMP read 1.9999. the "fine" calibration R9 allows for an approximate range of 1% of the "coarse" calibration. Apply full scale input to the meter. Adjust R12 to be within 1% of the desired scaled value, then use R9 to obtain the final desired result.

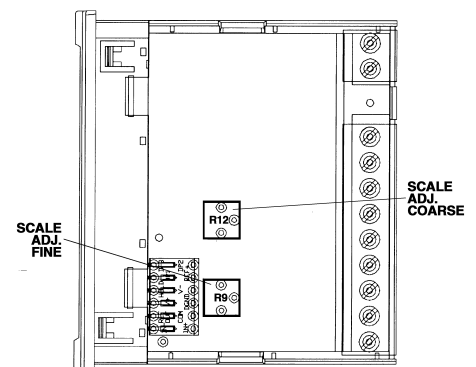

**Note:** Any physical damage to the meter during calibration will void the warranty

## Stacking Features

The mounting brackets, included with every Mini-Max, can be connected together. Multiple units can be mounted in a single opening, allowing perfect alignment.

To punch one hole for multiple units, be sure to adjust the standard panel cutout dimensions as shown here; otherwise the meters will not fit properly in the hole.

Mounting multiple units is quick and easy. Install the first meter (bottom unit first if stacking vertically). Position the next mounting bracket snugly against the first one, and slide the second meter into place. Repeat for remaining units.

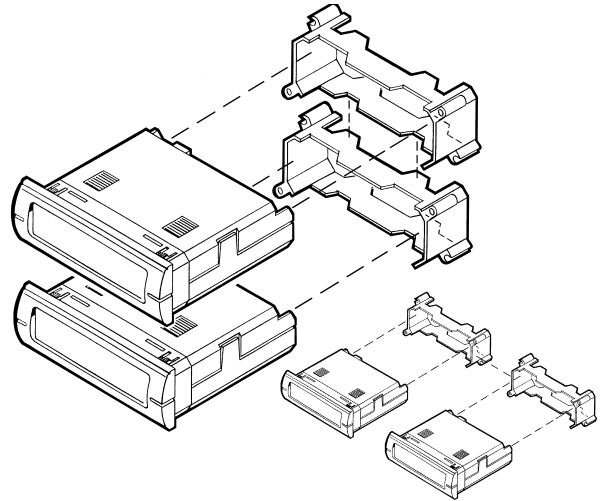

### Vertical

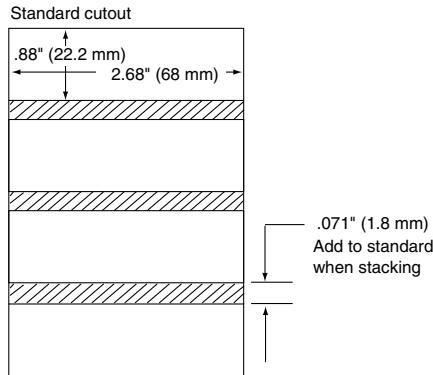

### Vertical

### Horizontal

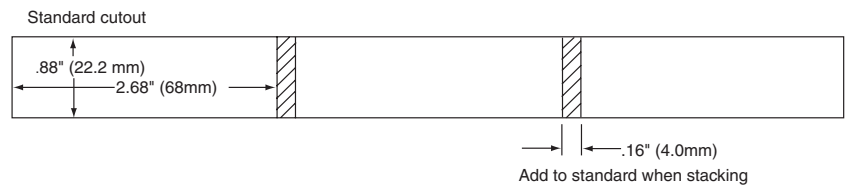

### Horizontal

## Backlight Option and Decimal Point Selection

Negative image, bright red backlighting is available in the Mini-Max. This illumination allows the unit to be read in low light areas. Backlighting power is supplied by the Mini-Max, so no additional external power is required.

Decimal point selection is accomplished by connecting the appropriate DP terminal to the DP Common terminal.

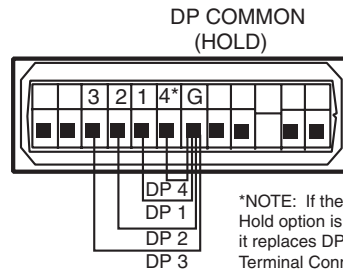

\*NOTE: If the Display Hold option is ordered, it replaces DP4 on the Terminal Connector.

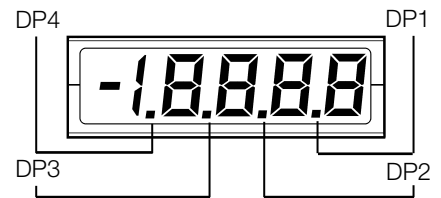

## Excitation Output

Excitation output is available in the Mini-Max for powering external transmitters or transducers. Excitation is available from the EX POS and EX NEG terminals. This source is isolated from the measurement input as well as the input power circuits. The voltages available are 12VDC or 24VDC, with a maximum load current of 25 milliamps. This feature eliminates the need to mount an external DC power source for transducers or sensors used in your application.

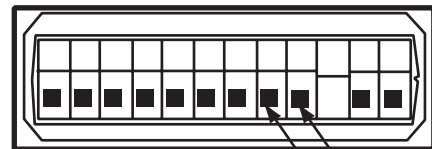

EX NEG  
EX POS



Do not exceed an excitation load current of 25mA!

# Application Example

A company needs to monitor the power supply voltage and load current of a 12VDC motor.

**Voltage:** A Mini-Max DC Volt meter, configured for the 20 volt range, is installed in parallel with the power source. The IN HI is connected to the positive lead of the power supply. The IN LO is connected to the negative lead of the power supply.

**Current:** A second Mini-Max DC Volt meter, configured for the 200 millivolt range, is used with a 100A/50mV shunt (sold separately) to measure the load current. The meter is first scaled to read 100.0 at 50mV by applying a 50mV input to the meter and adjusting R9 and R12 until the display reads 100.0. The meter is connected to the shunt, and the shunt is installed in series on the negative leg of the power supply. The positive lead of the shunt is connected to the IN HI terminal,

and the negative lead connected to the IN LO terminal. The Mini-Max units will indicate the power supply voltage and load current of the motor.

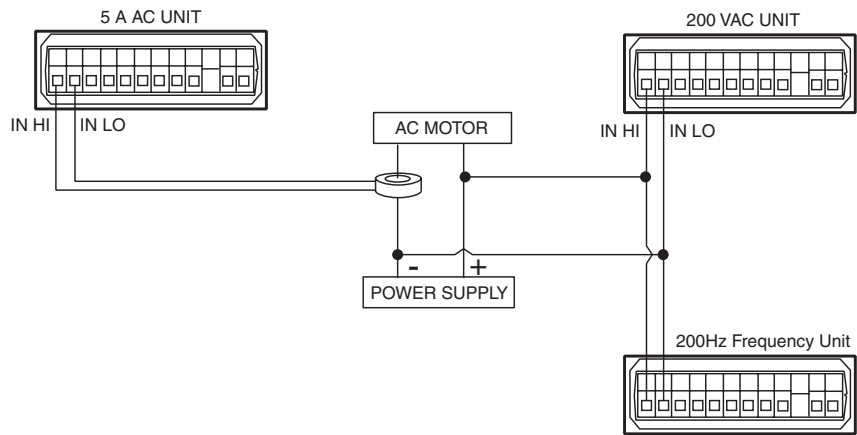

# Ordering Information

The Mini Max Voltage Indicator can be configured by making an entry for each box

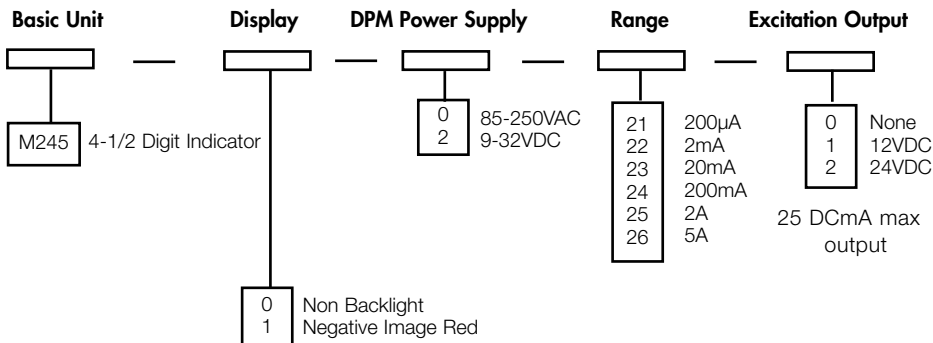

**NOTE:** Display hold feature is configured at the factory only. Must specify at time of order.

**Note:** Special scaling is available from the factory at the time of ordering.

# Safety Symbols



The WARNING sign denotes a hazard. It calls attention to a procedure, practice, or the like, which, if not correctly performed or adhered to, could result in personal injury.



The CAUTION sign denotes a hazard. It calls attention to an operating procedure, practice, or the like, which, if not correctly adhered to, could result in damage to or destruction of part or all of the instrument.

# Accessories

## Portable

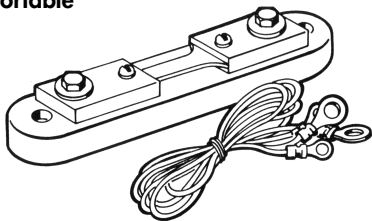

External shunts enable digital panel meters to indicate higher currents than can be provided with self-contained internal shunt meters. The shunt is installed in series with the load and source. The shunts produce a DCmV drop which is sent to the display unit. The Mini-Max can be scaled to display the actual current between the load and the source. Simpson manufactures portable and switchboard shunts.

Each shunt includes 5' leads.

## Switchboard

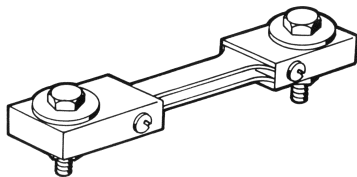

# Ordering Information

## Portable Shunts 50mV

Amps	Cat. Number
1	06700
5	06703
10	06704
15	06705
25	06707
30	06708
50	06709
75	06711
100	06713
150	06714
200	06715

## Switchboard Shunts 50mV

Amps	Cat. Number
100	06500
150	06503
200	06504
250	06505
300	06506
400	06507
500	06508