

To prevent accidents arising from the misuse of this controller, please ensure the operator using it receives this manual.

**Warning**

Turn the power supply to the instrument off before wiring or checking.  
Working or touching the terminal with the power switched on may result in severe injury or death due to Electric Shock.

**1. System configuration**

RS-485 multi-drop connection communication (Option: C5)

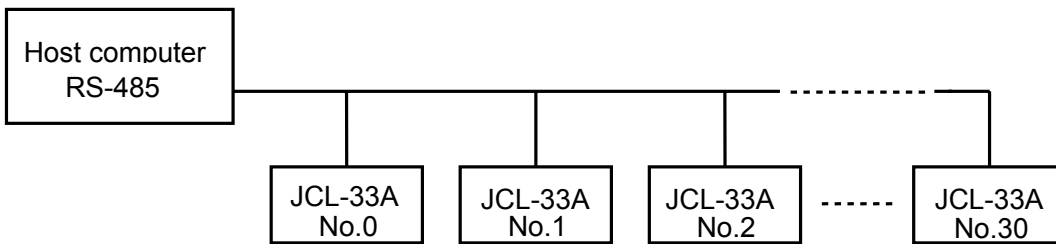

(Fig. 1-1)

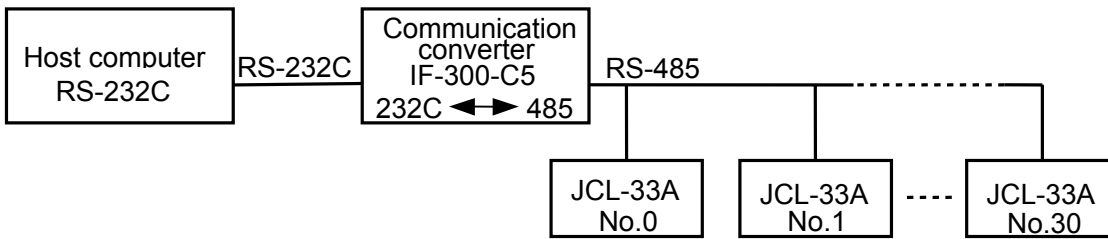

(Fig. 1-2)

**Note: Communication converter IF-300-C5 (sold separately) is only available for Shinko protocol.  
For the Modbus protocol, use a commercially available communication converter.**

Setting value digital transmission application example

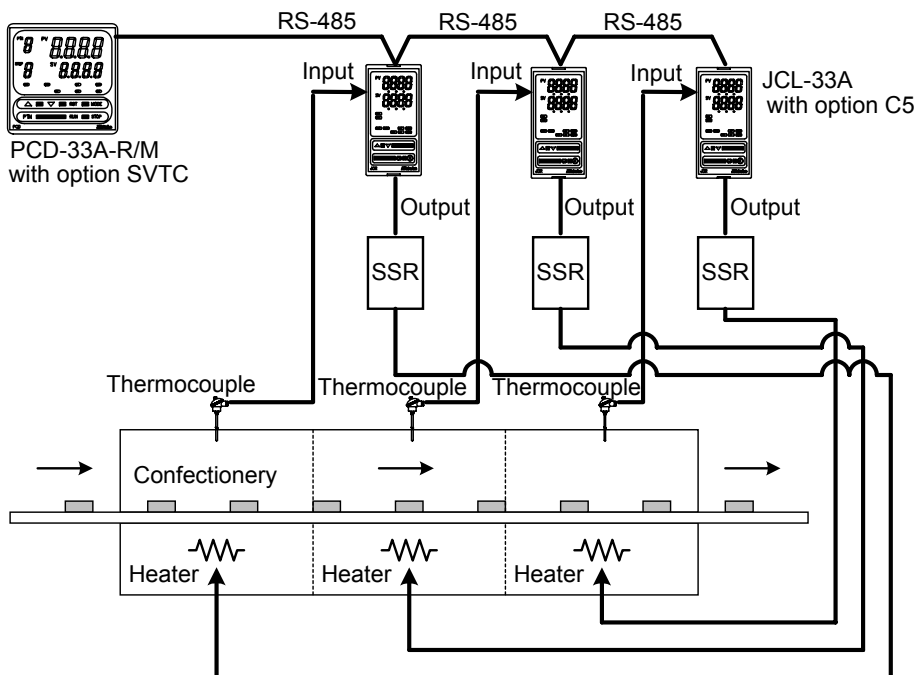

(Fig. 1-3)

## 2. Wiring connection

### Serial communication (option C5)

#### When using communication converter IF-300-C5

- Connector: D sub 25-pin

Connection: RS-232C ↔ RS-485 (Communication speed: 2400, 4800, 9600, 19200bps)

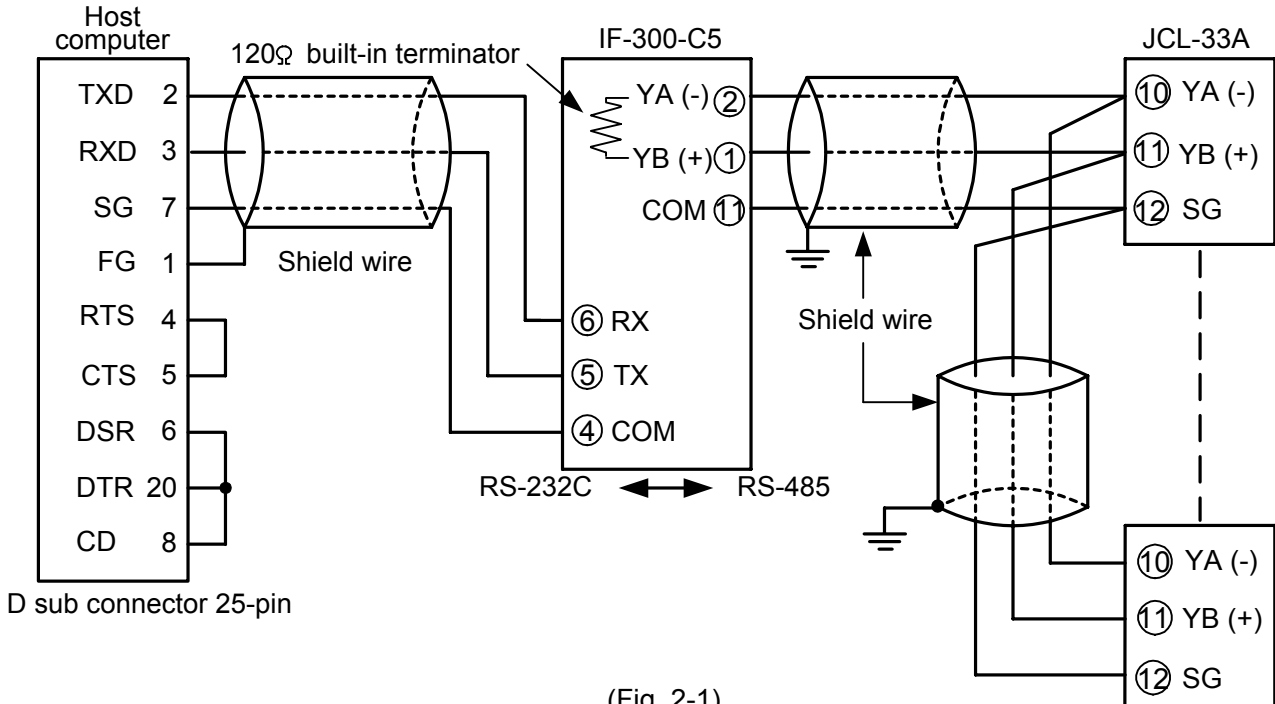

- Connector: D sub 9-pin

Connection: RS-232C ↔ RS-485 (Communication speed: 2400, 4800, 9600, 19200bps)

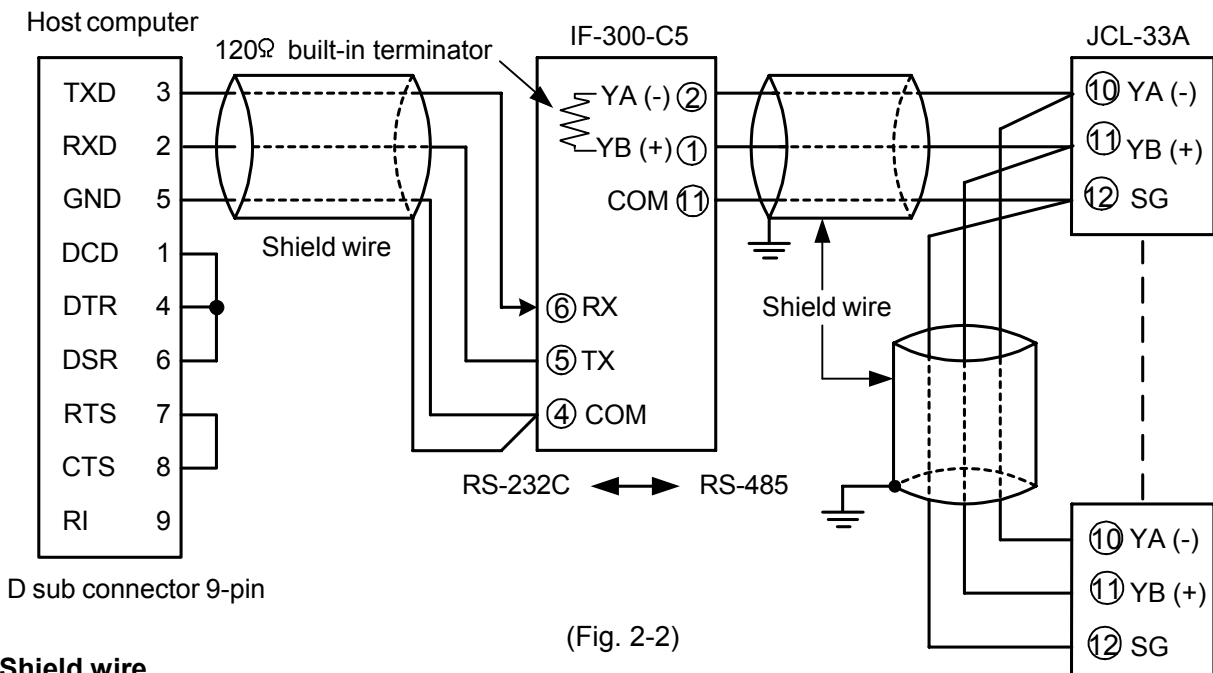

#### Shield wire

Connect only one side of the shield wire to the FG or GND terminal so that current cannot flow to the shield wire.

(If both sides of the shield wire are connected to the FG or GND terminal, the circuit will be closed between the shield wire and the ground. As a result, current will run through the shield wire and this may cause noise.)

Never fail to ground FG and GND terminals.

#### Terminator (Terminal resistor)

Communication converter IF-300-C5 (sold separately) has a built-in terminator.

The terminator is mounted at the end of the wire when connecting a personal computer with multiple peripheral devices. The terminator prevents signal reflection and disturbance.

Do not connect a terminator with the communication line because the JCL-33A has built-in pull-up and pull-down resistors instead of a terminator.

### Setting value digital transmission

With the wiring of the Setting value digital transmission, connect YA (-) with YA (-), YB (+) with YB (+) and COM with COM respectively.

A maximum of 31 units of the JCL-33A can be connected.

The following shows an example of connection when using setting value digital transmission function between the PCD-33A and JCL-33A

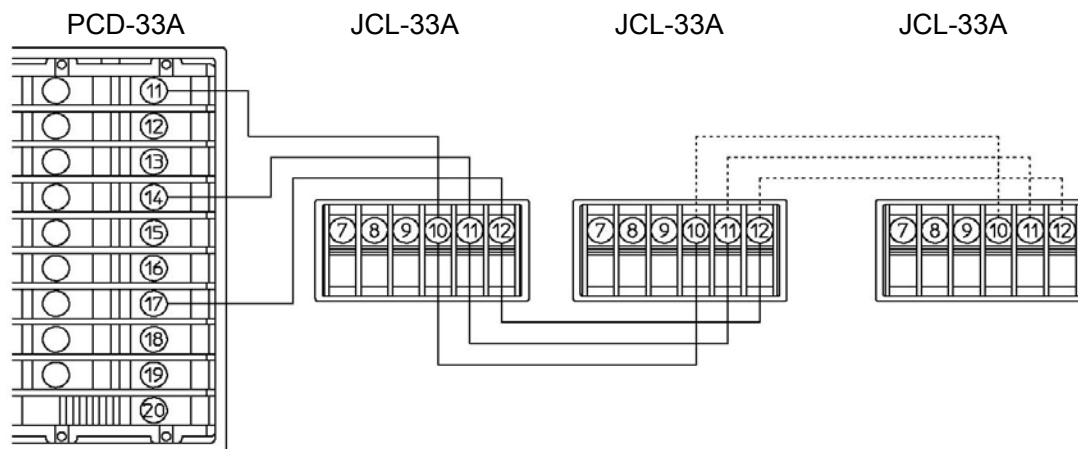

(Fig. 2-3)

## 3. Setup of the JCL-33A

### • Serial communication (option C5)

It is necessary to set an instrument number to each of the JCL-33A units individually when communicating by connecting plural units.

Select a communication speed for the JCL-33A according to that of the host computer.

### • Setting value digital transmission

When Setting value digital transmission and Setting value digital reception are used, select a communication protocol as follows.

#### Procedure for Setting value digital transmission between PCD-33A and JCL-33A

##### (1) Setting to PCD-33A

If the option SVTC is applied, it is not necessary to set any item.

Check if Setting value digital transmission [] is selected during Communication protocol selection [] in Auxiliary function setting mode 1.

##### (2) Setting to JCL-33A

Check if the communication speed in Auxiliary function setting mode 1 of the JCL-33A is identical with that of PCD-33A.

##### (3) Setting value digital transmission starts.

Input program setting value to the PCD-33A.

If the program is initiated by pressing the RUN key, PCD-33A setting values are transmitted to the JCL-33A.

During program standby mode, "0" is sent to the JCL-33A.

- For the Communication protocol and Communication speed selection, refer to the Instruction manual for the JCL-33A.

## 4. Communication procedure

Communication starts with command transmission from the host computer (hereafter Master) and ends with the response of the JCL-33A (hereafter Slave).

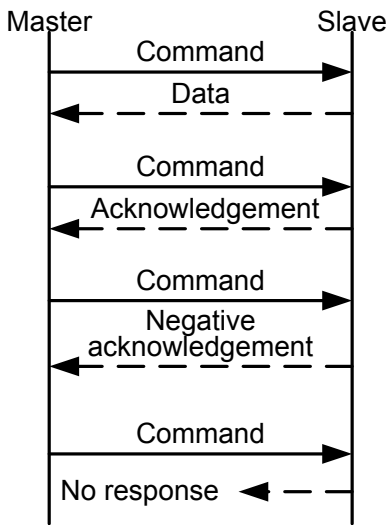

(Fig.4-1)

- **Response with data**

When the master sends the reading command, the slave responds with the corresponding setting value or current status.

- **Acknowledgement**

When the master sends the setting command, the slave responds by sending a acknowledgement after the processing is terminated.

- **Negative acknowledgement**

When the master sends non-existent command or a value outside the setting range, the slave returns a negative acknowledgement.

- **No response**

The slave will not respond to the master when global address is set, or when there is a framing error or checksum error (for Shinko protocol), or when LRC discrepancy (for Modbus protocol ASCII mode) or CRC discrepancy (for Modbus protocol RTU mode) is detected.

### Communication timing of the RS-485 (option C5)

#### Slave side

When the slave starts transmission to RS-485 communication line, the slave is arranged so as to provide an idle status (mark status) **transmission period of 1 or more characters** before sending the response to ensure the synchronization on the receiving side.

The slave is arranged so as to disconnect the transmitter from the communication line **within a 1 character transmission period** after sending the response.

#### Master side (Notice on programming)

Set the program so that the master can disconnect the transmitter from the communication line **within a 1 character transmission period** after sending the command in preparation for reception of the response from the slave.

To avoid the collision of transmissions between the master and the slave, send the next command after carefully checking that the master received the response.

#### Note:

**When the master communicates with the slave through the communication converter (IF-300-C5), it is not required to manage the transmission timing described above, because the converter automatically sets the transmission timing interpreting the protocol.**

## 5. Shinko protocol

### 5.1 Transmission mode

Shinko protocol is composed of ASCII codes.

Hexadecimal (0 to 9, A to F), which is divided into high order (4-bit) and low order (4-bit) out of 8-bit binary data in command is transmitted as ASCII characters.

Data format

Start bit	: 1 bit
Data bit	: 7 bits
Parity	: Even
Stop bit	: 1 bit
Error detection:	Checksum

### 5.2 Command configuration

All commands are composed of ASCII. The data (setting value, decimal number) is represented by hexadecimal figures, and ASCII code is used.

The negative numbers are represented by 2's complement.

#### (1) Setting command

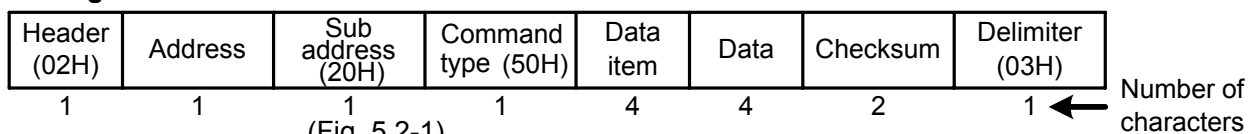

## (2) Reading command

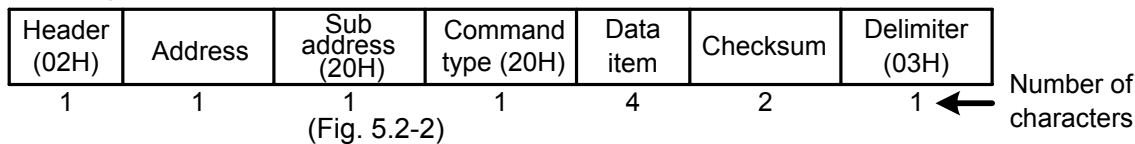

## (3) Response with data

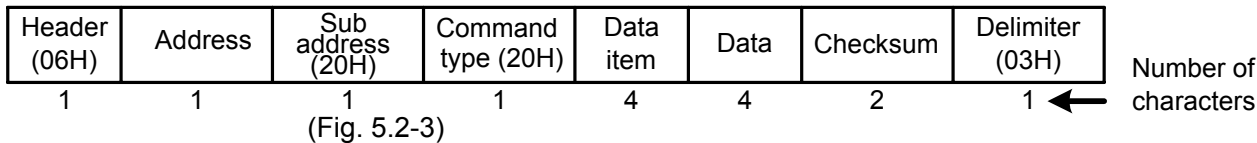

## (4) Acknowledgement

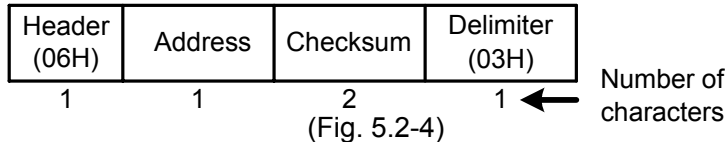

## (5) Negative acknowledgement

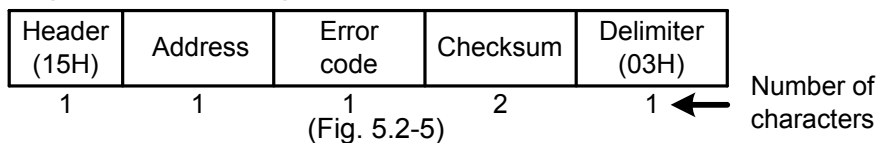

**Header** : Control code to represent the beginning of the command or the response  
ASCII codes are used.

Setting command, Reading command : STX(02H) fixed

Response with data, Acknowledgement: ACK(06H) fixed

Negative acknowledgement : NAK(15H) fixed

**Address** : Numbers by which the master discerns each slave.

Instrument number 0 to 94 (00H to 5EH) and Global address 95 (5FH)

The numbers (20H to 7EH) are used by giving 20H of bias.

95 (7FH) is called Global address, which is used when the same command is sent to all the slaves connected. However, a response is not returned.

**Sub address** : (20H) fixed

**Command type** : Code to discern Setting command (50H) and Reading command (20H)

**Data item** : Data classification of the command object

Composed of hexadecimal 4 digits (Refer to the Communication command table)

**Data** : The contents of data (setting value) differs depending on the setting command.

Composed of hexadecimal 4 digits (Refer to the Communication command table)

**Checksum** : 2-character data to detect communication errors

**Delimiter** : Control code to represent the end of command  
(03H) fixed

**Error code** : Represents an error type. Composed of hexadecimal 1 digit.

1 (31H)----Non-existent command

2 (32H)----Not used

3 (33H)----Setting value outside the setting range

4 (34H)----Unsettable status (e.g. AT is performing)

5 (35H)----During setting mode by keypad

## 5.3 Checksum calculation

Checksum is used to detect receiving errors in the command or data.

Set the program for the master side as well to calculate the checksum of the response data from the slaves so that the communication errors can be checked.

The ASCII code (hexadecimal) corresponding to the characters which range from the address to that before the checksum is converted to binary notation, and the total value is calculated.

The lower 2-digits of the total value are converted to 2's complements and then to hexadecimal figures, that is, ASCII code for the checksum.

### Checksum calculation example

Step 1, step SV: 600°C (0258H)

Address (instrument number): 0 (20H)

- 1's complement: Reverse each binary bit. 0 will become 1 and vice versa.

- 2's complement: Add 1 to 1's complement.

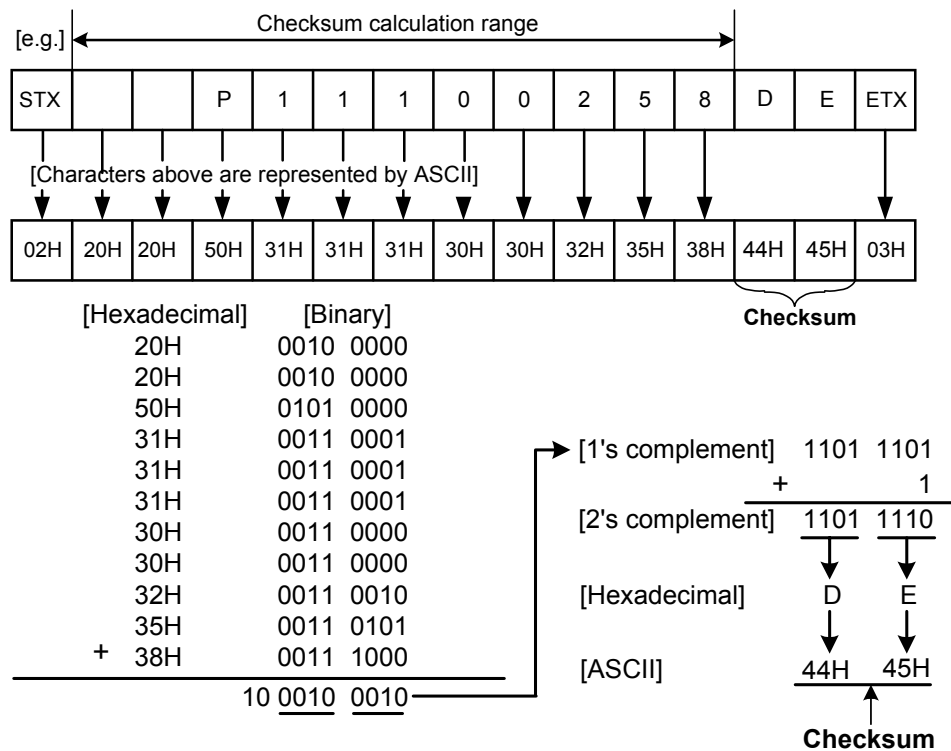

## 5.4 Contents of the command

### Notes on the setting command and reading command

- It is possible to set the setting value by setting command of the communication function even if the setting value is locked.
- Although the options are not applied, setting the optional items is possible by the setting command. However, they will not function.
- The memory can store up to 1,000,000 (one million) entries.  
If the number of setting times exceeds the limit, it cannot memorize the data. So frequent transmission via communication is not recommended.
- When connecting plural slaves, the address (instrument number) must not be duplicated.
- When sending a command by Global address [95 (7FH)], the same command is sent to all the slaves connected. However, the response is not returned.
- The instrument number and communication speed of the slave cannot be set by communication.

### Setting command

- The settable range is the same as the one by keypad.  
For communication command, refer to the communication command table of this manual.
- All commands are composed of ASCII.
- The data (setting value, decimal) is converted to hexadecimal figures, and ASCII is used.  
Negative numbers are represented by 2's complement. When the data (setting value) has a decimal point, the whole number without a decimal point is used.

### Reading command

- All commands are composed of ASCII.
- The data (setting value, decimal) is converted to hexadecimal figures, and ASCII is used.  
Negative numbers are represented by 2's complement. When the data (setting value) has a decimal point, the response is returned as a whole number without a decimal point.

## 5.5 Command example

### (1) Reading (Address 1, PV)

- Reading command from the master

Header (02H)	Address (21H)	Sub address (20H)	Command type (20H)	Data item (30H 30H 38H 30H)	Checksum (44H 37H)	Delimiter (03H)
1	1	1	1	4	2	1

(Fig. 5.5-1)

Number of characters

- Response from the slave in normal status [When PV=25°C (0019H)]

Header (06H)	Address (21H)	Sub address (20H)	Command type (20H)	Data item (30H 30H 38H 30H)	Data (30H 30H 31H 39H)	Checksum (30H 44H)	Delimiter (03H)
1	1	1	1	4	4	2	1

(Fig. 5.5-2)

Number of characters

**(2) Reading (Address 1, SV1)**

- Reading command from the master

Header (02H)	Address (21H)	Sub address (20H)	Command type (20H)	Data item (30H 30H 30H 31H)	Checksum (44H 45H)	Delimiter (03H)
1	1	1	1	4	2	1

(Fig. 5.5-3)

Number of characters

- Response from the slave in normal status [When SV1=100°C (0064H)]

Header (06H)	Address (21H)	Sub address (20H)	Command type (20H)	Data item (30H 30H 30H 31H)	Data (30H 30H 36H 34H)	Checksum (31H 34H)	Delimiter (03H)
1	1	1	1	4	4	2	1

(Fig. 5.5-4)

Number of characters

**(3) Setting (Address 1, SV1) [When SV1 is set to 100°C(0064H)]**

- Setting command from the master

Header (02H)	Address (21H)	Sub address (20H)	Command type (50H)	Data item (30H 30H 30H 31H)	Data (30H 30H 36H 34H)	Checksum (45H 34H)	Delimiter (03H)
1	1	1	1	4	4	2	1

(Fig. 5.5-5)

Number of characters

- Response from the slave in normal status

Header (06H)	Address (21H)	Checksum (44H 46H)	Delimiter (03H)
1	1	2	1

(Fig. 5.5-6)

**6. Modbus protocol**

**6.1 Transmission mode**

There are 2 transmission modes (ASCII and RTU) in Modbus protocol.

**6.2 ASCII mode**

Hexadecimal (0 to 9, A to F), which is divided into high order (4-bit) and low order (4-bit) out of 8-bit binary data in the command is transmitted as ASCII characters.

- Data format
- Start bit : 1 bit
- Data bit : 7 bits
- Parity : Even
- Stop bit : 1 bit
- Error detection: LRC (Longitudinal Redundancy Check)
- Data interval : 1 second or less

**(1) Message configuration**

ASCII mode message is configured to start by [: (colon)(3AH)] and end by [CR (carriage return) (0DH) + LF (Line feed)(0AH)]. (See Fig. 6.2-1)

Header (:)	Slave address	Function code	Data	Error check LRC	Delimiter (CR)	Delimiter (LF)
---------------	------------------	------------------	------	--------------------	-------------------	-------------------

(Fig. 6.2-1)

**Slave address**

Slave address is an individual instrument number on the slave side and is set within the range 00H to 5FH (0 to 95).

The master identifies slaves by the slave address of the requested message.

The slave informs the master which slave is responding to the master by placing its own address in the response message.

[Slave address 00H (broadcast address) can identify all the slaves. However slaves do not respond.]

## Function code

The function code is the command code that makes the slave to undertake the following action types (Table 6.2-1).

(Table 6.2-1)

Function code	Contents
03 (03H)	Reading the setting value and information from slaves
06 (06H)	Setting to slaves

A function code is used to discern whether the response is normal (acknowledgement) or if any error (negative acknowledgement) has occurred when the slave returns the response message to the master. When acknowledgement is returned, the slave simply returns the original function code. When negative acknowledgement is returned, the MSB of the original function code is set as 1 for the response.

(For example, when the master sends a request message setting 10H to function code by mistake, slave returns 90H by setting the MSB to 1, because the former is an illegal function.)

For negative acknowledgement, abnormal code (Table 6.2-2) below is set to the data of response message and returned to the master in order to inform it that what kind of error has occurred.

(Table 6.2-2)

Abnormal code	Contents
1 (01H)	Illegal function (Non-existent function)
2 (02H)	Illegal data address (Non-existent data address)
3 (03H)	Illegal data value (Value outside the setting range)
17 (11H)	Illegal setting (Unsettable status)
18 (12H)	Illegal setting (During setting mode by keypad, etc)

## Data

Data differs depending on the function code.

A request message from the master is composed of data item, number of data and setting data.

A response message from the slave is composed of number of bytes, data and abnormal code in negative acknowledgement. Only one piece of data can be dealt with per message.

Therefore the number of data for ASCII mode is fixed as (30H 30H 30H 31H).

Effective range of data is -32768 to 32767 (8000H to 7FFFH).

### (2) ASCII mode error check

After calculating LRC (Longitudinal Redundancy Check) from the slave address to the end of data, the calculated 8-bit data is converted to two ASCII characters and are appended to the end of the message.

#### How LRC is calculated

- ① Create a message in RTU mode.
- ② Add all the values from the slave address to the end of data. This is assumed as X.
- ③ Make a complement for X (bit reverse). This is assumed as X.
- ④ Add a value of 1 to X. This is assumed as X.
- ⑤ Set X as an LRC to the end of the message.
- ⑥ Convert the whole message to ASCII characters.

### (3) ASCII mode message example

#### ① Reading (Address 1, SV1)

- A request message from the master

The number of data indicates the data item to be read and it is fixed as (30H 30H 30H 31H).

Header (3AH)	Slave address (30H 31H)	Function code (30H 33H)	Data item (30H 30H 30H 31H)	Number of data (30H 30H 30H 31H)	Error check LRC (46H 41H)	Delimiter (0DH 0AH)	Number of characters ←
1	2	2	4	4	2	2	

(Fig. 6.2-2)

- A response message from the slave in normal status [When SV1=100°C (0064H)]

The number of response bytes indicates the number of bytes of the data which has been read, and it is fixed as (30H 32H).

Header (3AH)	Slave address (30H 31H)	Function code (30H 33H)	Number of response bytes (30H 32H)	Data (30H 30H 36H 34H)	Error check LRC (39H 36H)	Delimiter (0DH 0AH)	Number of characters ←
1	2	2	2	4	2	2	

(Fig.6.2-3)

- A response message from the slave in abnormal status (When data item is mistaken)  
The function code MSB is set to 1 for the response message in abnormal status.  
(Value: 83H, ASCII: 38H 33H).

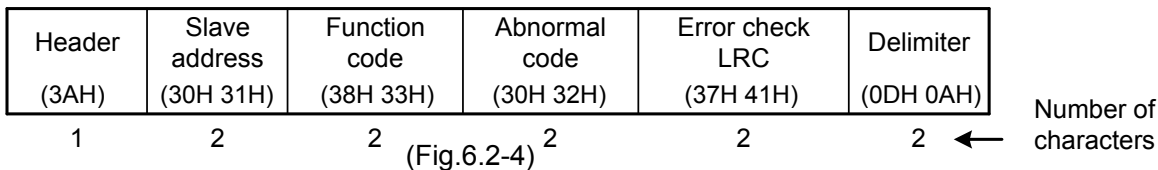

### ② Reading (Address 1, SV1)

- Request message from the master  
The number of the data indicates the data item to be read and it is fixed as (30H 30H 30H 31H).

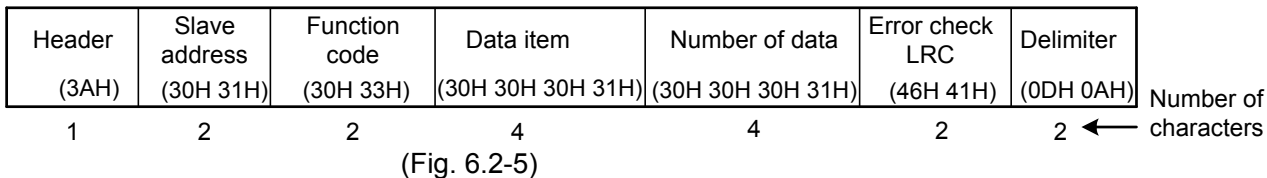

- A response message from the slave in normal status [When SV1=100°C (0064H)]  
The number of response bytes indicates the number of bytes of the data which has been read, and it is fixed as (30H 32H).

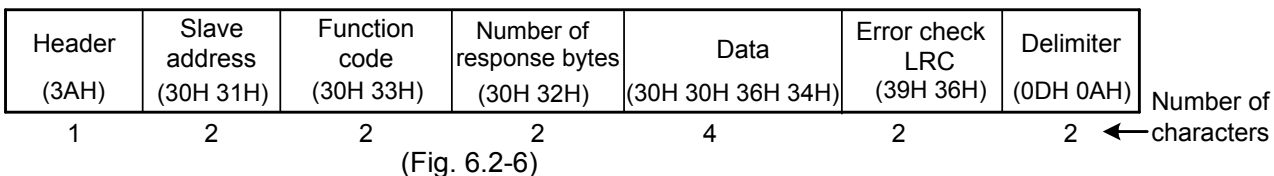

- A response message from the slave in abnormal status (When non-existent data item is sent)  
The function code MSB is set to 1 for the response message in abnormal status (Value: 83H, ASCII: 38H 33H).  
If an abnormal code (Value: 02H, ASCII: 30H 32H Non-existent data address) is returned, the error can be determined by reading this code.

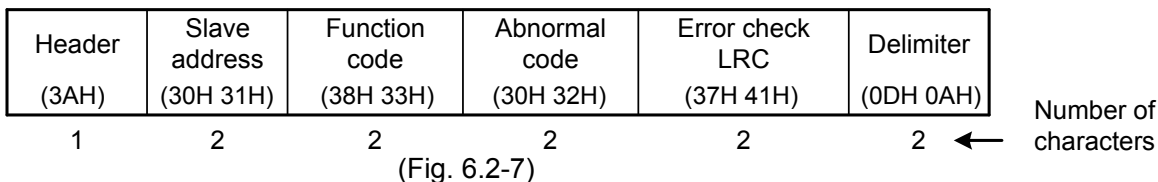

### ③ Setting (Address 1, SV1)

When setting SV1 to 100°C (0064H)

- A request message from the master

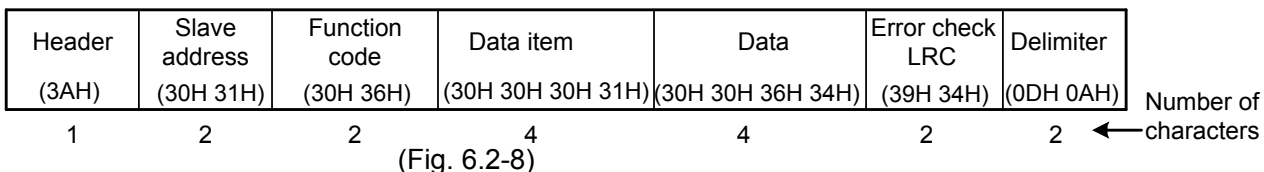

- A response message from the slave in normal status

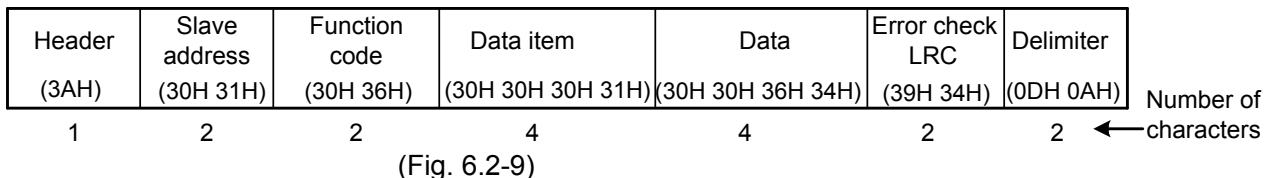

- A response message from the slave in abnormal status (When a value out of the setting range is set.)  
The function code MSB is set to 1 for the response message in abnormal status (Value: 86H, ASCII: 38H 36H).  
If an abnormal code (Value: 03H, ASCII: 30H 33H Value out of the setting range) is returned, the error can be determined by reading this code.

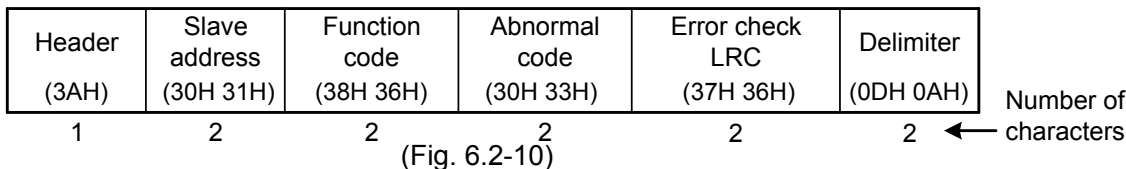

### 6.3 RTU mode

8-bit binary data in command is transmitted as it is.

Data format      Start bit            : 1 bit  
                          Data bit                : 8 bits  
                          Parity                        : No parity  
                          Stop bit                        : 1 bit  
                          Error detection : CRC-16 (Cyclic Redundancy Check)  
                          Data interval    : 3.5 characters transmission time or less

#### (1) Message configuration

RTU mode is configured to start after idle time is processed for more than 3.5 characters transmission and end after idle time is processed for more than 3.5 characters transmission. (See Fig. 6.3-1)

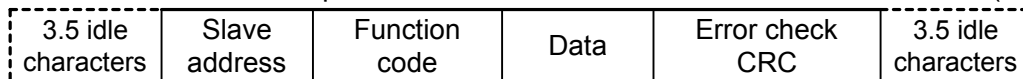

(Fig. 6.3-1)

#### Slave address

Slave address is an individual instrument number on the slave side and is set within the range 00H to 5FH (0 to 95).

The master identifies slaves by the slave address of the requested message.

The slave informs the master which slave is responding to the master by placing its own address in the response message.

[Slave address 00H (broadcast address) can identify all the slaves. However slaves do not respond.]

#### Function code

The function code is the command code that makes the slave to undertake the following action types (Table 6.3-1).

(Table 6.3-1)

Function code	Contents
03 (03H)	Reading the setting value and information from slaves
06 (06H)	Setting to slaves

A function code is used to discern whether the response is normal (acknowledgement) or if any error (negative acknowledgement) has occurred when the slave returns the response message to the master. When acknowledgement is returned, the slave simply returns the original function code.

When negative acknowledgement is returned, the MSB of the original function code is set as 1 for the response.

(For example, when the master sends request message setting 10H to function code by mistake, slave returns 90H by setting the MSB to 1, because the former is an illegal function.)

For negative acknowledgement, abnormal code (Table 6.3-2) below is set to the data of response message and returned to the master in order to inform it that what kind of error has occurred.

(Table 6.3-2)

Abnormal code	Contents
1 (01H)	Illegal function (Non-existent function)
2 (02H)	Illegal data address (Non-existent data address)
3 (03H)	Illegal data value (Value out of the setting range)
17 (11H)	Illegal setting (Unsettable status)
18 (12H)	Illegal setting (During setting mode by keypad, etc)

#### Data

Data differs depending on the function code.

A request message from the master side is composed of data item, number of data and setting data.

A response message from the slave side is composed of number of bytes, data and abnormal code in negative acknowledgement.

Only one piece of data can be dealt with per message. Therefore the number of data for RTU mode is fixed as (0001H). The number of response bytes is (02H).

Data item and data are the same as those defined in Chapter 7. Communication command table.

Effective range of data is -32768 to 32767 (8000H to 7FFFH).

#### (2) RTU mode error check

After calculating CRC-16 (Cyclic Redundancy Check) from the slave address to the end of data, the calculated 16-bit data is appended to the end of message in sequence from low order to high order.

### How CRC is calculated

In the CRC system, the information is divided by the polynomial. The remainder is added to the end of the information and transmitted. The generation of polynomial is as follows.

(Generation of polynomial:  $X^{16} + X^{15} + X^2 + 1$ )

- ① Initialize the CRC-16 data (assumed as X) (FFFFH).
- ② Calculate exclusive OR (XOR) with the 1st data and X. This is assumed as X.
- ③ Shift X one bit to the right. This is assumed as X.
- ④ When a carry is generated as a result of the shift, XOR is calculated by X of ③ and the fixed value (A001H). This is assumed as X. If a carry is not generated, go to step ⑤.
- ⑤ Repeat steps ③ and ④ until shifting 8 times.
- ⑥ XOR is calculated with the next data and X. This is assumed as X.
- ⑦ Repeat steps ③ to ⑤.
- ⑧ Repeat steps ③ to ⑤ up to the last data.
- ⑨ Set X as CRC-16 to the end of message in sequence from low order to high order.

### (3) RTU mode message example

#### ① Reading (Address 1, PV)

- Request message from the master

The number of data indicates the data item to be read, and it is fixed as (0001H).

3.5 idle characters	Slave address (01H)	Function code (03H)	Data item (0080H)	Number of data (0001H)	Error check CRC (85E2H)	3.5 idle characters
	1	1	2	2	2	

(Fig. 6.3-2)

- Response message from the slave in normal status [When PV=25°C (0019H)]

The number of response bytes indicates number of bytes of the data which has been read, and it is fixed as (02H).

3.5 idle characters	Slave address (01H)	Function code (03H)	Number of response bytes (02H)	Data (0019H)	Error check CRC (798EH)	3.5 idle characters
	1	1	1	2	2	

(Fig. 6.3-3)

#### ② Reading (Address 1, SV1)

- Request message from the master

The number of data indicates the data item to be read, and it is fixed as (0001H).

3.5 idle characters	Slave address (01H)	Function code (03H)	Data item (0001H)	Number of data (0001H)	Error check CRC (D5CAH)	3.5 idle characters
	1	1	2	2	2	

(Fig. 6.3-4)

- Response message from the slave in normal status [SV1=100°C (0064H)]

The number of response bytes indicates number of bytes of the data which has been read, and it is fixed as (02H).

3.5 idle characters	Slave address (01H)	Function code (03H)	Number of response bytes (02H)	Data (0064H)	Error check CRC (B9AFH)	3.5 idle characters
	1	1	1	2	2	

(Fig. 6.3-5)

- Response message from the slave in abnormal status (When data item is mistaken)

The function code MSB is set to 1 for the response message in abnormal status (83H).

If an abnormal code (02H: Non-existent data address) is returned, the error can be determined by reading this code.

3.5 idle characters	Slave address (01H)	Function code (83H)	Abnormal code (02H)	Error check CRC (C0F1H)	3.5 idle characters
	1	1	1	2	

(Fig. 6.3-6)

#### ③ Setting (Address 1, SV1)

When setting SV1 to 100°C (0064H)

- Request message from the master

3.5 idle characters	Slave address (01H)	Function code (06H)	Data item (0001H)	Data (0064H)	Error check CRC D9E1H	3.5 idle characters
	1	1	2	2	2	

(Fig. 6.3-7)

- Response message from the slave in normal status

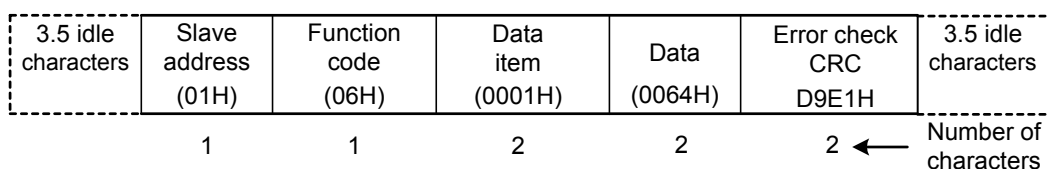

(Fig. 6.3-8)

- Response message from the slave in abnormal status (When a value out of the setting range is set)

The function code MSB is set to 1 for the response message in abnormal status (86H).

If an abnormal code (03H: Value out of the setting range) is returned, the error can be determined by reading this code.

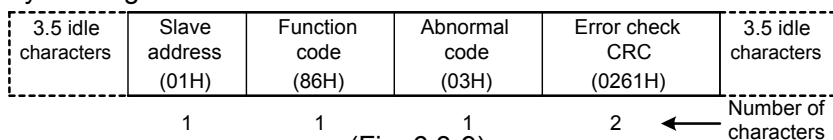

(Fig. 6.3-9)

## 7. Communication command table

Shinko command type	Modbus function code	Data item	Data
20H/50H	03H/06H	1110H: Step 1 SV setting	Setting value, Decimal point ignored
20H/50H	03H/06H	1111H: Step 1 time setting	Setting value, Decimal point ignored
20H/50H	03H/06H	1120H: Step 2 SV setting	Setting value, Decimal point ignored
20H/50H	03H/06H	1121H: Step 2 time setting	Setting value, Decimal point ignored
20H/50H	03H/06H	1130H: Step 3 SV setting	Setting value, Decimal point ignored
20H/50H	03H/06H	1131H: Step 3 time setting	Setting value, Decimal point ignored
20H/50H	03H/06H	1140H: Step 4 SV setting	Setting value, Decimal point ignored
20H/50H	03H/06H	1141H: Step 4 time setting	Setting value, Decimal point ignored
20H/50H	03H/06H	1150H: Step 5 SV setting	Setting value, Decimal point ignored
20H/50H	03H/06H	1151H: Step 5 time setting	Setting value, Decimal point ignored
20H/50H	03H/06H	1160H: Step 6 SV setting	Setting value, Decimal point ignored
20H/50H	03H/06H	1161H: Step 6 time setting	Setting value, Decimal point ignored
20H/50H	03H/06H	1170H: Step 7 SV setting	Setting value, Decimal point ignored
20H/50H	03H/06H	1171H: Step 7 time setting	Setting value, Decimal point ignored
20H/50H	03H/06H	1180H: Step 8 SV setting	Setting value, Decimal point ignored
20H/50H	03H/06H	1181H: Step 8 time setting	Setting value, Decimal point ignored
20H/50H	03H/06H	1190H: Step 9 SV setting	Setting value, Decimal point ignored
20H/50H	03H/06H	1191H: Step 9 time setting	Setting value, Decimal point ignored
20H/50H	03H/06H	0001H: SV1	Setting value, Decimal point ignored
20H/50H	03H/06H	0002H: Not used	
20H/50H	03H/06H	0003H: AT setting	0000H: Cancel 0001H: Perform
20H/50H	03H/06H	0004H: OUT proportional band setting	Setting value, Decimal point ignored
20H/50H	03H/06H	0005H: Cooling proportional band	Setting value, Decimal point ignored
20H/50H	03H/06H	0006H: Integral time setting	Setting value
20H/50H	03H/06H	0007H: Derivative time setting	Setting value
20H/50H	03H/06H	0008H: OUT proportional cycle setting	Setting value
20H/50H	03H/06H	0009H: Cooling proportional cycle	Setting value
20H/50H	03H/06H	000AH: Manual reset setting	Setting value, Decimal point ignored
20H/50H	03H/06H	000BH: A1 setting	Setting value, Decimal point ignored
20H/50H	03H/06H	000CH: A2 setting	Setting value, Decimal point ignored
20H/50H	03H/06H	000DH: Not used	
20H/50H	03H/06H	000EH: Not used	
20H/50H	03H/06H	000FH: Not used	
20H/50H	03H/06H	0010H: Not used	
20H/50H	03H/06H	0011H: Not used	

20H/50H	03H/06H	0012H: Setting value lock selection	0000H: Unlock 0001H: Lock 1 0002H: Lock 2 0003H: Lock 3
20H/50H	03H/06H	0013H: Not used	
20H/50H	03H/06H	0014H: Not used	
20H/50H	03H/06H	0015H: Sensor correction setting	Setting value, Decimal point ignored
20H/50H	03H/06H	0016H: Overlap band/Dead band setting	Setting value
20H/50H	03H/06H	0017H: Not used	
20H/50H	03H/06H	0018H: Scaling high limit setting	Setting value, Decimal point ignored
20H/50H	03H/06H	0019H: Scaling low limit setting	Setting value, Decimal point ignored
20H/50H	03H/06H	001AH: Decimal point place selection	0000H: No decimal point 0001H: 1 digit after decimal point 0002H: 2 digits after decimal point 0003H: 3 digits after decimal point
20H/50H	03H/06H	001BH: PV filter time constant setting	Setting value, Decimal point ignored
20H/50H	03H/06H	001CH: OUT high limit setting	Setting value
20H/50H	03H/06H	001DH: OUT low limit setting	Setting value
20H/50H	03H/06H	001EH: OUT ON/OFF action hysteresis setting	Setting value, Decimal point ignored
20H/50H	03H/06H	001FH: Not used	
20H/50H	03H/06H	0020H: Not used	
		0021H: Not used	
20H/50H	03H/06H	0022H: Cooling output ON/OFF action hysteresis setting	Setting value, Decimal point ignored
20H/50H	03H/06H	0023H: A1 action selection	0000H: No alarm action 0001H: High limit alarm 0002H: Low limit alarm 0003H: High/Low limits alarm 0004H: High/Low limit range alarm 0005H: Process high alarm 0006H: Process low alarm 0007H: High limit alarm with standby 0008H: Low limit alarm with standby 0009H: High/Low limits alarm with standby 000AH: Timer function 000BH: Pattern end output
20H/50H	03H/06H	0024H: A2 action selection	The same as A1 action selection
20H/50H	03H/06H	0025H: A1 hysteresis setting	Setting value, Decimal point ignored
20H/50H	03H/06H	0026H: A2 hysteresis setting	Setting value, Decimal point ignored
20H/50H	03H/06H	0027H: Not used	
20H/50H	03H/06H	0028H: Not used	
20H/50H	03H/06H	0029H: A1 action delayed timer	Setting value
20H/50H	03H/06H	002AH: A2 action delayed timer	Setting value
20H/50H	03H/06H	002BH: Not used	
20H/50H	03H/06H	002CH: Not used	
20H/50H	03H/06H	002DH: Not used	
20H/50H	03H/06H	002EH: Not used	
20H/50H	03H/06H	002FH: Not used	
20H/50H	03H/06H	0030H: Not used	
20H/50H	03H/06H	0031H: Not used	
20H/50H	03H/06H	0032H: Not used	
20H/50H	03H/06H	0033H: Not used	
20H/50H	03H/06H	0034H: Not used	
20H/50H	03H/06H	0035H: Not used	
20H/50H	03H/06H	0036H: Not used	
20H/50H	03H/06H	0037H: OUT/OFF, RUN/STOP selection	0000H: OUT (STOP) 0001H: OFF (RUN)
20H/50H	03H/06H	0038H: Not used	
20H/50H	03H/06H	0039H: Not used	

20H/50H	03H/06H	003AH: Not used	
20H/50H	03H/06H	003BH: Not used	
20H/50H	03H/06H	003CH: Not used	
20H/50H	03H/06H	003DH: Not used	
20H/50H	03H/06H	003EH: Not used	
20H/50H	03H/06H	003FH: Not used	
20H/50H	03H/06H	0040H: Not used	
20H/50H	03H/06H	0041H: Not used	
20H/50H	03H/06H	0042H: Alarm HOLD function selection	0000H: Alarm HOLD [Not used] 0001H: Alarm HOLD [Used]
20H/50H	03H/06H	0043H: Not used	
20H/50H	03H/06H	0044H: Input type selection	0000H: K [-200 to 370°C] 0001H: K [-199.9 to 400.0°C] 0002H: J [-200 to 1000°C] 0003H: R [0 to 1760°C] 0004H: S [0 to 1760°C] 0005H: B [0 to 1820°C] 0006H: E [-200 to 800°C] 0007H: T [-199.9 to 400.0°C] 0008H: N [-200 to 1300°C] 0009H: PL-II [0 to 1390°C] 000AH: C (W/Re5-26) [0 to 2315°C] 000BH: Pt100 [-199.9 to 850.0°C] 000CH: JPt100 [-199.9 to 500.0°C] 000DH: Pt100 [-200 to 850°C] 000EH: JPt100 [-200 to 500°C] 000FH: K [-320 to 2500°F] 0010H: K [-199.9 to 750.0°F] 0011H: J [-320 to 1800°F] 0012H: R [0 to 3200°F] 0013H: S [0 to 3200°F] 0014H: B [0 to 3300°F] 0015H: E [-320 to 1500°F] 0016H: T [-199.9 to 750.0°F] 0017H: N [-320 to 2300°F] 0018H: PL-II [0 to 2500°F] 0019H: C (W/Re5-26) [0 to 4200°F] 001AH: Pt100 [-199.9 to 999.9°F] 001BH: JPt100 [-199.9 to 900.0°F] 001CH: Pt100 [-300 to 1500°F] 001DH: JPt100 [-300 to 900°F] 001EH: 4 to 20mA DC [-1999 to 9999] 001FH: 0 to 20mA DC [-1999 to 9999] 0020H: 0 to 1V DC [-1999 to 9999] 0021H: 0 to 5V DC [-1999 to 9999] 0022H: 1 to 5V DC [-1999 to 9999] 0023H: 0 to 10V DC [-1999 to 9999]
20H/50H	03H/06H	0045H: Direct/Reverse action selection	0000H: Heating (Reverse action) 0001H: Cooling (Direct action)
20H/50H	03H/06H	0046H: Not used	
20H/50H	03H/06H	0047H: AT bias setting	Setting value, Decimal point ignored
20H/50H	03H/06H	0048H: ARW setting	Setting value
20H/50H	03H/06H	006FH: Key lock selection	0000H: Key enabled 0001H: Key locked
50H	06H	0070H: Key operation change flag clearing	0000H: No action 0001H: All clearing
20H	03H	0080H: PV (input value) reading	Current PV, Decimal point ignored
20H	03H	0081H: Control output MV (manipulated variable) reading	Control output MV, Decimal point ignored
20H	03H	0082H: Control output MV	Control output MV, Decimal point ignored
20H	03H	0083H: Current SV reading	Current SV, Decimal point ignored

20H	03H	0084H: Running step remaining time reading	Remaining time Decimal point ignored
20H	03H	0085H: Instrument status reading	$2^{15}$ to $2^0$ <u>0000 0000 0000 0000</u> $2^0$ digit: Control output (OUT) 0: OFF 1: ON (For current output, Not decided) $2^1$ digit: Cooling output 0: OFF 1: ON $2^2$ digit: A1 output 0: OFF 1: ON $2^3$ digit: A2 output 0: OFF 1: ON $2^4$ digit: Not used (Always 0) $2^5$ digit: Not used (Always 0) $2^6$ digit: Not used (Always 0) $2^7$ digit: Not used (Always 0) $2^8$ digit: Overscale 0: OFF 1: ON $2^9$ digit: Underscale 0: OFF 1: Run $2^{10}$ digit: OUT (STOP)/OFF (RUN) 0: OUT 1: OFF $2^{11}$ digit: During AT 0: OFF 1: AT $2^{12}$ digit: OFF key selection 0: OFF 1: PROC $2^{13}$ digit: Controller/Converter mode selection 0: Controller 1: Converter $2^{14}$ digit: Not used (Always 0) $2^{15}$ digit: Key operation change 0: No 1: Yes
20H	03H	0086H: Running step	Running step
20H	03H	0087H: Not used	
20H	03H	0088H: Not used	
20H	03H	00A0H: Not used	
20H	03H	00A1H: Instrument information reading	$2^{15}$ to $2^0$ <u>0000 0000 0000 0000</u> $2^0$ digit: Control output (OUT) 0: OFF 1: ON (For current output, Not decided) $2^1$ digit: Cooling function 0: Not applied 1: Applied $2^2$ digit: A1 function 0: Not applied 1: Applied $2^3$ digit: A2 function 0: Not applied 1: Applied $2^4$ to $2^{15}$ digit: Not used (Always 0)

**Data:**

- When the data (setting value) has a decimal point, remove the decimal point and represent it as a whole number, then express it in hexadecimal figures.
- When the alarm action type is changed, the alarm setting value returns to the default value. The alarm output status is also initialized.

**Note**

The settings by the front keypad and by communication function differ as follows.

- When data is changed by front keypad, the data that is related to the changed item is also changed automatically as shown in Example 1 below.

- When the data is changed by communication function, the related data does not change as shown in Example 2 below. (Only the changed data is altered.)

(Example 1) SV high limit: 1370°C

Step SV : 1000°C

When SV high limit is changed to 800°C by the front keypad, both SV high limit and Step SV are changed to 800°C.

(Example 2) SV high limit: 1370°C

Step SV : 1000°C

When SV high limit is changed to 800°C by communication function, SV high limit is changed to 800°C, however, Step SV is maintained at the same temperature 1000°C.

## 8. Specifications

Cable length	: Maximum communication distance 1.2km Cable resistance: Within 50Ω (The terminator is not necessary or 120Ω or greater on one side of the cable.)
Communication line	: Based on EIA RS-485
Communication method	: Half-duplex
Communication speed	: 9600bps (2400, 4800, 9600, 19200bps) Selectable by keypad
Synchronous system	: Start-stop synchronous
Code form	: ASCII, binary
Error correction	: Command request repeat system
Error detection	: Parity check, Checksum (LRC), CRC
Data format	: Start bit: 1 Data bit: 7, 8 Parity : Even, No parity Stop bit: 1

## 9. Troubleshooting

If any malfunctions occur, refer to the following items after checking the power supply to the master and the slave.

### • Problem: Communication failure

Check the following
The connection or wiring of communication is not secure.
Burnout on the communication cable or imperfect contact with the connector.
Communication speed of the slave does not coincide with that of the master.
The data bit, parity and stop bit of the master do not accord with those of the slave.
The instrument number (address) of the slave does not coincide with that of the command.
The instrument number (address) is duplicated in multiple slaves.
When communicating without using Shinko communication converter (IF-300-C5), make sure that the program is appropriate for the transmission timing.

### • Problem: Though it is able to communicate, the response is 'NAK'.

Check the following
Check whether a non-existent command code has been sent or not.
The setting command data goes outside the setting range of the slave.
The controller cannot be set when functions such as AT is performing.
The operation mode is under the setting mode by the front keypad.

If you have any inquiries, please consult our agency or the shop where you purchased the unit.

## SHINKO TECHNOS CO.,LTD. OVERSEAS DIVISION

Reg. Office : 1-2-48, Ina, Minoo, Osaka, Japan

Mail Address : P.O.Box 17, Minoo, Osaka, Japan

URL : <http://www.shinko-technos.co.jp>

E-mail : [overseas@shinko-technos.co.jp](mailto:overseas@shinko-technos.co.jp)

Tel : 81-72-721-2781

Fax: 81-72-724-1760