

To prevent accidents arising from the misuse of this instrument, please ensure the operator using it receives this manual.



Caution

- This instrument should be used according to the specifications described in the manual. If it is not used according to the specifications, it may malfunction or cause fire.
- Be sure to follow the warnings, cautions and notices. Not doing so could cause serious injury or malfunction.
- Specifications of the OMR-100 and the contents of this instruction manual are subject to change without notice.
- This instrument is designed to be installed in a control panel. If this is not the case, measures must be taken to ensure that the operator cannot touch power terminals or other high voltage sections.
- Be sure to turn the power supplied to the instrument OFF before cleaning this instrument.
- Use a soft and dry cloth when cleaning the instrument.
(If paint thinner is used, it might deform or tarnish the unit.)
- As the display section is vulnerable, do not strike or scratch it with a hard object.
- Any unauthorized transfer or copying of this document, in part or in whole, is prohibited.
- Shinko Technos CO., LTD. is not liable for any damages or secondary damages incurred as a result of using this product, including any indirect damages.

1. Overview

1.1 Overview of OMR-100

When the DCL-33A is connected to the console unit OMR-100, the DCL-33A can be monitored just as using Indicating controller JC □-33A series.

1.2 System configuration

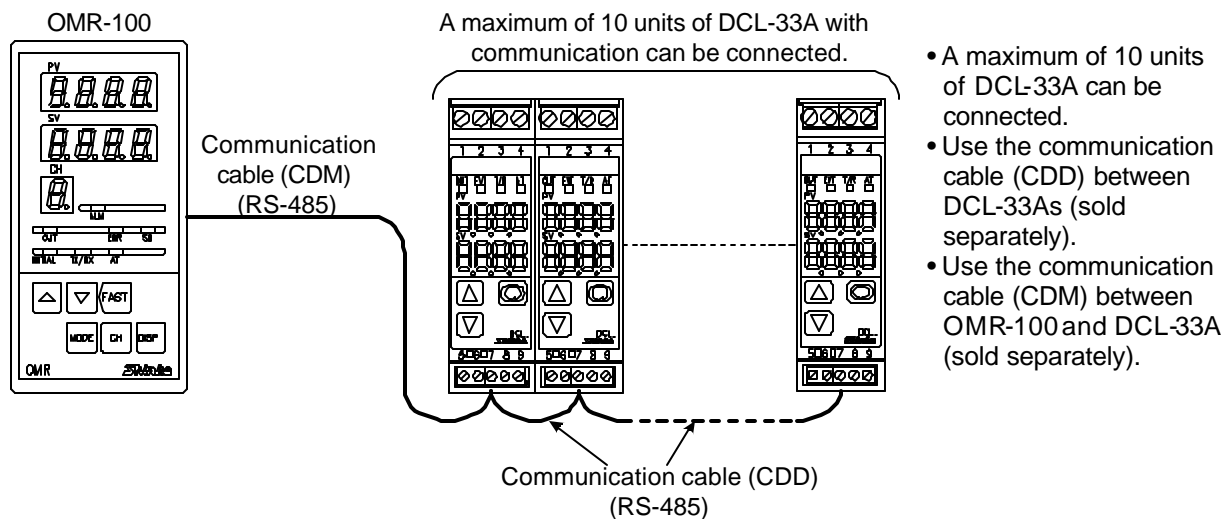

(Fig. 1.2-1)

1.3 Parameter exchange

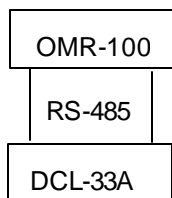

OMR-100 transmits command data to the DCL-33A and receives the response data from the DCL-33A.

DCL-33A receives transmitting data from OMR-100, and performs control, then sends the response data to the OMR-100.

(Fig. 1.3-1)

2. Model name

2.1 Model name

OMR-100: Console unit (for DCL-33A)

2.2 How to indicate model nameplate

Model nameplates are applied on the case and on the inner assembly.

For Heater burnout alarm output, CT rated current is entered in the bracket ().

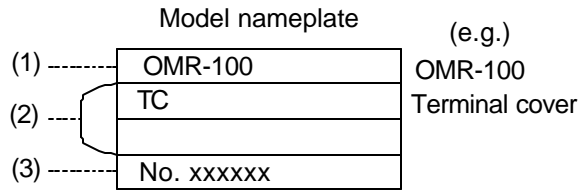

- (1) Model name
- (2) Option name (For supply voltage 24V AC/DC, enter "1")
- (3) Instrument number (only on the inner assembly)

3. Name and functions of the sections

- (1) **PV display:** Indicates the input value with a red LED.
- (2) **SV display:** Indicates the setting value with a green LED.
- (3) **CH display:** Indicates the channel number with a yellow LED.
- (4) **OUT indicator:** A green LED lights when control output of the channel indicated on the CH display is ON.
- (5) **INITIAL indicator:** While reading the setting value of DCL-33A, a yellow LED lights up.
- (6) **TX/RX indicator:** A yellow LED blinks during serial communication.
- (7) **ALM indicator:** A red LED lights up when the alarm output of the channel indicated on the CH display is ON.
- (8) **ERROR indicator:** A red LED blinks at intervals of 2 seconds when communication errors occur.
- (9) **SB indicator:** When sensor of the channel indicated on the CH display is burnt out, a red LED lights up.
- (10) **AT indicator:** When AT of the channel indicated on the CH display is performing, a yellow LED lights up.

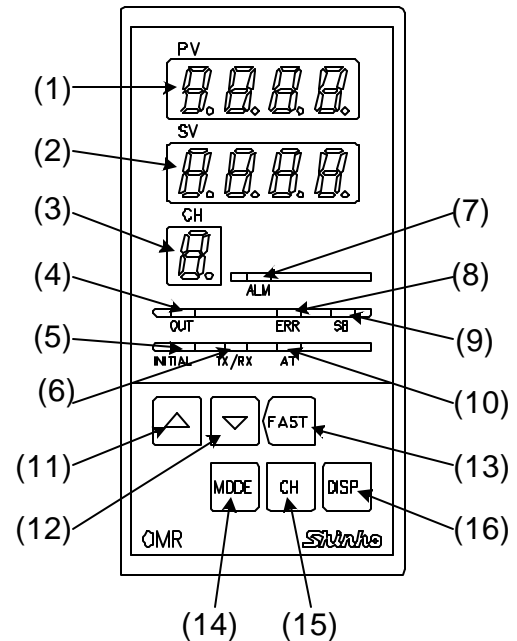

(Fig. 3-1)

- (11) **Increase key:** Increases the numeric setting value.
- (12) **Decrease key:** Decreases the numeric setting value.
- (13) **FAST key:** Makes the setting value change faster while simultaneously holding down either the Increase or Decrease key.
- (14) **MODE key:** Selects a setting mode or registers the setting value.
(To register the setting value or selected value, press the MODE key)
- (15) **CHANNEL key:** Selects the channel to indicate PV and SV.
Selects a channel number to be set in the setting mode.
- (16) **DISPLAY key:** Selects whether the channel to indicate PV and SV is switched automatically or manually.

Notice

When setting the specifications and functions of this instrument, connect the terminals 2 and 3 for power source first, then set them referring to "7. Setup" before performing "4. Mounting to control panel" and "5. Wiring".

4. Mounting to controlpanel

4.1 Site selection

This instrument is intended to be used under the following environmental conditions (IEC61010-1): **Overvoltage category II, Pollution degree 2**

Mount the instrument in a place with:

- A minimum of dust, and an absence of corrosive gases
- No flammable, explosive gasses
- Few mechanical vibrations or shocks
- No exposure to direct sunlight, an ambient temperature of 0 to 50°C (32 to 122°F) that does not change rapidly
- An ambient non-condensing humidity of 35 to 85%RH
- No large capacity electromagnetic switches or cables through which large current is flowing
- No water, oil or chemicals or where the vapors of these substances can come into direct contact with the instrument

4.2 External dimension

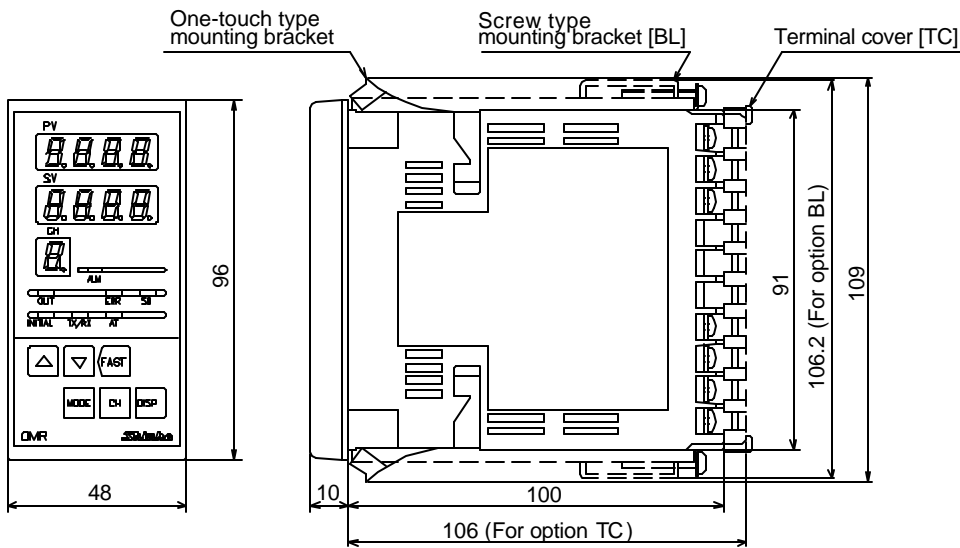

(Fig. 4.2-1)

4.3 Panel cutout

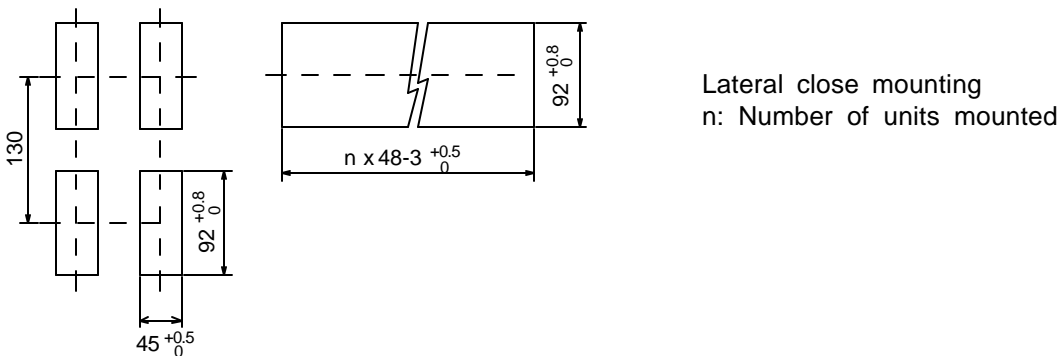

(Fig. 4.3-1)

4.4 Mounting



Warning

As the case is made of resin, do not use excessive force while screwing in the mounting bracket, or the case or screw type mounting bracket could be damaged.
The torque is approximately 0.12N•m.

When using one-touch type mounting bracket

Mountable panel thickness: Within 1 to 3mm
 Attach one-touch type mounting bracket (1) to the top and bottom of the instrument in advance, and insert the OMR-100 (2) from the front of the control panel.
 If soft front cover [FC-R-S] is used, the mounting panel thickness will be within 1 to 2.5mm.

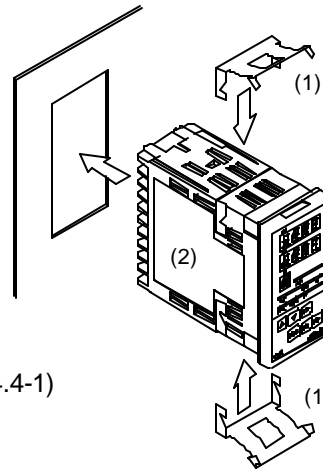

(Fig. 4.4-1)

When using screw type mounting bracket

Mountable panel thickness: Within 1 to 15mm
 Insert the OMR-100 from the front of the control panel.
 Attach the screw type mounting brackets by the holes at the top and bottom of the case and secure the instrument in place with the screws.
 If soft front cover [FC-R-S] is used, the mounting panel thickness will be within 1 to 14.5mm.

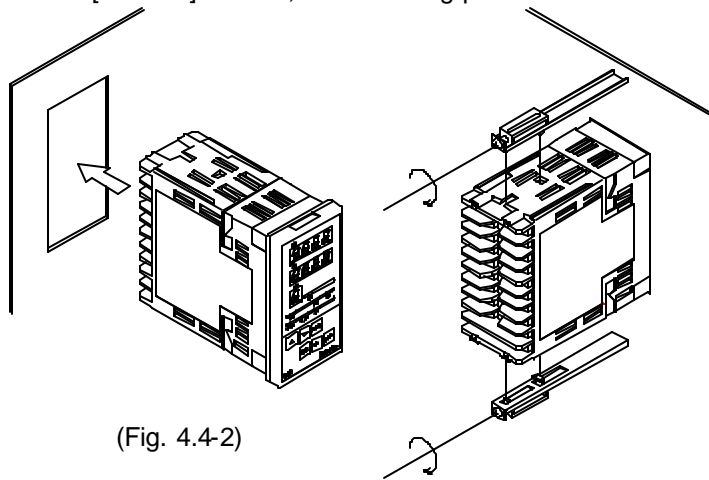

(Fig. 4.4-2)

5. Wiring



Warning

Turn the power supply to the instrument off before wiring or checking it.
 Working or touching the terminal with the power switched on may result in severe injury or death due to Electric Shock.

5.1 Terminal arrangement

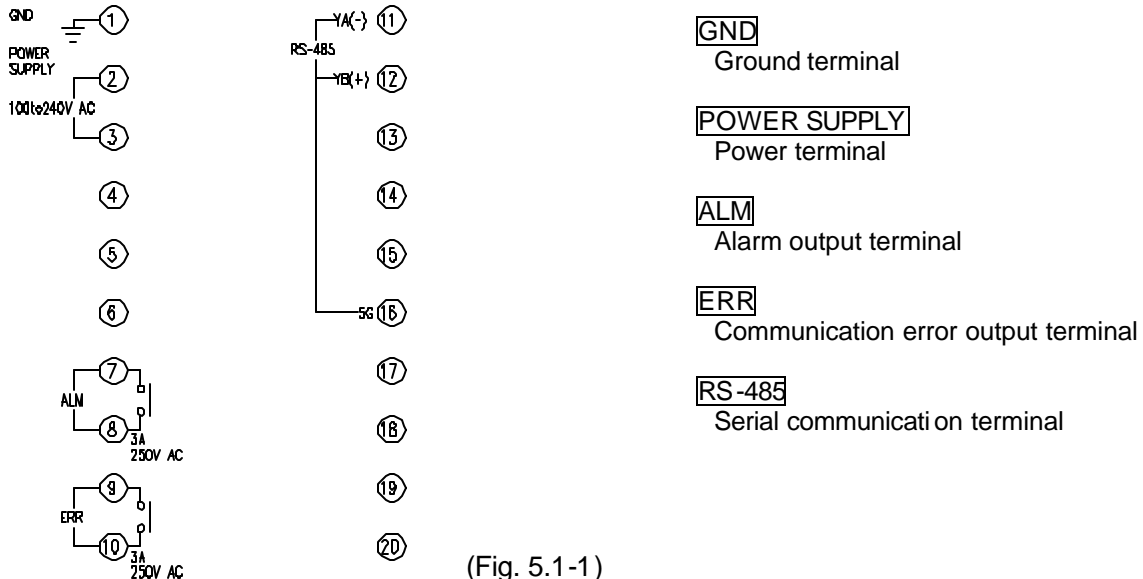

(Fig. 5.1-1)

⚠ Notice

- The terminal block of the OMR-100 is designed to be wired from the left side. The lead wire must be inserted from the left side of the terminal, and fastened by the terminal screw.
- Tighten the screw with less than the appropriate torque. If excess torque is used, the terminal screw may be damaged or the case may be deformed.
- **When using a 24V DC for the power source, do not confuse the polarity.**
- This instrument does not have built-in power switch, circuit breaker or fuse. Therefore, it is necessary to install them in the circuit near the external instrument.
(Recommended fuse: Time-lag fuse, rated voltage 250V AC, rated current 2A)

Lead wire solderless terminal

Use a solderless terminal with isolation sleeve that fits in the M3 screw as shown below.

Tightening torque should be 0.6N•m to 1.0N•m.

Solderless terminal	Manufacturer	Model name	Tightening torque
Y type	Nichifu Terminal Industries CO.,LTD.	1.25Y-3	0.6N•m Max. 1.0N•m
	Japan Solderless Terminal MFG CO.,LTD.	VD1.25-B3A	
Round type	Nichifu Terminal Industries CO.,LTD.	1.25-3	
	Japan Solderless Terminal MFG CO.,LTD.	V1.25-3	

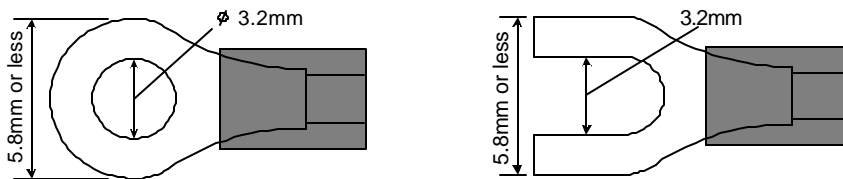

(Fig. 5.1-1)

5.2 Wiring example

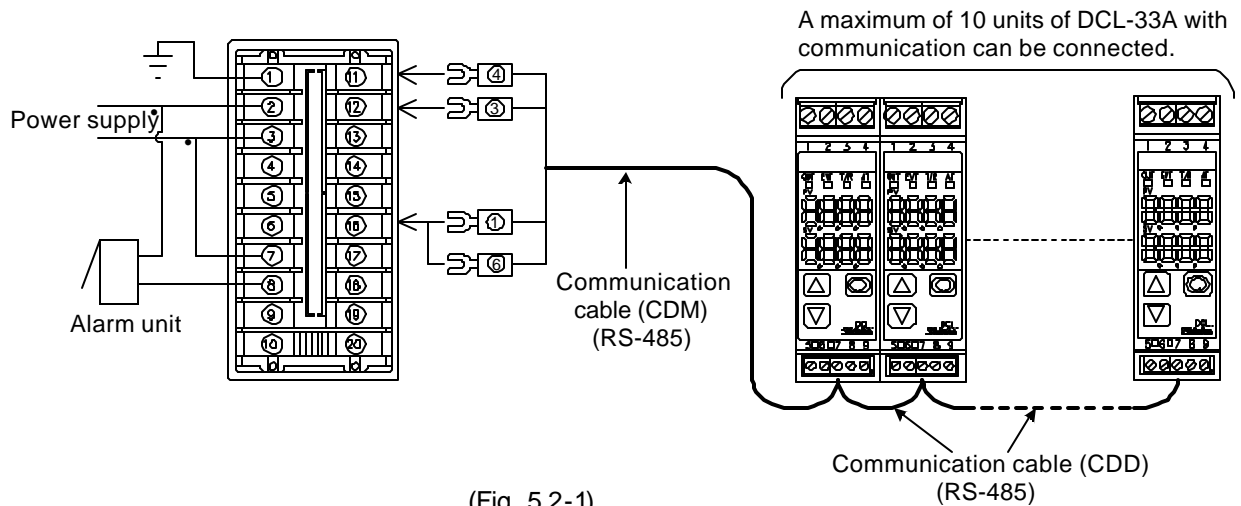

(Fig. 5.2-1)

6. Operation flow chart

Outline of operation procedure

Operation before running

- [Step 1 Communication speed setting]: Communication speed for OMR-100 is fixed to 19200bps. Therefore, set communication speed for DCL-33A to 19200bps. (Refer to the instruction manual for DCL-33A for the communication speed setting.)
- [Step 2 Instrument number setting]: Set the instrument number of the DCL-33A. The number must be started from "0".
- [Step 3 Number of connected units setting]: Set the number of connected DCL-33A units during the Number of connected units setting mode.
- [Step 4 Setting item]: Set SV, Alarm value, PID values, etc. of each DCL-33A in the Main setting mode.
- [Step 5 AT setting]: Set whether performing AT of each DCL-33A or not in the Sub setting mode. (If Step 5 is not necessary, skip this step.)

How to set the number of connected units

- Press **MODE** key for approx. 3 seconds while holding down the **▼** key when OMR-100 is in PV/SV display mode. PV display indicates [Unit], and SV indicates the number of currently connected units. (The mode will become the Number of connected units setting mode.)
- Set the number of connected units of DCL-33A by pressing **▲** or **▼** key during the Number of connected units setting mode. (The figure on the SV display shows the number of DCL-33A units connected.)
- After finishing the connected units setting, press the **MODE** key. The mode will revert to the PV/SV display mode.

How to read all setting values of DCL-33A

- When OMR-100 is in PV/SV display mode, press the **MODE** key for approximately 3 seconds while holding down **▲** and **▼** keys.
- In the All setting values reading mode, the INITIAL indicator lights up. While the INITIAL indicator is lit, OMR-100 is reading all setting values of DCL-33A connected.

Explanation of **MODE** key

MODE This means that if **MODE** key is pressed, the setting value is saved and the instrument proceeds to the next setting item.

PV/SV display

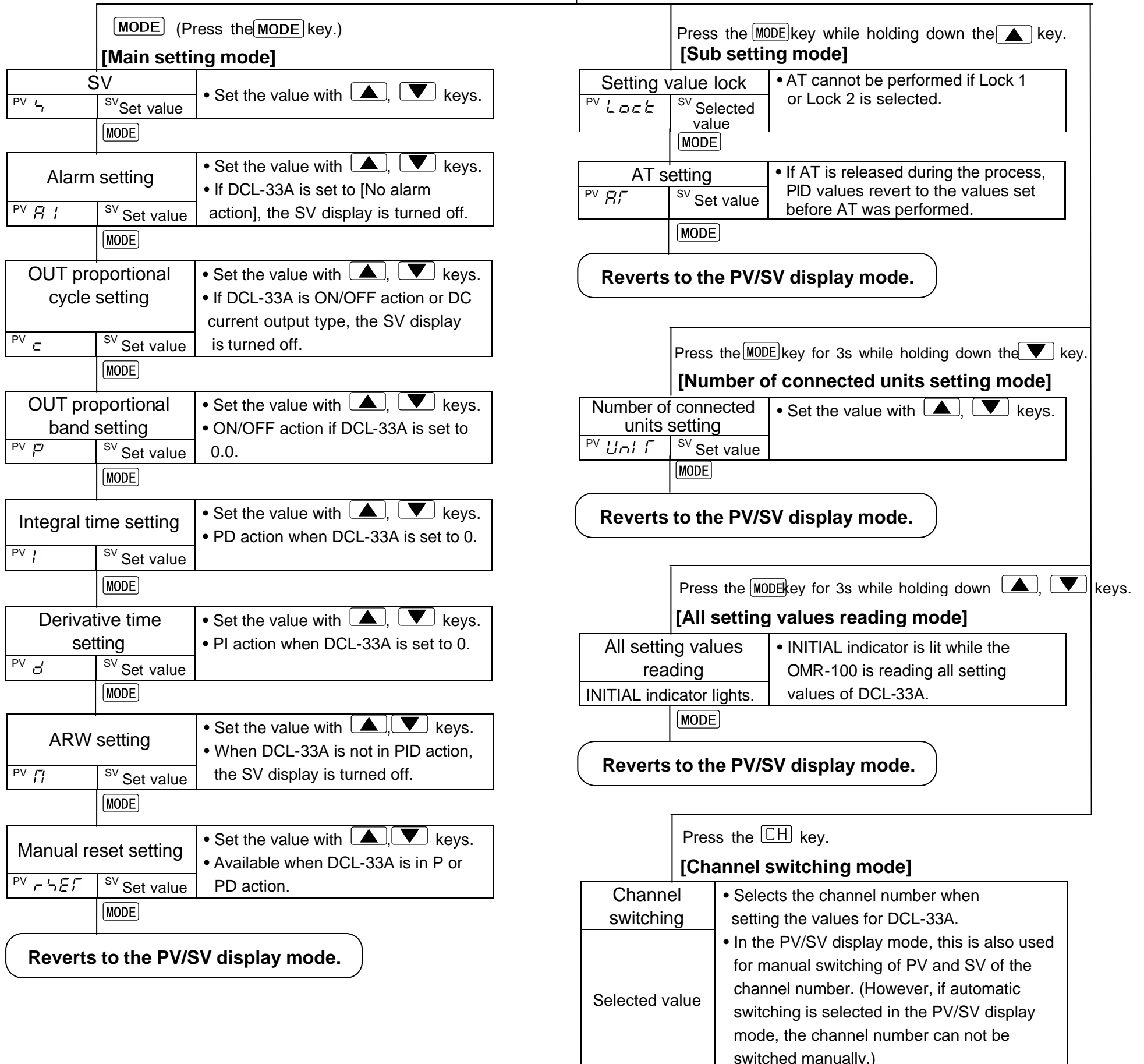

7. Setup

Set up the following after turning the power to the OMR-100 ON.

- The communication speed of OMR-100 is set to 19200bps. Therefore communication speed of all connected DCL-33A units must be set to 19200bps.

(For the communication speed setting for the DCL-33A, refer to its instruction manual.)

- Set the instrument number of DCL-33A.

(The number should start from “0” and be in sequence in setting the connected units to the instrument numbers.)

(e.g.) If 5 units of DCL-33A are connected to OMR-100, the instrument numbers for DCL-33A are 0 to 4.

- Set the number of connected DCL-33A units.

If the number of connected units is not set to OMR-100, only one DCL-33A unit will be monitored even though multiple DCL-33A are connected.

7.1 Main setting mode

Call up the Main setting mode, and select a channel to be set by pressing **[CH]** key before setting each item.

(e.g.) When setting SV and Alarm setting value for CH3

Press the **[MODE]** key first to call up the Main setting mode.

Then, select CH3 by pressing the **[CH]** key. (3 is indicated on the CH display.)

Set SV and Alarm setting value for CH3 after selecting CH3.

Character (PV display)	Name, Function, Setting range
↳ R I	SV <ul style="list-style-type: none"> • Sets SV of the DCL-33A. • Scaling low limit value to Scaling high limit value Alarm setting <ul style="list-style-type: none"> • Sets alarm output action point of the DCL-33A. • Not available when set to 0 or 0.0 (except for Process high and process low alarms) • SV display is turned off if DCL-33A of the selected channel number is set to No alarm action (No alarm action has been selected during Alarm action selection for the DCL-33A.) • Refer to (Table 7.1-1).
ε	OUT proportional cycle setting <ul style="list-style-type: none"> • Sets proportional cycle of the DCL-33A. • DCL-33A of the selected channel number is ON/OFF action or DC current output type, SV display is turned off. • 1 to 120 seconds
ρ	OUT proportional band setting <ul style="list-style-type: none"> • Sets proportional band of the DCL-33A. • ON/OFF action of the DCL-33A when set to 0.0. • 0.0 to 110.0%
I	Integral time setting <ul style="list-style-type: none"> • Sets the integral time of the DCL-33A. • Setting the value to 0 disables integral action of the DCL-33A. • SV display is turned off when DCL-33A of the selected channel number is in ON/OFF action. • 0 to 1000 seconds
d	Derivative time setting <ul style="list-style-type: none"> • Sets the derivative time of the DCL-33A. • Setting the value to 0 disables derivative action of the DCL-33A. • SV display is turned off when DCL-33A of the selected channel number is in ON/OFF action. • 0 to 300 seconds
∩	Anti-reset windup setting <ul style="list-style-type: none"> • Sets the anti-reset windup of the DCL-33A. • Setting the value to 0 disables anti-reset windup action of DCL-33A. • SV display is turned off when DCL-33A of the selected channel number is not in PID action. • 0 to 100%

r4Er	Manual reset setting <ul style="list-style-type: none"> • Sets the reset value of the DCL-33A manually. • This setting item is indicated only when DCL-33A of the selected channel number is P or PD action. • \pm Proportional band converted value
------	---

(Table 7.1-1)

Alarm action type	Setting range
High limit alarm	–(Scaling span) to scaling span
Low limit alarm	–(Scaling span) to scaling span
High/Low limits alarm	0 to scaling span
High/Low limit range alarm	0 to scaling span
Process high alarm	Scaling low limit value to scaling high limit value
Process low alarm	Scaling low limit value to scaling high limit value
High limit alarm with standby	–(Scaling span) to scaling span
Low limit alarm with standby	–(Scaling span) to scaling span
High/Low limits alarm with standby	0 to scaling span

• The negative low limit setting value is –199.9 or –1999 and the positive high limit setting value is 999.9 or 9999.

7.2 Sub setting mode

Call up Sub setting mode, then select a channel to set AT Perform by pressing CH key before setting AT Perform.

(e.g.) When performing AT for CH5

Call up the Sub setting mode by pressing MODE key while holding down the ▲ key.

Select CH5 by pressing the CH key. (5 is indicated on the CH display.)

Then select AT Perform.

Character (PV display)	Name, Function, Setting range
Lock	Setting value lock selection <ul style="list-style-type: none"> • Locks the setting values to prevent setting errors. The setting item to be locked depends on the designation. • When Lock 1 or Lock 2 is designated, PID Auto-tuning or Auto-reset cannot be carried out. • - - - - (Unlock): All setting values can be changed. • Lock 1 (Lock 1): None of the setting values can be changed. • Lock 2 (Lock 2): Only main setting mode can be changed. • Lock 3 (Lock 3): All setting values can be changed. However, they return to their former value after power is turned off because they are not saved in the non-volatile memory. Be sure to designate Lock 3 when changing the setting value frequently via communication function because this has no relation to the memory life.
AT	AT setting <ul style="list-style-type: none"> • Performs PID auto-tuning of the DCL-33A. However, if auto-tuning does not finish in 4 hours after it is started, it is cancelled automatically. • SV display is turned off when DCL-33A of the selected channel number is not PID action. • PID auto-tuning Cancel : - - - - PID auto-tuning Perform: AT

7.3 Number of connected units setting mode

Make sure to set "Number of connected units" first after turning the power to the OMR-100 ON.

Character (PV display)	Name, Function, Setting range
<i>Unit</i>	<p>Number of connected units setting</p> <ul style="list-style-type: none"> • Sets the number of connected DCL-33A units. If the number of connected units is not set to OMR-100, only one DCL-33A unit will be monitored even though multiple DCL-33A are connected. • 1 to 10 units (CH display indicates 1 to 9) <p>How to set the number of connected units</p> <ul style="list-style-type: none"> • Press [MODE] key for approx. 3 seconds while holding down the [▼] key while OMR-100 is in PV/SV display mode. PV display indicates [<i>Unit</i>], and SV indicates the number of currently connected units. (The mode will become Number of connected units setting mode.) • Set the number of DCL-33A by pressing [▲] or [▼] key during the Number of connected units setting mode. (The SV display shows the number of DCL-33A units connected.) • After finishing setting the number of connected units, press the [MODE] key. The mode will revert to the PV/SV display mode.

7.4 All setting values reading mode

Name, Function, Setting range	
<p>All setting values reading</p> <ul style="list-style-type: none"> • When the power to the OMR-100 (when the number of connected DCL-33A units has been set during the Number of connected units setting) and DCL-33A are turned ON at the same time, the OMR-100 automatically reads the setting value of DCL-33A and makes the values of OMR-100 equal to those of DCL-33A. • If the power to the DCL-33A is turned ON first, then the power to the OMR-100 is turned ON later, the OMR-100 begins to read the setting values of the DCL-33A after approximately 5 minutes. <p>How to read all setting values</p> <ul style="list-style-type: none"> • Press the [MODE] key for approximately 3 seconds while holding down the [▲] and [▼] keys in the PV/SV display mode. • INITIAL indicator lights up during All setting values reading mode. While the INITIAL indicator is lit, OMR-100 is reading all setting values of DCL-33A. 	

8. Running

After the DCL-33A has been mounted to the control panel (DIN rail) and wiring between OMR-100 and DCL-33A is complete, it can be started in the following manner.

(1) Turn the power supply to the OMR-100 and DCL-33A ON.

Turn the power supply to the OMR-100 and DCL-33A ON simultaneously.

- For approx. 5 seconds after the power is switched ON, [*err*] is indicated on the PV display.
During this time, all outputs and LED indicators are in OFF status.
- After that, OMR-100 automatically reads the setting values of DCL-33A and makes the values of OMR-100 equal to those of DCL-33A.

(2) Input or change each setting value.

Input or change each setting value, referring to Chapters "6. Operation flow chart" and "7. Setup".

(3) Turn the load circuit power ON.

DCL-33A starts controlling action so as to keep the temperature of the controlled object at the main setting value.

9. Specifications

9.1 Standard specifications

Model	Console unit
Name	OMR-100
Setting	Input by membrane sheet
Display	PV display: Red LED 4-digit. Character size: 8 x 4mm (H x W) SV display: Green LED 4-digit. Character size: 8 x 4mm (H x W) CH display: Yellow LED 1-digit. Character size: 8 x 4mm (H x W)

Serial communication

Communication line	: Based on RS-485
Communication method	: Half-duplex communication start-stop synchronous
Communication speed	: 19200bps
Data format	Start bit : 1 Data bit : 7 Parity : Even Stop bit : 1
Transmitted contents	: SV, Alarm setting value, OUT proportional cycle setting value, OUT proportional band setting value, Integral time setting value, Derivative time setting value, ARW setting value, Manual reset setting value, Setting value lock selection, AT Perform/Cancel
Received contents	: Above transmitted contents, PV, Status flag (Output status, Overscale, Underscale, DuringAT)

Alarm output Turns ON when alarm is activated.

(OR output common to all channels)

Relay contact: 1a, Control capacity; 3A 250V AC (resistive load)
1A 250V AC (inductive load $\cos\phi=0.4$)
Electrical life; 100,000 times

Communication error output Turns ON when communication errors occur.

Relay contact: 1a, Control capacity; 3A 250V AC (resistive load)
1A 250V AC (inductive load $\cos\phi=0.4$)
Electrical life; 100,000 times

Control Control action

- PID action (with auto-tuning function)
 - PI action: When derivative time is set to 0
 - PD action (with manual reset function): When integral time is set to 0
 - P action (with manual reset function): When integral and derivative times are set to 0
 - ON/OFF action: When proportional band is set to 0
- OUT proportional band (P): 0.0 to 110.0% (ON/OFF action when set to 0.0)
- Integral time (I) : 0 to 1000s (off when set to 0)
- Derivative time (D) : 0 to 300s (off when set to 0)
- OUT proportional cycle : 1 to 120s
- ARW : 0 to 100%
- Manual reset : \pm Proportional band converted value

Isolation and Dielectric strength Circuit isolation configuration

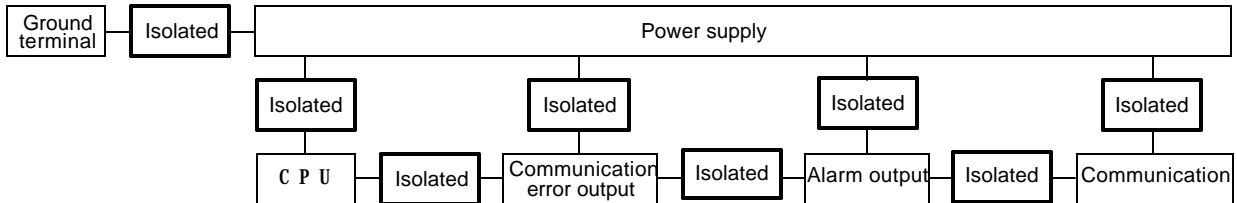

Isolation resistance : 10MΩ or greater at 500V DC

Dielectric strength : Between input terminal and power terminal, 1.5kV AC for 1 minute
Between output terminal and power terminal, 1.5kV AC for 1 minute

Supply voltage : 100 to 240V AC 50/60Hz, 24V AC/DC 50/60Hz

Allowable voltage fluctuation range

100 to 240V AC : 85 to 264V AC
24V AC/DC : 20 to 28V AC/DC

Power consumption : Approx. 5VA

Ambient temperature: 0 to 50°C (32 to 122°F)

Ambient humidity : 35 to 85%RH (no condensation)

Weight : Approx. 320g

External dimension : 48 x 96 x 100mm (W x H x D)

Material : Case, Flame resistant resin

Color : Case, Light gray

Attached function:

[Power failure countermeasure]

The setting data is backed up in non-volatile IC memory.

[Self-diagnosis]

The CPU is monitored by a watchdog timer, and when any abnormal status is found on the CPU, the controller is switched to warm-up status with all outputs OFF.

[Error indication when setting value change]

- When the setting value of the OMR-100 is changed
When the OMR-100 transmits the setting value to the DCL-33A, the setting value cannot be transmitted to the DCL-33A if the DCL-33A is in the setting mode. The OMR-100 finishes the setting mode and indicates [Err5] on the PV display of the OMR-100 for approximately 2 seconds. At this time, the OMR-100 reads all setting values of the corresponding DCL-33A and makes the setting values of the OMR-100 equal to those ones read from the DCL-33A.
- When the setting value of the DCL-33A is changed
If the OMR-100 detects the setting value change of the DCL-33A, the OMR-100 reads all setting values of the DCL-33A.
If DCL-33A is still in the setting mode after the OMR-100 reads all setting values of the DCL-33A, the OMR-100 indicates [Err5] on its PV display.
If the setting mode of the DCL-33A is finished, [Err5] disappears and the OMR-100 starts to read all setting values of corresponding DCL-33A.

[Indicated value during communication error]

- When the power to the OMR-100 is turned ON, if the power to the DCL-33A is turned OFF or if its communication cable is not connected, communication between OMR-100 and DCL-33A cannot be carried out. Therefore "0" is indicated for the PV and all setting values of DCL-33A while OMR-100 is reading DCL-33A data. After the data reading ends, PV display of OMR-100 is turned OFF.
- During normal communication, PV display of the OMR-100 is turned OFF for the channels which have not responded.
(The OMR-100 can read all setting values from the DCL-33A if the power to the OMR-100 is resupplied or a reading of all setting values is conducted after the wiring has been corrected. The OMR-100 also sends commands every 5 minutes to channels which have not responded. If a normal response is returned, the OMR-100 can read all setting values of the DCL-33A.)

Accessories	Instruction manual	1 copy
	Mounting bracket	1 set (One-touch type mounting bracket is standard.) When option BL is added, screw type mounting bracket is provided.
	Terminal cover	1 piece (When option TC is added.)

10. Troubleshooting

If any malfunctions occur, refer to the following items after checking the power of the OMR-100.

Indication

Problem	Presumed cause and solution
The indication of PV display is abnormal or unstable. ERR indicator is lit.	<ul style="list-style-type: none"> • There may be equipment producing an inductive fault or noise near the OMR-100. Keep the equipment producing an inductive fault or noise away from the OMR-100. • The connection or wiring of communication cable (CDM) is not secure. Wire it securely or change the communication cable (CDM). • The communication speed of the OMR-100 does not coincide with that of DCL-33A. Set the communication speed of the DCL-33A to 19200bps.

Key operation

Problem	Presumed cause and solution
Unable to set SV, PID values, alarm setting value, etc.	<ul style="list-style-type: none"> • DCL-33A is performing AT. Cancel the AT.

Control (Refer to the Instruction manual for DCL-33A)

Problem	Presumed cause and solution
If the control output remains ON status.	<ul style="list-style-type: none"> • OUT low limit value is set to 100% or greater. Set the value appropriately.
If the control output remains OFF status.	<ul style="list-style-type: none"> • OUT high limit value is set to 0% or less. Set the value appropriately.

If any unexplained malfunctions occur, make inquiries at our agency or us.

Shinko
North America Ltd.

Web Site: www.shinkona.com

25 Whitefriars Drive
Toronto, Ontario, Canada M3A 2L2
TEL: 416 444-0817
FAX: 416 444-2361
TOLL FREE: 1 888-4SHINKO

Email: sales@shinkona.com