

INSTRUCTION MANUAL
FOR
MICROCOMPUTER BASED
PROGRAMMABLE CONTROLLER
PC-900

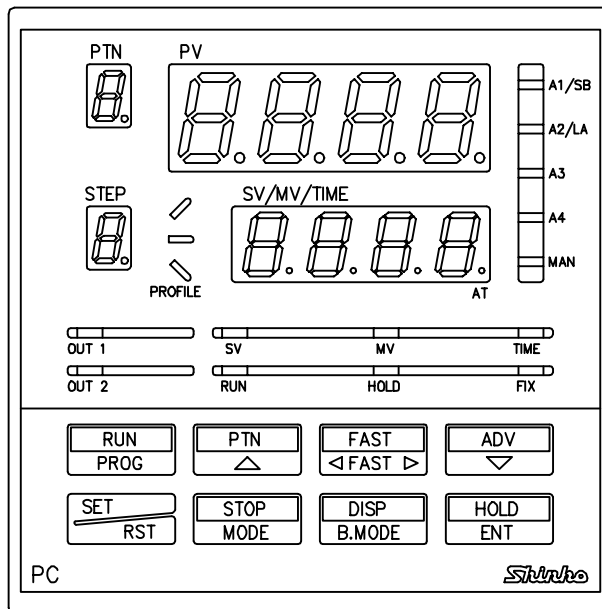

Thank you for your purchase of our Microcomputer based Programmable Controller **PC-900**. This manual contains instructions for the mounting, functions, operations and notes when operating the **PC-900**.

For your confirmation of the model and specifications of the controller, please peruse and make sure you understand this instruction manual before starting operation.

To prevent accidents arising from the use of this controller, please ensure the operator who uses it receives this manual.

******* Notes to users *******

Before operating this controller, please understand about following matters.

**Warning**

Turn the power supplied to the instrument OFF before wiring or checking. If working or touching the terminal with the power switched to ON, there is a possibility of Electric Shock, which can cause severe injury or death.

Moreover, the instrument must be grounded before the power supplied to the instrument is turned on.

**Caution**

Do not apply a commercial power source to the sensor connected to the input terminal nor allow the power source to come into contact with the sensor.

**Notices**

- Set-up of the Rotary switch and the DIP switch inside the controller is required before the power is turned on. The product is factory adjusted as [Sensor input: K, Control action: PID (with Auto-tuning function), Heating action, Alarm (A1): Pattern end output, Alarm (A3): High limit alarm output, Alarm (A4): Low limit alarm output, Unit:°C]. Refer to page 9, "Set-up".
- It is recommended that the PID auto-tuning is performed on the trial run.
- It is advisable to utilize protective devices against such environmental conditions which may cause damage to the device or the deterioration of its parts.
- In case of the PC-955 model, set the Open and Closed output time to meet the specification of the control valve.

-- CONTENTS--

1. Model names	
1.1 Explanation of the model names -----	4
1.2 How to indicate the model nameplate -----	5
2. Name and functions of the sections	
3. Set-up -----	6
4. Mounting to control panel -----	9
4.1 Site Selection -----	13
4.2 External dimension drawing, Panel cutout drawing -----	13
4.3 Mounting -----	13
5. Wiring connection	
5.1 Terminal arrangement -----	14
5.2 Wiring connection -----	17
6. Operations	
6.1 Operation flow chart -----	19
6.2 Key operation when setting -----	21
6.3 Program pattern setting -----	21
6.4 How to clear the setting -----	25
6.5 Block data Setting -----	26
• PID block data setting -----	26
• Time signal block data setting -----	29
• Wait block data setting -----	32
• Alarm block data setting -----	35
• Output block data setting -----	38
6.6 Number of repeat of the pattern and Pattern link setting -----	41
6.7 Attached function setting -----	43
• Alarm parameter setting -----	43
• Output parameter setting -----	48
• Main setting value limit setting -----	54
• Transmission output parameter setting -----	56
• Input parameter setting -----	59
• Communication parameter setting -----	63
• Other function setting -----	66
6.8 Fixed value control parameter setting -----	75

7. Running	
7.1 Program setting -----	82
7.2 Program control running -----	83
7.3 Fixed value control running -----	85
7.4 Manual control performance -----	86
7.5 SV/MV/TIME display change -----	88
7.6 Notes when PID auto-tuning is performing -----	89
7.7 PID auto-tuning performance/cancellation -----	90
8. Explanation of Control action and Alarm action	
8.1 Fuzzy overshoot suppressing PID action -----	92
8.2 PID and ARW -----	92
8.3 PID auto-tuning of this instrument -----	93
8.4 Standard action drawing -----	95
8.5 ON/OFF action drawing -----	96
8.6 Heating, Cooling action drawing -----	97
8.7 Action drawing when setting Open/Closed output dead band -----	101
8.8 Pattern end action drawing -----	101
8.9 Alarm 1 to 4 (A1 to A4) action drawing -----	102
9. Other functions -----	104
10. Specification	
10.1 Standard specification -----	105
10.2 Optional specification -----	109
11. When troubled -----	113
12. Initial values -----	116
Index 1 (Program control) -----	122
Index 2 (Fixed value control) -----	124
Program pattern graphing -----	125

1. Model names

1.1 Explanation of the model names

Alphanumeric character to represent the function or type is applied to the .

[Example]

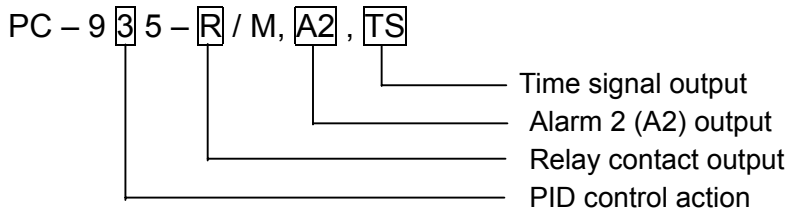

Standard model names

PC- 9 <input type="checkbox"/> 5 - <input type="checkbox"/> /M, <input type="checkbox"/>		Series name: PC-900 [96x96x100mm (WxHxD)]		
Control action	3		PID auto-tuning	
	5		ON/OFF servo output PID	
Alarm action	5		Alarm 3: High limit, Alarm 4: Low limit (*1)	
Control output		R	Relay contact output: 1a 1b (PC-935) or 1a x 2 (PC-955) (*2)	
		S	Non-contact voltage output (for SSR drive): 12 ⁺² ₀ Vdc	
		A	Current output: 4 to 20mAdc	
Input		M	Multi-range input (*3)	
Option		A2	Alarm 2 (including Pattern end output 2) (*4, *5)	
		LA	Loop break alarm (*5, *7)	
		DR	Relay contact: 1a Non-contact voltage (SSR drive): 12 ⁺² ₀ Vdc Current: 4 to 20mAdc	Control output (OUT2) (*4, *6)
		DS		
		DA		
		DA		
		TA	Current (4 to 20 mAdc) Voltage (0 to 1 Vdc)	Transmission output
		TV		
		C5	Based on EIA RS-485 Based on EIA RS-232C	Serial communication
		C		
		SVTC	Setting value digital transmission	
		TS	Time signal output	
		BK	Color: Black	
		IP	Dust-proof, Drip-proof	
	TC	Electrical shock protecting terminal cover		
	Designated specification (Shipped as designated)	Input range		
		Alarm action		
		Cooling action, applicable to option DR, DS or DA		
		Transmission		

(See page 109 for the contents of the options in detail.)

(*1): 12 types of alarm action, no alarm action or pattern end output are selectable by internal rotary switch and DIP switch.

(*2): The control output of the type PC-955 is available to the relay contact output only.

(*3): 16 types of input, Thermocouple, RTD, Current and Voltage are selectable by internal rotary switch and DIP switch.

(*4): This option is not available to the type PC-955.

(*5): When option A2 and LA are applied together, the output terminal are common.

(*6): This option is not available with a combination of the option A2 or LA.

(*7): In case of PC-955 type, the LA lamp lights when abnormal status, but there is no output.

1.2 How to indicate the model nameplate



Warning

Do not take the inner assembly out nor touch the terminal with the power supply on. If touching the terminal with the power on status, there is a possibility of Electric Shock which can cause severe injury or death.

Model nameplates are put on the case and the left side of the inner assembly.

Model nameplate (Example)

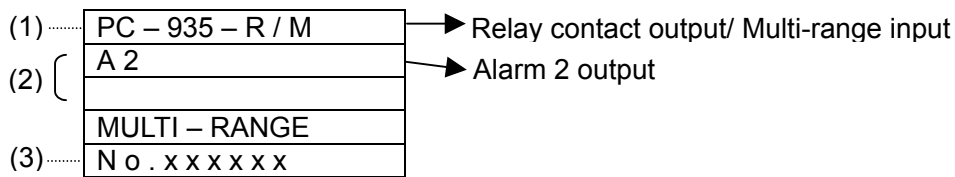

- (1): Model name
- (2): Option codes
- (3): Instrument number (Indicated only on internal assembly)

2. Name and Function of the sections

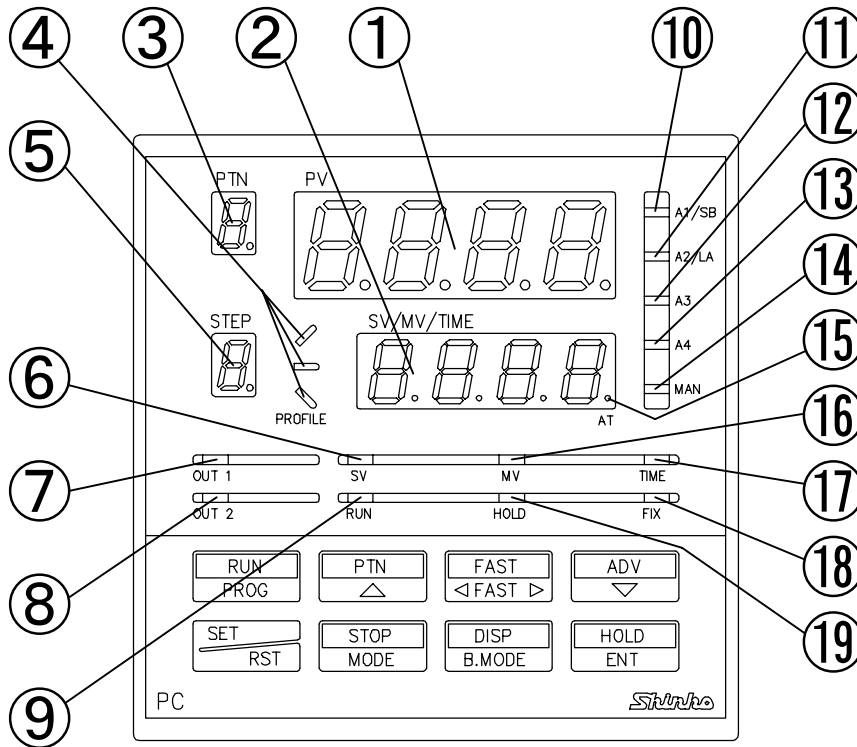







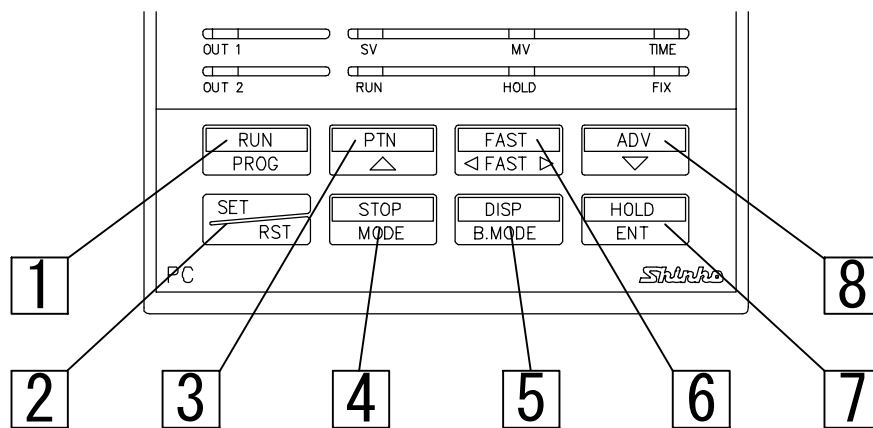

[Fig. 2-1]

- ① **PV display**
It indicates the Process variable (PV) with red display.
- ② **SV/MV/TIME display**
It indicates the Setting value (SV), Manipulating value (MV) or Time (TIME) with green display. (The display can be changed by the  key.)
- ③ **Pattern number display**
It indicates the Pattern number with yellow display.
- ④ **Program monitor indicator**
During program control, green (↗) is lit when the PV is rising.
During program control, green (—) is lit when the PV is constant.
During program control, green (↘) is lit when the PV is falling.
- ⑤ **Step number display**
It indicates the Step number with green display.
- ⑥ **SV indicator [SV]**
Green indicator is lit when the Setting value (SV) is being displayed on the SV/MV/TIME display.
- ⑦ **PC-935, Control output (OUT1) indicator [OUT1]**
Green indicator is lit when the Control output (OUT1) is ON.
(With the current output type, it blinks corresponding to the manipulating value at 0.125 seconds of period.)
- PC-955, Control motor Open output indicator [OUT1]**
Green indicator is lit when the Control motor Open output (OUT1) is ON.

- ⑧ **PC-935, Control output (OUT2) indicator [OUT2]**
Yellow indicator is lit when the Control output (OUT2) is ON.
(With the current output type, it blinks corresponding to the manipulating value at 0.125 seconds of period.)
PC-955, Control motor Closed output indicator [OUT2]
Yellow indicator is lit when the Control motor Closed output (OUT2) is ON.
- ⑨ **Program control performance indicator [RUN]**
During program control, red indicator is lit.
- ⑩ **Alarm 1 output action (including Pattern end 1 output) indicator or Sensor burnout indicator [A1/SB]**
Red indicator is lit when the Alarm 1 (A1) output or Pattern end 1 output is ON.
Red indicator is lit when the Sensor burnout.
- ⑪ **Alarm 2 output action (including Pattern end 2 output) indicator or Loop break alarm output indicator [A2/LA]**
Red indicator is lit when the Alarm 2 (A2) output or Pattern end 2 output is ON.
Red indicator is lit when the Loop break alarm output is ON.
- ⑫ **Alarm 3 output action (including Pattern end 3 output) indicator [A3]**
Red indicator is lit when the Alarm 3 (A3) output or Pattern end 3 output is ON.
- ⑬ **Alarm 4 output action (including Pattern end 4 output) indicator [A4]**
Red indicator is lit when the Alarm 4 (A4) output or Pattern end 4 output is ON.
- ⑭ **Manual control indicator [MAN]**
Red indicator is lit in Manual control.
- ⑮ **Auto-tuning action indicator [AT]**
Decimal point (end of the right) on SV/MV/TIME display blinks during auto-tuning.
- ⑯ **MV indicator [MV]**
Red indicator is lit when the Manipulating value (MV) of the control output (OUT1) is being displayed on the SV/MV/TIME display.
Red indicator blinks when the Manipulating value (MV) of the control output (OUT2) is being displayed on the SV/MV/TIME display.
- ⑰ **Time indicator [TIME]**
Yellow indicator is lit when the Time (TIME) is being displayed on the SV/MV/TIME display.
- ⑱ **Fixed value control mode indicator [FIX]**
Red indicator is lit in Fixed value control.
- ⑲ **Program control hold indicator [HOLD]**
Red indicator blinks when holding program control.



[Fig. 2-2]

- 1**  (Run/Program Key)
- Run key: Starts the Program. Cancels the Hold when holding.
 - Program Key: Changes the mode from Fixed value control to Program control.
In Pattern setting mode, Clears the program.
- 2**  (Set/Reset key)
- Set key: Moves the mode to Setting.
 - Reset key: Returns to Running mode.
- 3**  (Pattern/Up key)
- Pattern key: Selects the Program pattern number.
 - Up key: Increases the value on SV/MV/TIME display or changes the selecting item.
- 4**  (Stop/Mode key)
- Stop key: Stops the program control. Cancels the Pattern end output.
 - Mode key: Changes the Setting mode, and registers the setting data the same as the  key.
- 5**  (Display/Back mode key)
- Display key: Changes the indication on SV/MV/TIME display.
 - Back mode key: Moves each setting mode to the reverse.
- 6**  (Fast key)
- Fast key: During program control, makes step time progress 60 times as fast as usual. Makes the numerical value change faster when setting.
- 7**  (Hold/Entry key)
- Hold key: During program control, holds (halts) the time progress, and controls the process with the setting value at that time.
 - Entry key: Registers the setting data, and moves to the next item.
- 8**  (Advance/Down key)
- Advance key: During program control, interrupts the performing step, and moves the step to the next.
 - Down key: Decreases the value on SV/MV/TIME display or changes the selecting item.

3. Set-up

Taking the internal assembly out

Before the power supplied to this instrument is on, take the internal assembly out from the case by pushing the hook (bottom of the instrument) to arrow direction and holding the notches.

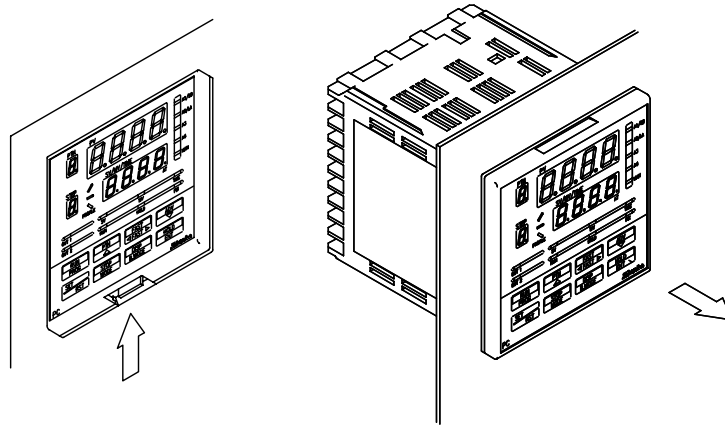

[Fig. 3-1]

Using small slotted screwdriver and tweezers, designate the Sensor input, Alarm 1 action, Alarm 2 action, Control action, Heating (reverse)/Cooling (direct) action, Alarm 1 and 2 standby functions, Unit $^{\circ}\text{C}$ or $^{\circ}\text{F}$ and Program starting form (Automatic/Manual) change by rotary switch and DIP switch by following procedure.

If the option A2 is not applied, the rotary switch A2 (SW301) is not equipped

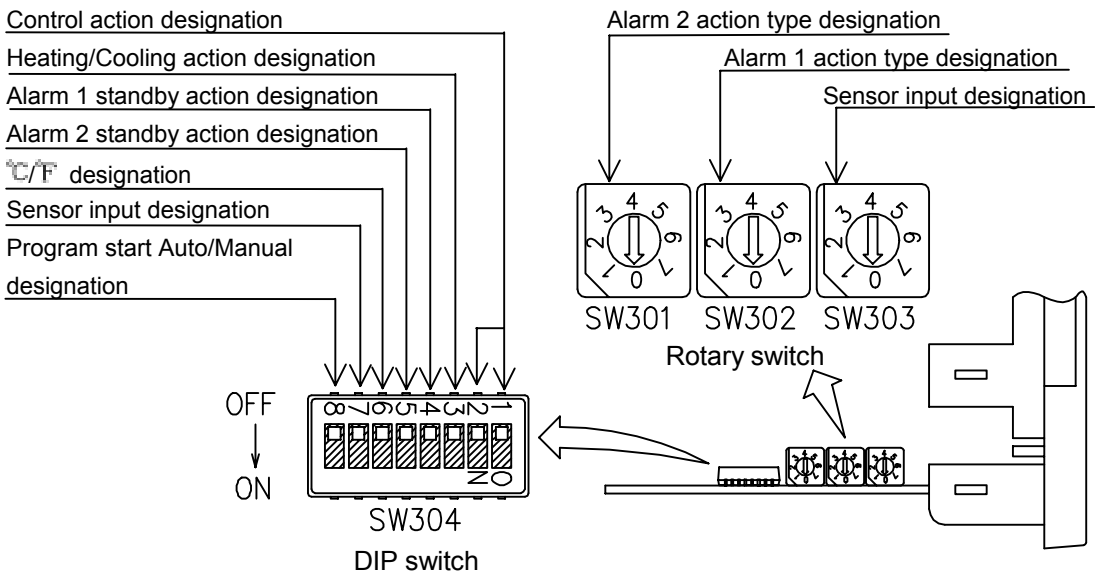

[Fig. 3-2]

- The following items can be designated by the DIP switch (SW304).
Factory adjusted as all switches OFF.

[Table 3-1]

Item	Sw. No.	Designation	Switch Status
Control action	1	PID (with Auto-tuning function)	OFF
		Fuzzy overshoot suppressing PID	ON
Heating/Cooling Action	3	Heating (reverse) action	OFF
		Cooling (direct) action	ON
Alarm 1 standby action	4	No standby action	OFF
		Standby action	ON
Alarm 2 standby action *1	5	No standby action	OFF
		Standby action	ON
°C/°F	6	°C	OFF
		°F	ON
Sensor input *2	7	K, J, R, B, N, PL-II, Pt100, JPt100 (with decimal point)	OFF
		S, E, T, C, 4 to 20mA, 0 to 20mA, 0 to 1V, Pt100 (no decimal point)	ON
Program start Auto/Man	8	Manual start	OFF
		Automatic start	ON

- Make the switch No. 2 of the DIP switch always OFF.

*1: The standby function does not work if the option A2 is not applied.

*2: The sensor input can be designated by the combination of this item and the rotary switch sensor input (SW303).

When starting Program in Program control mode

- Manual start : In case power supplied to the PC-900 is on, it goes to standby mode. Then press the  key to start the program.
- Automatic start : In case power supplied to the PC-900 is on, the program is automatically started from the step 0 directly.

















- The sensor type selection
 Select the sensor by the rotary switch (SW303) and the DIP switch (SW304, No. 7).
 and °C or °F by the DIP switch (SW304, No. 6).
 Factory adjusted as [K, -200 to 1370°C].

[Table 3-2]

SW303 No.	SW304 No.7	Type of sensor	Scale range	
			SW 304 (No. 6 OFF)	SW 304 (NO. 6 ON)
 0	OFF	K	-200 to 1370°C	-320 to 2500°F
 1	OFF	J	-200 to 1000°C	-320 to 1800°F
 2	OFF	R	0 to 1760°C	0 to 3200°F
 3	OFF	B	0 to 1820°C	0 to 3300°F
 4	OFF	PL-II	0 to 1390°C	0 to 2500°F
 5	OFF	N	0 to 1300°C	0 to 2300°F
 6	OFF	Pt100	-199.9 to 850.0°C	-199.9 to 999.9°F
 7	OFF	JPt100	-199.9 to 500.0°C	-199.9 to 900.0°F
 0	ON	S	0 to 1760°C	0 to 3200°F
 1	ON	E	0 to 1000°C	0 to 1800°F
 2	ON	T	-199.9 to 400.0°C	-199.9 to 750.0°F
 3	ON	C(W/Re5-26)	0 to 2315°C	0 to 4200°F
 4	ON	DC 4 to 20mA	-1999 to 9999	
 5	ON	DC 0 to 20mA	-1999 to 9999	
 6	ON	DC 0 to 1V	-1999 to 9999	
 7	ON	Pt100	-200 to 850°C	-320 to 1560°F

- The type of alarm action or the pattern end output for program control can be designated by the rotary switch SW302 (A1) and SW301 (A2)
 If the option A2 is not applied, the rotary switch SW301 (A2) is not equipped.
 Rotary switch SW302 (A1): Alarm 1 (A1) action or Pattern end 1 output.
 Rotary switch SW301 (A2): Alarm 2 (A2) action or Pattern end 2 output.
 Factory adjusted as Alarm 1: Pattern end 1 output
 Alarm 2: No alarm action

[Table 3-3]

Alarm 1 action	Rotary Sw. (SW302) No.	Alarm 2 action	Rotary Sw. (SW301) No.
No alarm action	 0	No alarm action	 0
High limit alarm	 1	High limit alarm	 1
Low limit alarm	 2	Low limit alarm	 2
High/Low limits alarm	 3	High/Low limits alarm	 3
Hi/Lo limit range alarm	 4	Hi/Lo limit range alarm	 4
Process high alarm	 5	Process high alarm	 5
Process low alarm	 6	Process low alarm	 6
Pattern end output	 7	Pattern end output	 7

When the set-up is completed, insert the internal assembly into the case.
 Surely insert the assembly until it is locked by the hook on the bottom of the instrument. (sounds click)
Do not make a mistake about the top and bottom of the internal assembly.
If inserting the assembly into the case by force mistaking the direction, the printed circuit board may be damaged.

4. Mounting to control panel

4.1 Site selection

Mount the controller in a place with:

- (1) A minimum of dust, and an absence of corrosive gases.
- (2) No mechanical vibrations or shocks.
- (3) No exposure to direct sunlight, an ambient temperature is 0 to 50°C (32 to 122°F) and it does not change suddenly.
- (4) An ambient humidity is 85%RH or less, and non-condensing.
- (5) The controller should be away from the electromagnetic switch of large capacity or cables through which large current flows.
- (6) No water, oil nor chemicals and their vapor directly splash.

4.2 External dimension drawing, Panel cutout drawing

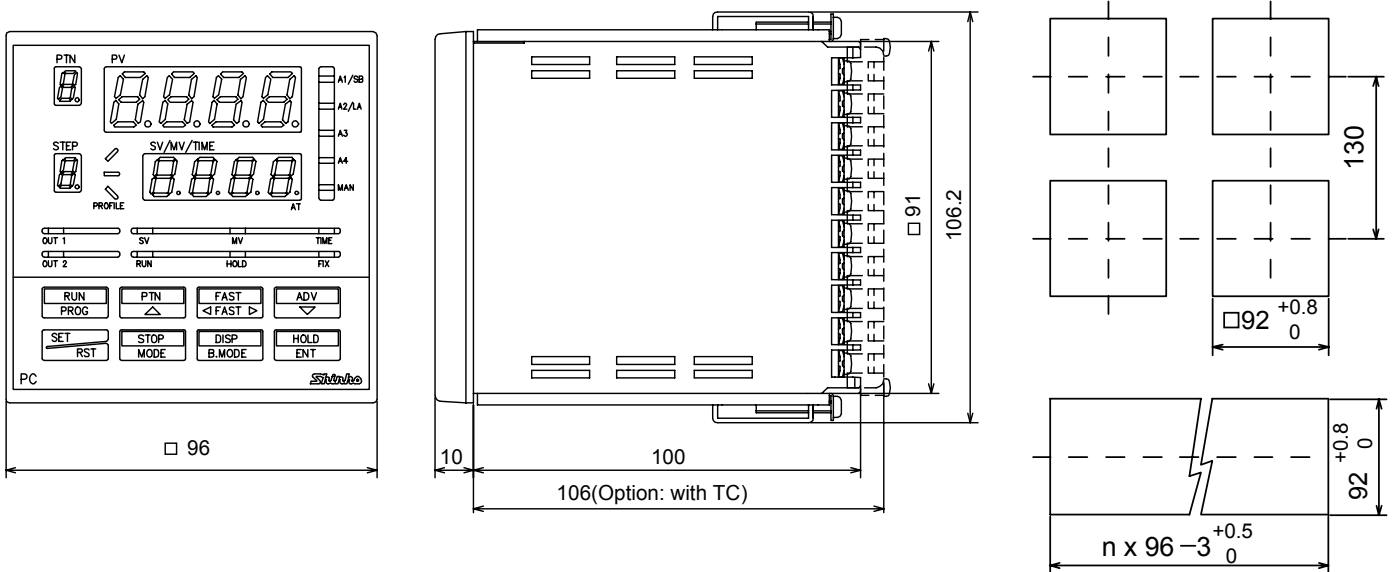

[Fig. 4.2-1]

Lateral close mounting
n: Number of units mounted
 [Fig. 4.2-2]

4.3 Mounting

Mounting panel thickness is 1 to 15mm.

Insert the PC-900 from the front of the panel. Catch the mounting bracket to the holes top and bottom of the case, and screw to fix.

(Do not screw with excessive force, or the case may be bent, because it is made of resin.)

Torque to screw is approximately 0.12N•m.)

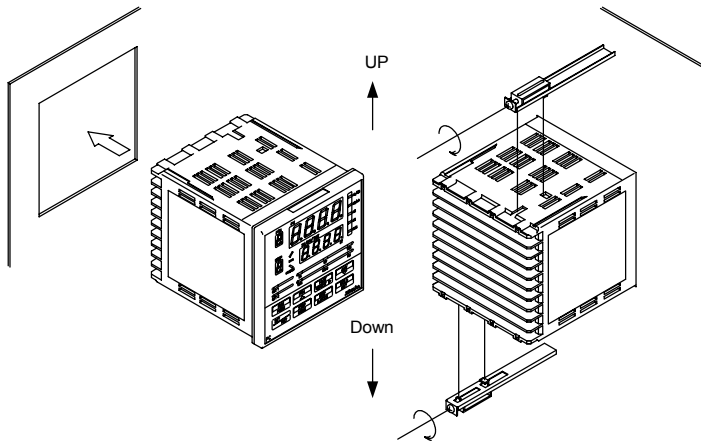

[Fig. 4.3-1]

5. Wiring connection



Warning

Turn the power supplied to the instrument OFF before wiring or checking. If working or touching the terminal on the power ON status, there is a possibility of Electric Shock which can cause severe injury or death. Moreover, the instrument must be grounded before the power supplied to the Instrument is turned on.

5.1 Terminal arrangements

PC-935 type

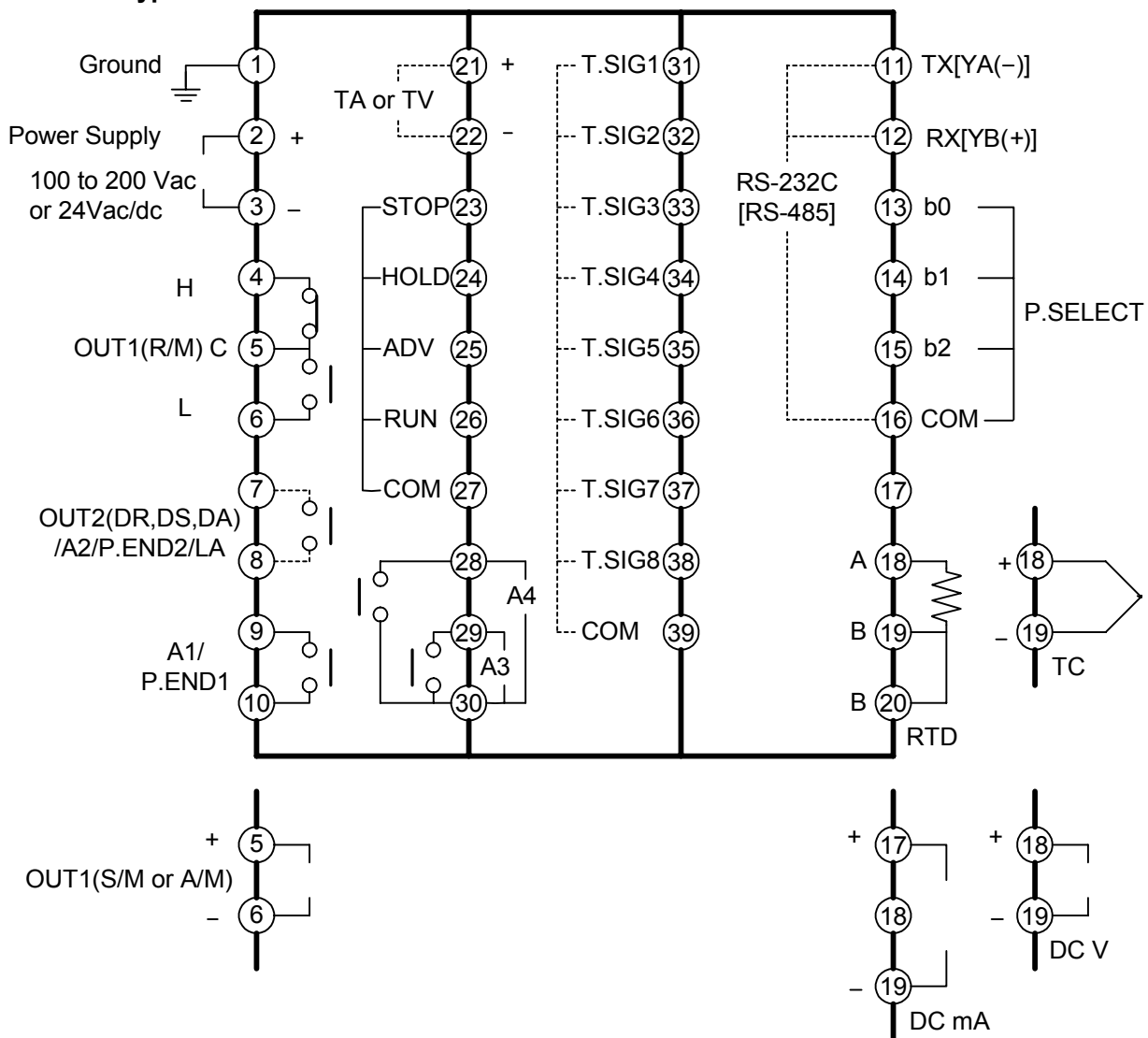

[Fig. 5.1-1]

PC-955 type

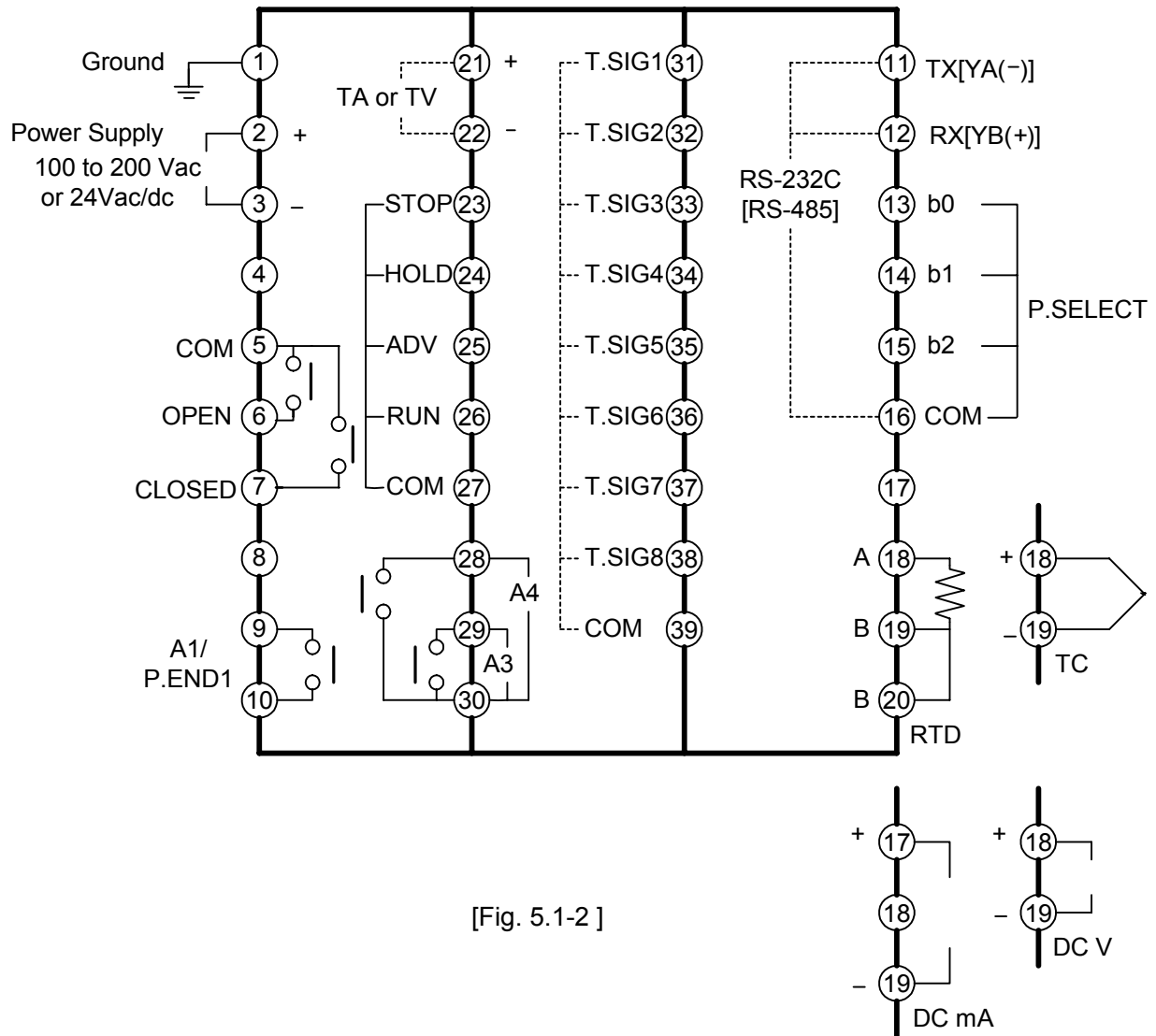

[Fig. 5.1-2]

- The terminal block of this instrument is designed to wire from the left side.
Lead wire must be inserted from the left side of the terminal, and fasten by the terminal screw.
- Dotted line shows the option, no terminal is equipped if it is not specified.

- A1 to A4 : Alarm 1 output to Alarm 4 output (A2: PC-935 type only)
- OUT1, OUT2 : Control output (OUT1), Control output (OUT2) [Heating/Cooling control]
- DR, DS, DA : Heating/Cooling control output(Relay contact, Non-contact voltage, Current)
- TA, TV : Transmission output
- LA : Loop break alarm output (PC-935 type only)
- P. SELECT : Pattern No. external selection
- P. END : Pattern end output
- T.SIG : Time signal output
- STOP, HOLD, ADV, RUN, COM : External operation terminal

● Recommended terminal

Use a solderless terminal with insulation sleeve to fit to M3 screw as shown below.

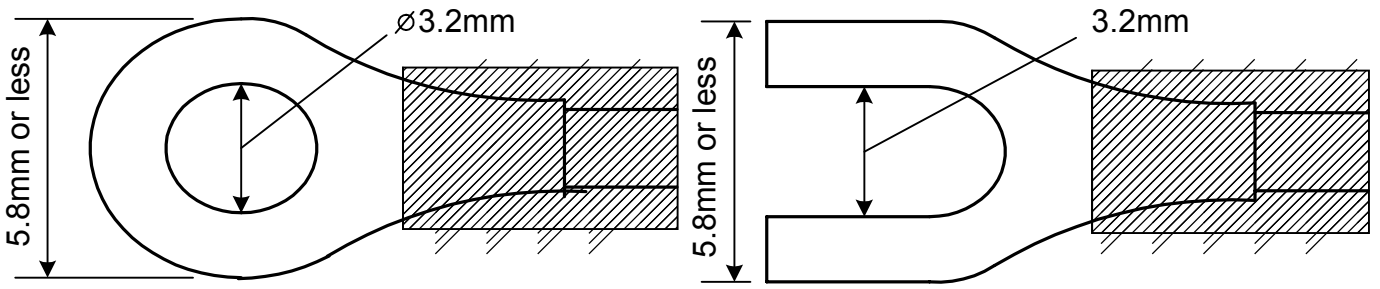

[Fig. 5.1-3]

Solderless terminal	Manufacturer	Model name	Tightening torque
Y type	Nichifu Terminal Industries CO.,LTD.	1.25-Y3	0.6 N•m, Max 1.0 N•m
	Japan Solderless Terminal MFG CO.,LTD.	VD1.25-B3A	
Round type	Nichifu Terminal Industries CO.,LTD.	1.25-3	
	Japan Solderless Terminal MFG CO.,LTD.	V1.25-3	

5.2 Wiring connection examples

**Notice**

Select 3A of fuse from European qualified products, and mount it with the holder in the external circuit within 3m of distance from the controller.

**Notice**

- Use a thermocouple and compensating lead wire applicable to the input specifications of this controller.
- Use a 3-wire system of RTD applicable to the input specifications of this controller.
- This controller has no built-in power switch nor fuse. Therefore, the circuit breaker (conforming to IEC standard, 100Vac 5A, 220Vac 5A) should be provided in the circuit near the external controller, besides should be indicated as the switch used to cut the circuit.
- In case of 24Vdc, do not make a mistake on the polarity.
- With the relay contact output type, use an auxiliary electromagnetic switch externally to protect the built-in relay contact.
- In case of PC-955 type, provide the electromagnetic switch between PC-955 and control motor.
- When wiring, keep input wire (Thermocouple, RTD, etc.) away from AC source and load wire to avoid external interference.
Use a thick wire (1.25 to 2.0mm²) for the earth ground.

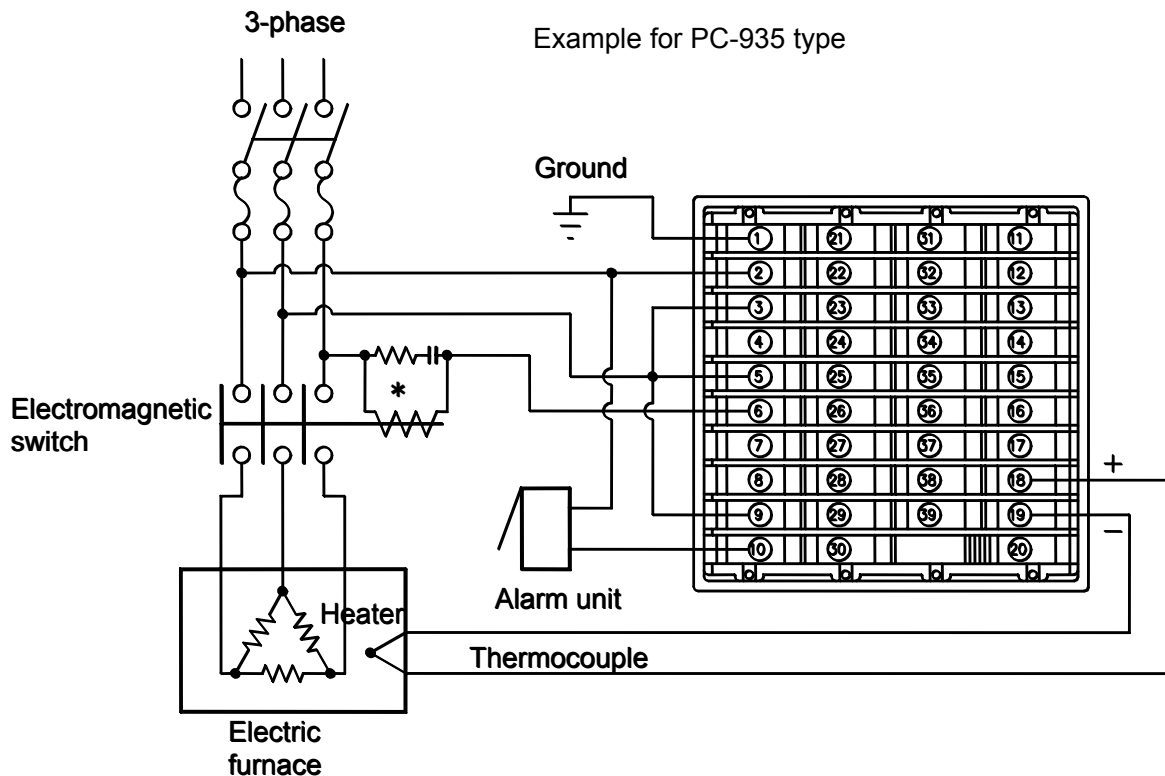

[Fig. 5.2-1]

* To prevent from a bad influence to the instrument owing to the unexpected level noise, it is recommended that the surge absorber be provided between the coil of the external relay.

Example for PC-955 type

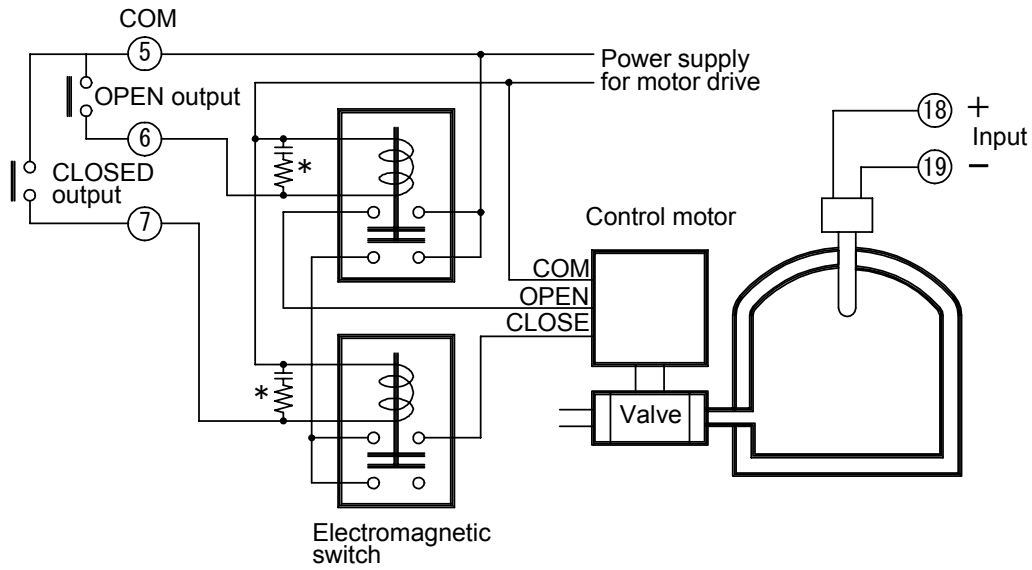

[Fig. 5.2-2]

- External operation input terminal
Open collector input

Contact (pulse) input

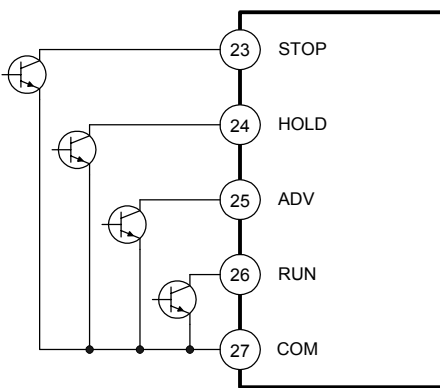

[Fig. 5.2-3]

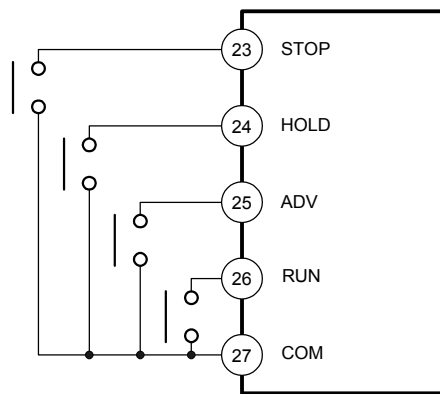

[Fig. 5.2-4]

Pattern number external selection

Time signal output terminal (Option: TS)
Open collector output: 8 circuits
Capacity: 24Vdc 50mA maximum

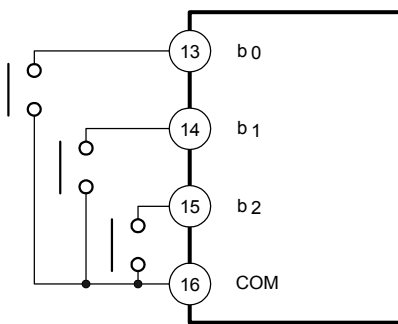

[Fig. 5.2-5]

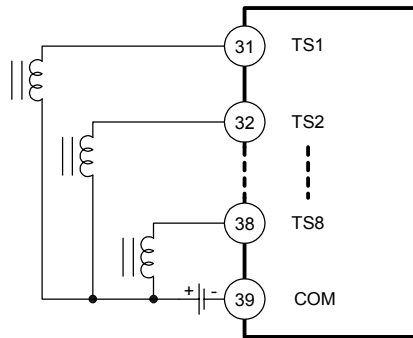

[Fig. 5.2-6]

6. Operation
6.1 Operation flow chart

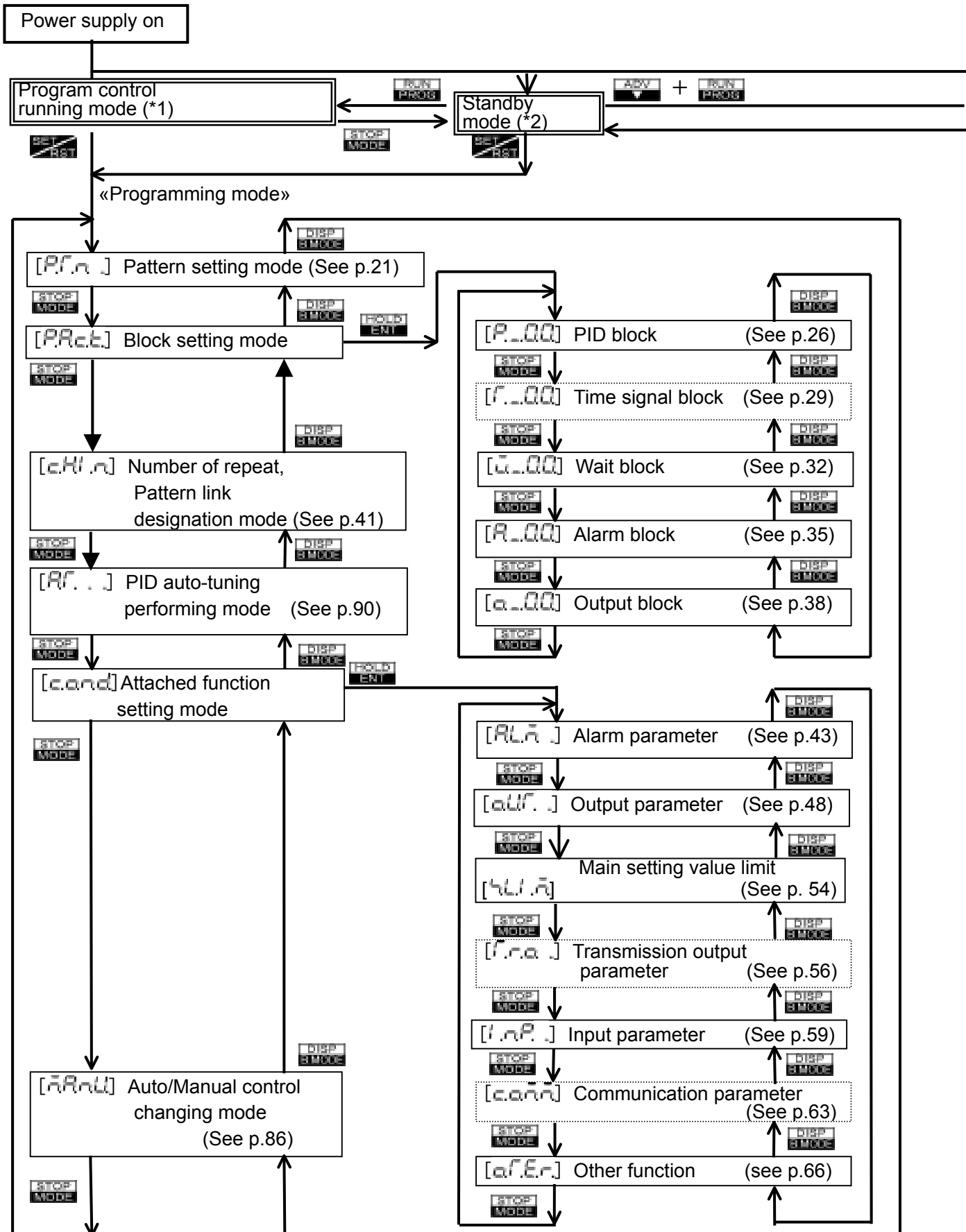

6.2 Key operation when setting

- Press the **PTN** or **ADV** key to change the setting value or the selection.
When the **PTN** and **FAST** key or the **ADV** and **FAST** key pressed simultaneously, makes the numerical value change faster when setting.
- To register the setting value or selected item, use the **STOP MODE** or **HOLD ENT** key.
- To return the mode from each setting mode to Program control running mode, Standby mode or Fixed value control running mode, press the **SET** key.

6.3 Program pattern setting

If the mode is in Fixed value control running mode, press the **RUN PROG** key to select Standby mode.

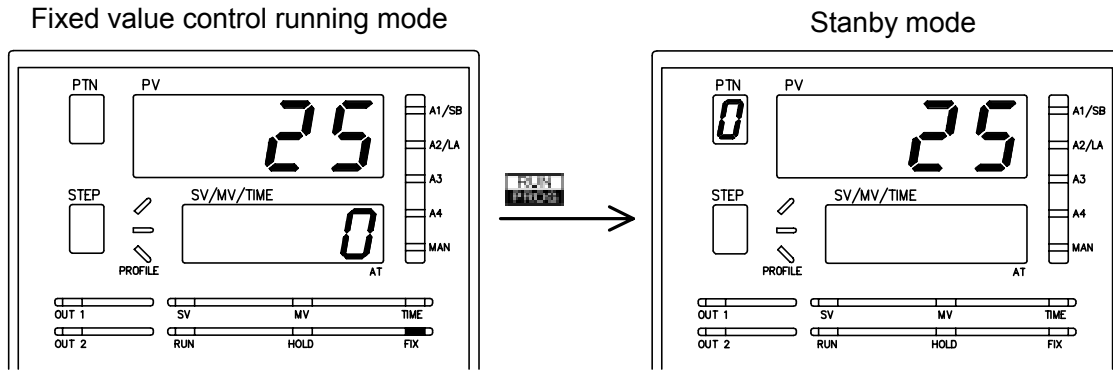

Fixed value control mode indicator (FIX) is lit.

[Fig. 6.3-1]

Fixed value control mode indicator (FIX) is unlit.

[Indications of each display and indicator depend on from the status of the instrument.]

Referring to page 126 (Program pattern graphing example), the setting procedure is shown as follows.

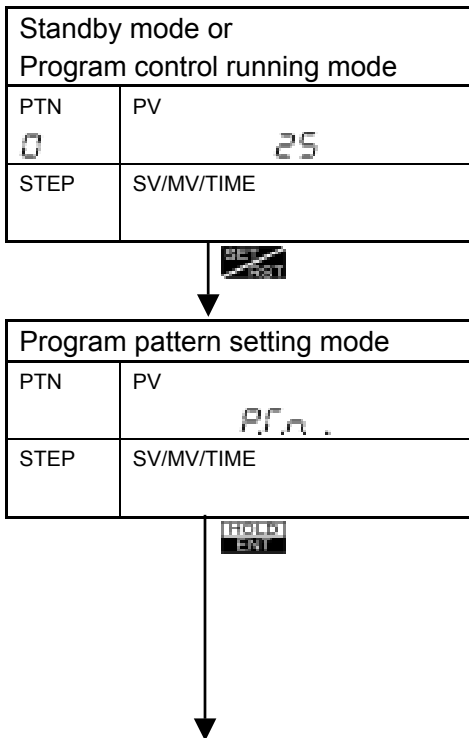

↓

Pattern number selection to be set the Program pattern	
PTN	PV
0	Prn
STEP	SV/MV/TIME
	0

- Selection: 0 to 9
- Factory adjusted as Pattern number 0.

↓

Step temperature setting for Step number 0	
PTN	PV
0	TEMP
STEP	SV/MV/TIME
0	500

- Step temperature setting value is the step end value.
- Setting range: Main setting value low limit to Main setting value high limit
- Factory adjusted as 0°C.

↓

Step time setting for Step number 0	
PTN	PV
0	TIME
STEP	SV/MV/TIME
0	0030

- Step time setting value is the process time of the step
- Setting range: 00.00 to 99.59
(hour: minute, or minute: second)
The unit of time is as selected in Step time unit selection.
- Factory adjusted as 00.00 (hour: minute).

↓

PID block number selection to be used for Step number 0	
PTN	PV
0	_PID
STEP	SV/MV/TIME
0	1

- Selects PID block number to be used.
PID block number is selected from the block, set by PID block data setting.
- Selection: 0 to 9
- Factory adjusted as PID block number 0.

↓

Time signal 1 (TS1) block number selection to be used for Step number 0	
PTN	PV
0	_TS1
STEP	SV/MV/TIME
0	0

- Selects Time signal block number to be used in Time signal 1.
TS1 block number is selected from the block, set by TS block data setting .
- Selection: 0 to 15
- Factory adjusted as TS1 block number 0.
- This item is available only when option Time signal output (TS) is added. When Status output (RUN) is selected by TS1 Time signal output/ Status output (RUN) selection, this item is not available.

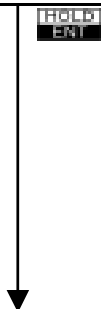

How to select, selection or factory adjusted values of [Time signal (TS2) block number section] to [Time signal (TS8) block number selection] are the same as [Time signal (TS1) block number section], however, they differ in the selecting item below.

Time signal output/Status output (RUN) selection for TS1. (See page 22)

Time signal output/Status output (HOLD) selection for TS2.

Time signal output/Status output (WAIT) selection for TS3.

Time signal output/Status output (FAST) selection for TS4.

Time signal output/Status output (STOP) selection for TS5.

HOLD
ENT

Wait block number selection
to be used for Step number 0

PTN	PV
0	_WAR
STEP	SV/MV/TIME
0	1

- Selects Wait block number to be used.
Wait block number is selected from the block, set by Wait block data setting.
- Selection: 0 to 9
- Factory adjusted as Wait block number 0.

HOLD
ENT

Alarm block number selection
to be used for Step number 0

PTN	PV
0	_ALR
STEP	SV/MV/TIME
0	1

- Selects Alarm block number to be used.
Alarm block number is selected from the block, set by Alarm Block data setting.
- Selection: 0 to 9
- Factory adjusted as Alarm block number 0.

HOLD
ENT

Output block number selection
to be used for Step number 0

PTN	PV
0	_OUR
STEP	SV/MV/TIME
0	0

- Selects Output block number to be used.
Output block number is selected from the block, set by Output Block data setting.
- Selection: 0 to 9
- Factory adjusted as Output block number 0.

HOLD
ENT



Data setting for Step number 0 is completed. The indication on Step display will be changed to # [1], and the item is turned to **Step temperature setting for Step number 1**.



Repeat the operation the same way as **Step temperature setting for Step number 0** to **Output Block number selection to be used for Step number 0** as many steps as necessary.
If the  key is pressed at the item **Output block number selection to be used for Step number 9**, it returns to **Step temperature setting for Step number 0**.



When the setting is completed, press the  key. The mode is returned to **Standby or Program Control running mode**.

6.4 How to clear the setting value

Data on and after any step number in the program pattern can be cleared, besides all setting values can be cleared.

Be careful , if cleared by mistake, the pattern data must be set again.

- **How to clear the program pattern.**

At any item in the program pattern setting mode, press the  key for 3 seconds, and the program pattern data on and after the step number being displayed on the step number display will be cleared and the data returns to factory adjusted values.



«Example»

- **When clearing the program pattern on and after the step number 3 in pattern number 0.**

At any setting item in Step number 3, if the  key is pressed for 3 seconds, the data on and after the Step number 3 to Step number 9 are cleared.

Data of the Step number 0 to Step number 2 in Pattern number 0 and Data of Pattern number 1 to Pattern number 9 are not cleared.

- **How to clear all setting values.**

In standby mode, press the ,  and  keys at the same time for 3 seconds, it returns all setting values excepting the proportional cycle setting value for Control output (OUT1) and (OUT2) to initial value when shipped, and the PV display indicates [c L r].

When the clearing is finished, the display [c L r] goes out and the mode returns to Standby.

6.5 Block data setting

Block setting mode have [PID block], [Time signal block], [Wait block], [Alarm block] and [Output block]. When each block is set, be sure that the mode is Standby mode or Program control running mode.

If the mode is in Fixed value control running mode, press the  key to select Standby mode.

(Refer to [Fig. 6.3-1])

PID block data setting

Referring to page 126 (Program pattern graphing example), the setting procedure is shown as follows.

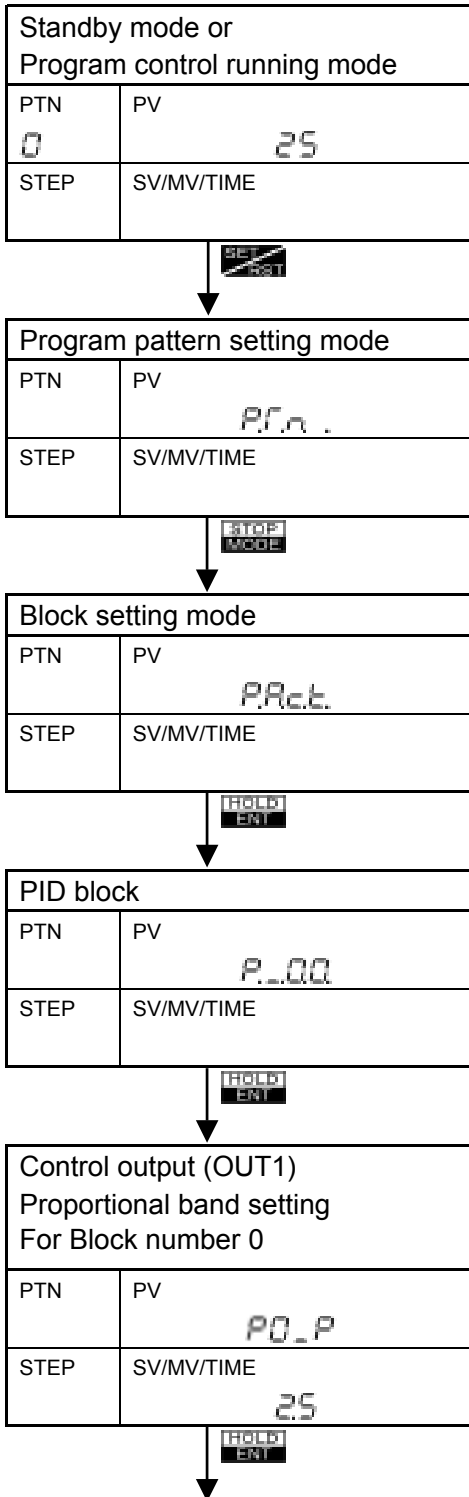

- Set the Control output (OUT1) Proportional band for Block number 0. Setting the value to 0.0 % causes the PC-935 to act as an ON/OFF controller.
- Setting range: 0.0 to 999.9 % (For PC-935 type)
0.1 to 999.9 % (For PC-955 type)
- Factory adjusted as 2.5 %

↓

Integral time setting for Block number 0	
PTN	PV PO_1
STEP	SV/MV/TIME 200

- Set the Integral time for Block number 0.
Setting the value to 0 sec disables the function.
- Setting range: 0 to 3600 sec (For PC-935 type)
1 to 3600 sec (For PC-955 type)
- Factory adjusted as 200 sec

↓

Derivative time setting for Block number 0	
PTN	PV PO_d
STEP	SV/MV/TIME 50

- Set the Derivative time for Block number 0.
Setting the value to 0 sec disables the function.
- Setting range: 0 to 1800 sec
- Factory adjusted as 50 sec

↓

Anti-reset windup setting for Block number 0	
PTN	PV PO_n
STEP	SV/MV/TIME 50

- Set the ARW value for Block number 0.
Setting the value to 0 % disables the function.
- Setting range: 0 to 100 %
- Factory adjusted as 50 %

↓

Control output (OUT2) Proportional band setting for Block number 0	
PTN	PV POPb
STEP	SV/MV/TIME 10

- Set the Control output (OUT2) Proportional band for Block number 0.

Multiplying factor setting to Control output (OUT1) Proportional band. The equation is as follows.

Setting the value to 0.0 causes the PC-900 to act as an ON/OFF controller. If the Proportional band of Control output (OUT1) is 0.0%, it acts as an ON/OFF controller as well.
- Setting range: 0.0 to 10.0 (Multiplying factor)
- Factory adjusted as 1.0
- This setting item is available only when the option Control output (OUT2) [code: DR, DS or DA] is added.
- With the type PC-955, this setting item is not available.

↓

《Equation》

$$\text{Control output (OUT2) Proportional band} = \text{Control output (OUT1) Proportional band} \times \text{Multiplying factor}$$



PID block data setting for Block number 0 is completed. The indication on PV display will be changed to [P1 - P], and the item is turned to **Control output (OUT1) Proportional band setting for Block number 1.**



Repeat the operation the same way as **Control output (OUT1) Proportional band setting for Block number 0** to **Control output (OUT2) Proportional band setting for block number 0** as many blocks as necessary.

If the  key is pressed at the item **Control output (OUT2) Proportional band setting for block number 9**, it returns to **Control output (OUT1) Proportional band setting for Block number 0.**



When the setting is completed, press the  key. The mode is returned to **Standby or Program Control running mode.**

Time signal block data setting

When the option Time signal output [TS] is added, the character Time signal block [r...00] is indicated on the PV display.

Referring to page 126 (Program pattern graphing example), the setting procedure is shown as follows.

Standby mode or Program control running mode	
PTN	PV
0	25
STEP	SV/MV/TIME



Program pattern setting mode	
PTN	PV
	P.P.n.
STEP	SV/MV/TIME



Block setting mode	
PTN	PV
	P.P.ct.
STEP	SV/MV/TIME



PID block	
PTN	PV
	P_00
STEP	SV/MV/TIME



Time signal block	
PTN	PV
	r_00
STEP	SV/MV/TIME



↓

Time signal output OFF time setting for Block number 0	
PTN	PV 00_F
STEP	SV/MV/TIME 0000

- Set the Time signal output OFF time for Block number 0
- Setting range: 00.00 to 99.59
(hours:minutes or minutes:seconds)
The time unit is selected by Step time unit selection.
- Factory adjusted as 00.00 (hours:minutes)

[HOLD]
[ENT]

↓

Time signal output ON time setting for Block number 0	
PTN	PV 00_n
STEP	SV/MV/TIME 0000

- Set the Time signal output ON time for Block number 0
- Setting range: 00.00 to 99.59
(hours:minutes or minutes:seconds)
The time unit is selected by Step time unit selection.
- Factory adjusted as 00.00 (hours:minutes)

[HOLD]
[ENT]

↓

Time signal data setting for Block number 0 is completed. The indication on PV display will be changed to [0 1_F], and the item is turned to **Time signal output OFF time setting for Block number 1**.

↓

Repeat the operation the same way as **Time signal output OFF time setting for Block number 0** to **Time signal output ON time setting for Block number 0** as many blocks as necessary.
If the [HOLD] [ENT] key is pressed at the item **Time signal output ON time setting for Block number 15**, it returns to **Time signal output OFF time setting for Block number 0**.

↓

When the setting is completed, press the [HOLD] [ENT] key. The mode is returned to **Standby or Program Control running mode**.

The function of Time signal

Time signal is a function to provide Time signal outputs for each step during program control by setting the output OFF time and ON time.

- Maximum 8 Time signal outputs can be set for each step number.
- Time signal output works in order Output OFF time and Output ON time.
The signal automatically turns OFF when ON time expires within a step.
- Combination of Output OFF time and Output ON time as one block, up to 16 blocks can be set.
- When the ON time is set the same as the Step time, the Time signal output turns a momentary OFF condition at the turning point of the step. When a Time signal ON time is meant to continue to the next step, set the ON time so that it can extend into the next step.
- When moved to the next step, the Time signal output acts OFF/ON following the step setting no relation to the previous step.

Wait block data setting

Referring to page 126 (Program pattern graphing example), the setting procedure is shown as follows.

Standby mode or Program control running mode	
PTN	PV
0	25
STEP	SV/MV/TIME



Program pattern setting mode	
PTN	PV
	P.F.n .
STEP	SV/MV/TIME



Block setting mode	
PTN	PV
	P.R.ct.
STEP	SV/MV/TIME



PID block	
PTN	PV
	P.00
STEP	SV/MV/TIME



Press the **STOP MODE** key several times until the Wait block character [0.00] is Indicated on PV display. If passed, use the **HOLD ENT** key.

Wait block	
PTN	PV
	0.00
STEP	SV/MV/TIME



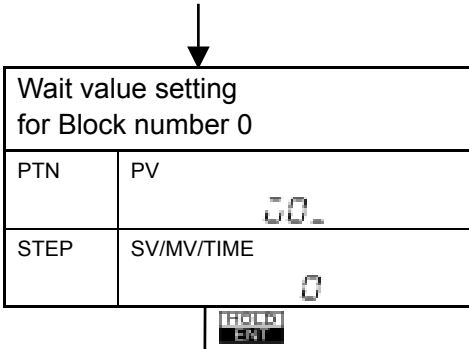

- Set the Wait value for Block number 0.
- Setting range: 0 to 100°C(F)
 In case of T type of thermocouple or decimal point applied RTD, 0.0 to 100.0°C(F)
 In case of DC input, 0 to 1000
 The decimal point place is the same as the selected place.
- Factory adjusted as 0°C

Wait value setting for Block number 0 is completed. The indication on PV display will be changed to [0 1.], and the item is turned to **Wait value setting for Block number 1**.

Repeat the operation the same way as **Wait value setting for Block number 0** as many blocks as necessary. If the **HOLD/ENT** key is pressed at the item **Wait value setting for Block number 9**, it returns to **Wait value setting for Block number 0**.

When the setting is completed, press the **SET** key. The mode is returned to **Standby or Program Control running mode**.

Wait function

A function during program control, it does not proceed to the next step at the end of the step until the PV (process variable) reaches within the Waiting zone [SV (setting value) to $SV \pm$ Wait value]. The progress of the step time is suspended at that time.

The step number display blinks during the Wait action.

The Wait function works when

« $SV - \text{Wait value} \leq PV \leq SV + \text{Wait value}$ »

- In case the program pattern is rising

« $SV - \text{Wait value} \leq PV$ »

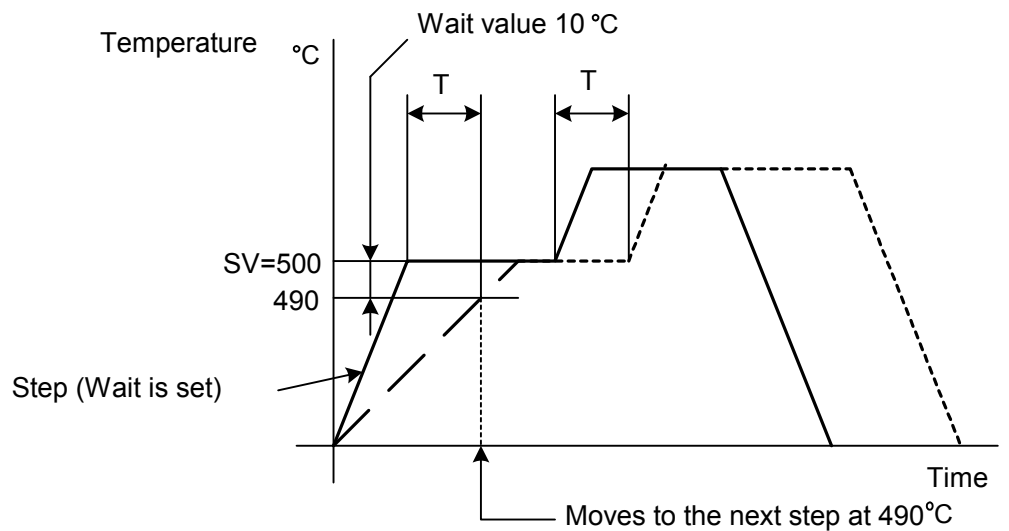

[Fig. 6.5-2]

- In case the program pattern is falling

« $SV + \text{Wait value} \geq PV$ »

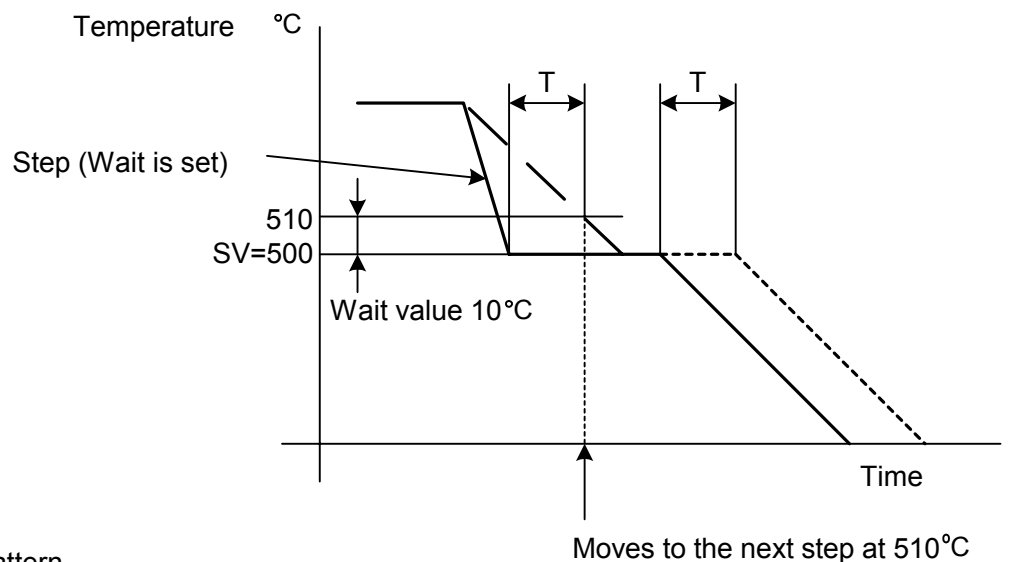

- Program pattern
- - - - - Process variable
- - - - - Program pattern T time delayed by wait time

[Fig. 6.5-3]

Wait function cancellation

Wait function can be canceled by pressing the **ADV** or **STOP MODE** key.

[ADV] or [STOP] input of the External operation function can be canceled the Wait function as well.

Alarm block data setting

Referring to page 126 (Program pattern graphing example), the setting procedure is shown as follows.

Standby mode or Program control running mode	
PTN	PV
0	25
STEP	SV/MV/TIME



Program pattern setting mode	
PTN	PV
	P.F.n.
STEP	SV/MV/TIME



Block setting mode	
PTN	PV
	P.R.ct.
STEP	SV/MV/TIME



PID block	
PTN	PV
	P._00
STEP	SV/MV/TIME



Press the **STOP MODE** key several times until the Alarm block character [A_00] is indicated on PV display.
If passed, use the **STOP MODE** key.

Alarm block	
PTN	PV
	A_00
STEP	SV/MV/TIME



Alarm 1 (A1) action point setting for Block number 0

PTN	PV
	AO_1
STEP	SV/MV/TIME
	0

↑ HOLD
↓ ENT

Alarm 2 (A2) action point setting for Block number 0

PTN	PV
	AO_2
STEP	SV/MV/TIME
	1 370

↑ HOLD
↓ ENT

Alarm 3 (A3) action point setting for Block number 0

PTN	PV
	AO_3
STEP	SV/MV/TIME
	0

↑ HOLD
↓ ENT

Alarm 4 (A4) action point setting for Block number 0

PTN	PV
	AO_4
STEP	SV/MV/TIME
	0

↑ HOLD
↓ ENT

- Set the Alarm 1 (A1) action point for Block number 0.
- This item is not available when Pattern end output 1 is selected (initial status), and if no alarm action is selected by rotary switch (SW302).
- When using the Alarm 1 (A1) as alarm action, select Alarm 1 action by rotary switch SW302 (A1).
- Setting range: See the table on the next page.
- Factory adjusted as Pattern end output 1

- Set the Alarm 2 (A2) action point for Block number 0.
- This item is not available to following cases.
 - (1) Option A2 is not applied.
 - (2) No alarm action or Pattern end output 2 is selected by rotary switch (SW301).
 - (3) For the type PC-955.
- Setting range: See the table on the next page.
- Factory adjusted as 0℃

- Set the Alarm 3 (A3) action point for Block number 0.
- This item is not available when No alarm action or Pattern end output 3 is selected by key operation in Alarm 3 (A3) action form selection.
- Setting range: See the table on the next page.
- Factory adjusted as 0℃

- Set the Alarm 4 (A4) action point for Block number 0.
- This item is not available when No alarm action or Pattern end output 4 is selected by key operation in Alarm 4 (A4) action form selection.
- Setting range: See the table on the next page.
- Factory adjusted as 0℃

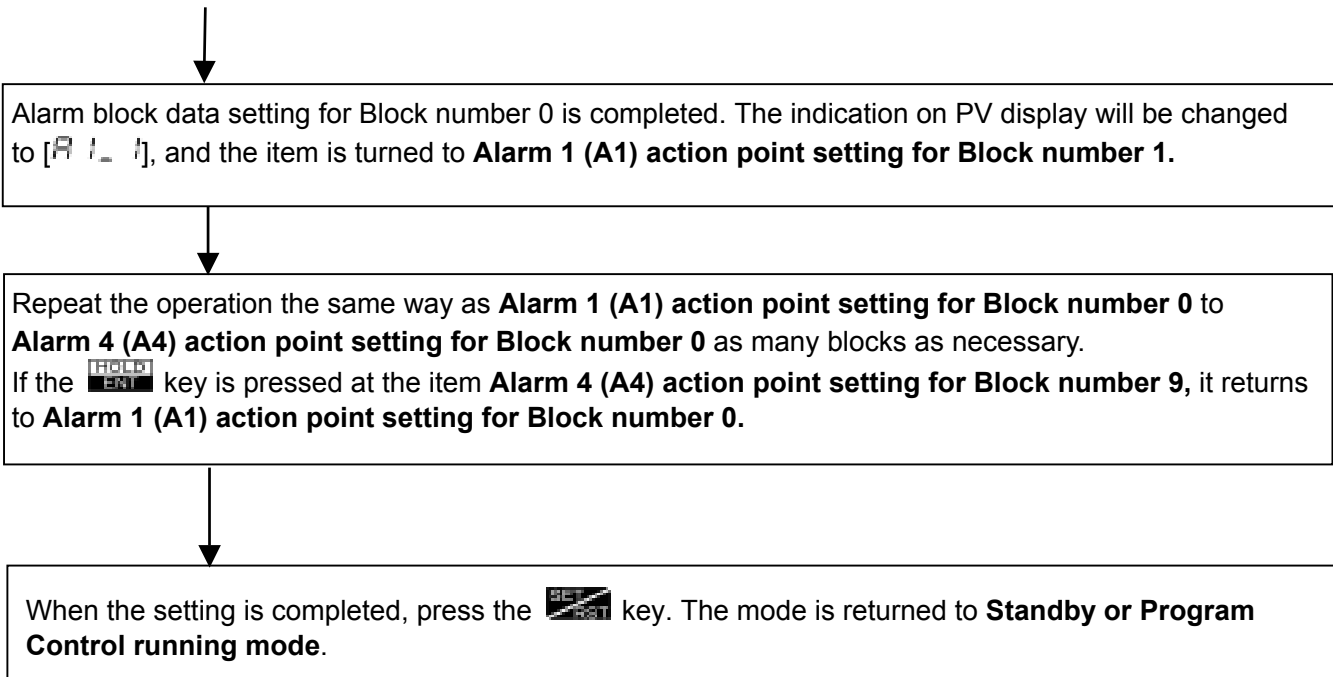

● Alarm 1 to Alarm 4 setting range (The same range is applicable when Standby function is applied.)

[Table 6.5-1]

Type of alarm	Setting range	Setting range (with decimal point)
High limit alarm (*)	-Input range span to Input range span	-199.9 to Input range span
Low limit alarm (*)	-Input range span to Input range span	-199.9 to Input range span
High/Low limits alarm (*)	0 to Input range span	0.0 to Input range span
High/Low limit range alarm (*)	0 to Input range span	0.0 to Input range span
Process high alarm	Input range minimum value to Input range maximum value	-199.9 to Input range maximum value
Process low alarm	Input range minimum value to Input range maximum value	-199.9 to Input range maximum value

(*): Deviation setting

- When the input type is DC, for [Input range span] read [Input range scaling span], the minimum value of minus side is -1999. (The decimal point place follows the selection.)
- In case the input type is RTD with decimal point or T type of thermocouple, the minimum value of minus side is -199.9.

Output block data setting

Referring to page 126 (Program pattern graphing example), the setting procedure is shown as follows.

Standby mode or Program control running mode	
PTN	PV
0	25
STEP	SV/MV/TIME



Program pattern setting mode	
PTN	PV
	P.F.n.
STEP	SV/MV/TIME



Block setting mode	
PTN	PV
	P.R.ct.
STEP	SV/MV/TIME



PID block	
PTN	PV
	P.00
STEP	SV/MV/TIME



Press the **STOP/MODE** key several times until the Output block character [a.00] is indicated on PV display. If passed, use the **STOP/MODE** key.

Output block	
PTN	PV
	a.00
STEP	SV/MV/TIME



Control output (OUT1) high limit
Setting for Block number 0

PTN	PV
	00_H
STEP	SV/MV/TIME
	100

[HOLD] [ENT]

- Set the Control output (OUT1) high limit for Block number 0.
- Setting range: Control output (OUT1) low limit setting value to 105%
Setting more than 100% is effective only to DC current output type.
- Factory adjusted as 100%.

Control output (OUT1) low limit
Setting for Block number 0

PTN	PV
	00_L
STEP	SV/MV/TIME
	0

[HOLD] [ENT]

- Set the Control output (OUT1) low limit for Block number 0.
- Setting range: -5% to Control output (OUT1) high limit setting value
Setting less than 0% is effective only to DC current output type.
- Factory adjusted as 0%.

Control output (OUT2) high limit
Setting for Block number 0

PTN	PV
	00Hb
STEP	SV/MV/TIME
	100

[HOLD] [ENT]

- Set the Control output (OUT2) high limit for Block number 0.
- This setting item is available only when the option Control output (OUT2 [code: DR, DS, DA]) is applied.
- With the PC-955 type, this item is not available.
- Setting range: Control output (OUT2) low limit setting value to 105%
Setting more than 100% is effective only to DC current output type [code: DA].
- Factory adjusted as 100%.

Control output (OUT2) low limit
Setting for Block number 0

PTN	PV
	00Lb
STEP	SV/MV/TIME
	0

[HOLD] [ENT]

- Set the Control output (OUT2) low limit for Block number 0.
- This setting item is available only when the option Control output (OUT2 [code: DR, DS, DA]) is applied.
- With the PC-955 type, this item is not available.
- Setting range: -5% to Control output (OUT2) high limit setting value
Setting less than 0% is effective only to DC current output type [code: DA].
- Factory adjusted as 0%.

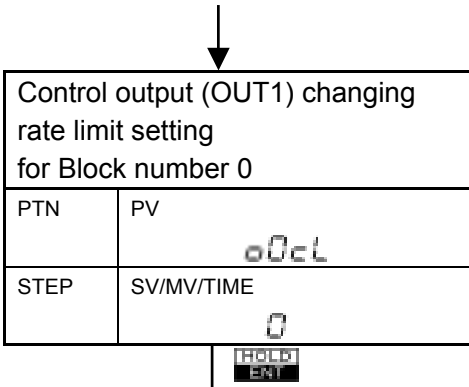

- Set the Control output (OUT1) changing rate limit for Block number 0. Setting the value to 0%/sec. disables the function.
- Setting range: 0 to 100%/sec.
- Factory adjusted as 0%/sec.

↓

Output block data setting for Block number 0 is completed. The indication on PV display will be changed to [o L H], and the item is turned to **Control output (OUT1) high limit setting for Block number 1.**

↓

Repeat the operation the same way as **Control output (OUT1) high limit setting for Block number** to **Control output (OUT1) changing rate limit setting for Block number 0** as many blocks as necessary. If the  key is pressed at the item **Control output (OUT1) changing rate limit setting for Block number 9**, it returns to **Control output (OUT1) high limit setting for Block number 0.**

↓

When the setting is completed, press the  key. The mode is returned to **Standby or Program Control running mode.**

6.6 Number of Repeat of the Pattern and Pattern link setting

If the mode is in Fixed value control running mode, press the **STOP MODE** key to select Standby mode.

Fixed value control running mode

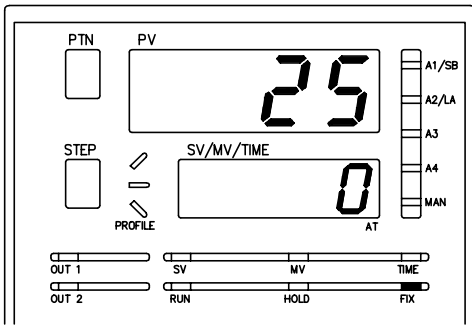

Fixed value control mode indicator (FIX) is lit.



Standby mode

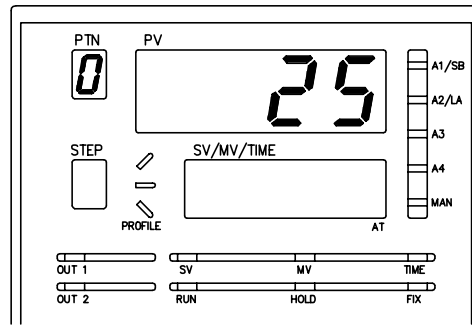

Fixed value control mode indicator (FIX) is unlit.

[Fig. 6.6-1]

[Indications of each display and indicator depend on the status of the instrument.]

Referring to page 126 (Program pattern graphing example), the setting procedure is shown as follows.

Standby mode or Program control running mode	
PTN	PV
0	25
STEP	SV/MV/TIME



Program pattern setting mode	
PTN	PV
	Pf.n.
STEP	SV/MV/TIME



Number of Repeat and Pattern link designation mode	
PTN	PV
	c.Hi.n
STEP	SV/MV/TIME



Press the **STOP MODE** key several times until the character [c.Hi.n] is indicated on PV display. If passed, use the **DISP MODE** key.

↓

Number of Repeat for Pattern number 0 setting	
PTN	PV
0	rEPF
STEP	SV/MV/TIME
	0

[HOLD] [ENT]

- Set the Number of Repeat for Pattern number 0.
- Setting range: 0 to 9999 times
- Factory adjusted as 0 times

↓

Pattern link selection between Pattern number 0 and 1	
PTN	PV
0	CH n
STEP	SV/MV/TIME

[HOLD] [ENT]

- Select whether to link the program between Pattern number 0 and 1.
- SV/MV/TIME display shows as below

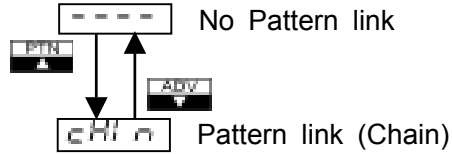

- Factory adjusted as No Pattern link

↓

Setting for Pattern number 0 is completed. The indication on PTN display will be changed to [1], and the item is turned to **Number of Repeat setting for Pattern number 1.**

↓

Repeat the operation the same way as **Number of Repeat for Pattern number 0 setting** to **Pattern link selection between Pattern number 0 and 1** as many patterns as necessary.
 If the [HOLD] [ENT] key is pressed at the item **Pattern link selection between Pattern number 9 and 0**, it returns to **Number of Repeat for Pattern number 0 setting.**

↓

When the setting is completed, press the [SET] key. The mode is returned to **Standby or Program Control running mode.**

6.7 Attached function setting

Set each parameter for Alarm, Output, Main setting value limit, Transmission output, Input, Communication, and Other functions to meet the need of operations.

Alarm parameter setting

The alarm parameter setting items of **Program control running mode** are the same as those of **Fixed value control running mode**.

This section describes how to set the alarm parameters in the **Program control running mode**.

Standby mode or Program control running mode	
PTN	PV
0	25
STEP	SV/MV/TIME



Program pattern setting mode	
PTN	PV
	P.F. n .
STEP	SV/MV/TIME



Attached function setting mode	
PTN	PV
	c.ond
STEP	SV/MV/TIME



Alarm parameter setting	
PTN	PV
	AL. n .
STEP	SV/MV/TIME



- In case of Fixed value control parameter setting mode, the character [F. n .] is indicated on the PV display.

Press the key several times until the character Attached function setting mode [c.ond] is indicated on the PV display. If passed, press the key.

↓

Alarm 3 (A3) action form selection	
PTN	PV AL3F
STEP	SV/MV/TIME H

- Select the Alarm 3 (A3) action form.
- Setting item: See below chart.
- Factory adjusted as High limit alarm.

HOLD
EXIT

SV/MV/TIME display indicates as follows.

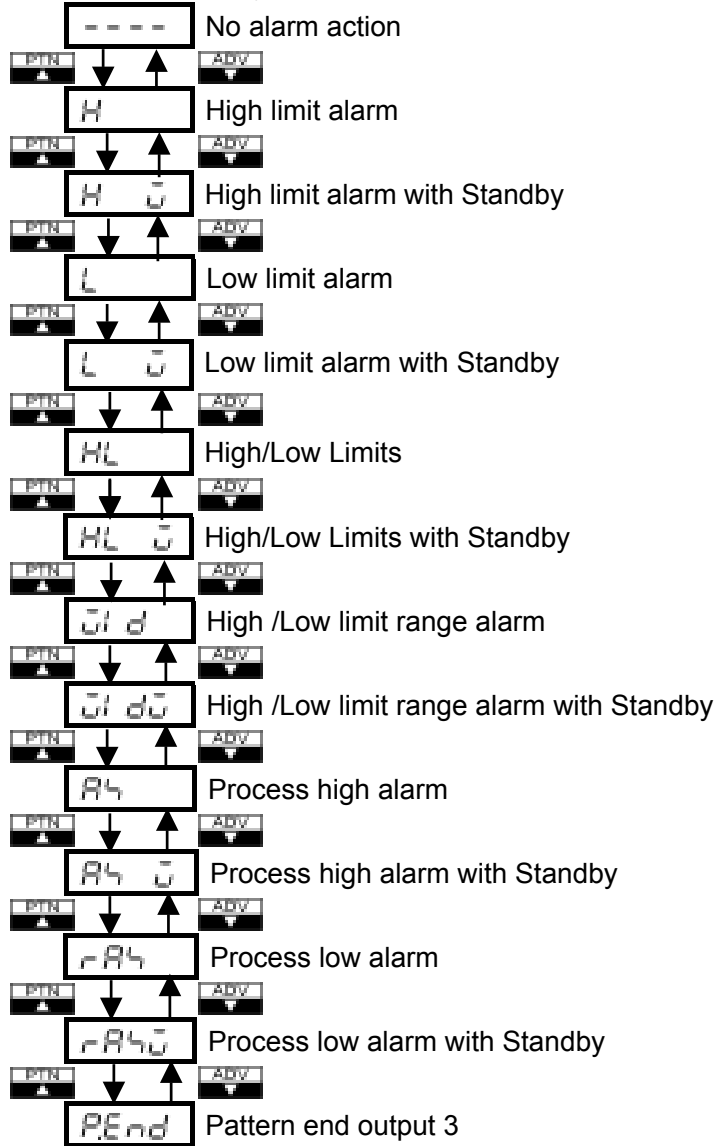

↓

Alarm 4 (A4) action form selection	
PTN	PV AL4F
STEP	SV/MV/TIME L

- Select the Alarm 4 (A4) action form.
- Selecting item: The same as the Alarm 3 (A3) action form selection.
- Factory adjusted as Low limit alarm.

↓

Alarm 1 (A1) hysteresis setting	
PTN	PV A1HY
STEP	SV/MV/TIME 10

- Set the Alarm 1 (A1) hysteresis.
- Setting range: 0.1 to 100.0°C(F)
- Factory adjusted as 1.0°C.
- This item is not available when Pattern end output 1 is selected (initial status), and if no alarm action is selected by rotary switch SW302.

↓

Alarm 2 (A2) hysteresis setting	
PTN	PV A2HY
STEP	SV/MV/TIME 10

- Set the Alarm 2 (A2) hysteresis.
- Setting range: 0.1 to 100.0°C(F)
- Factory adjusted as 1.0°C
- This item is not available to following cases.
 - (1) Option A2 is not applied.
 - (2) No alarm action or Pattern end output 2 is selected by rotary switch (SW301).
 - (3) For the type PC-955.

↓

Alarm 3 (A3) hysteresis setting	
PTN	PV A3HY
STEP	SV/MV/TIME 10

- Set the Alarm 3 (A3) hysteresis.
- Setting range: 0.1 to 100.0°C(F)
- Factory adjusted as 1.0°C
- This item is not available when No alarm action or Pattern end output 3 is selected by key operation in Alarm 3 (A3) action form selection (See page 44).

↓

Alarm 4 (A4) hysteresis setting	
PTN	PV A4HY
STEP	SV/MV/TIME 10

- Set the Alarm 4 (A4) hysteresis.
- Setting range: 0.1 to 100.0°C(F)
- Factory adjusted as 1.0°C
- This item is not available when No alarm action or Pattern end output 4 is selected by key operation in Alarm 4 (A4) action form selection.

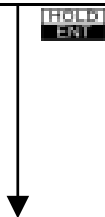

↓

Alarm 1 (A1) delayed timer setting	
PTN	PV A1dy
STEP	SV/MV/TIME 0

HOLD
ENT

↓

Alarm 2 (A2) delayed timer setting	
PTN	PV A2dy
STEP	SV/MV/TIME 0

HOLD
ENT

↓

Alarm 3 (A3) delayed timer setting	
PTN	PV A3dy
STEP	SV/MV/TIME 0

HOLD
ENT

↓

Alarm 4 (A4) delayed timer setting	
PTN	PV A4dy
STEP	SV/MV/TIME 0

HOLD
ENT

↓

- Set the Alarm 1 (A1) delayed timer.
Alarm output turns ON when passed the setting time after the input value (PV) enters the Alarm output range.
- Setting range: 0 to 9999 seconds
- Factory adjusted as 0 seconds
- This item is not available when Pattern end output 1 is selected (initial status), and if No alarm action is selected by rotary switch (SW302).
- Set the Alarm 2 (A2) delayed timer.
Alarm output turns ON when passed the setting time after the input value (PV) enters the Alarm output range.
- Setting range: 0 to 9999 seconds
- Factory adjusted as 0 seconds
- This item is not available to following cases.
 - (1) Option A2 is not applied.
 - (2) No alarm action or Pattern end output 2 is selected by rotary switch (SW301).
 - (3) For the type PC-955.
- Set the Alarm 3 (A3) delayed timer.
Alarm output turns ON when passed the setting time after the input value (PV) enters the Alarm output range.
- Setting range: 0 to 9999 seconds
- Factory adjusted as 0 seconds
- This item is not available when No alarm action or Pattern end output 3 is selected by key operation in Alarm 3 (A3) action form selection (See page 44).
- Set the Alarm 4 (A4) delayed timer.
Alarm output turns ON when passed the setting time after the input value (PV) enters the Alarm output range.
- Setting range: 0 to 9999 seconds
- Factory adjusted as 0 seconds
- This item is not available when No alarm action or Pattern end output 4 is selected by key operation in Alarm 4 (A4) action form selection.

↓

Loop break alarm time setting	
PTN	PV LP_L
STEP	SV/MV/TIME 0

[HOLD] [ENT]

- Set the judgment time for the Loop break alarm.
- Setting range: 0 to 200 minutes
- Factory adjusted as 0 minutes
- This item is not available when the option Loop break alarm is not applied, and for the type PC-955.

↓

Loop break alarm span setting	
PTN	PV LP_H
STEP	SV/MV/TIME 0

[HOLD] [ENT]

- Set the judgment span for the Loop break alarm.
- Setting range: 0 to 100°C(F)
In case of T type of thermocouple, or RTD applied the decimal point, 0.0 to 100.0°C(F)
When the input type is DC, 0 to 1000 (with the DC type, the decimal point place follows the selection. [See page 61])
- Factory adjusted as 0°C
- This item is not available when the option Loop break alarm is not applied, and for the type PC-955.

↓

Setting for Alarm parameter is completed, and the item is turned to **Alarm 3 (A3) action form selection.**

↓

When the setting is completed, press the [RET] key. The mode is returned to Standby or Program control running mode.

● Loop break alarm

- The alarm output turns ON when the process variable (PV) does not rise [fall *] as much value as the span or greater within the time to judge for loop break alarm after the manipulating value reaches to 100% or output high limit value.
- The alarm output also turns ON when the process variable (PV) does not fall [rise *] as much value as the span or greater within the time to judge for loop break alarm after the manipulating value reaches to 0% or output low limit value.
- In case the control output is Direct mode (Cooling), the condition is changed to [*].

Output parameter setting

The output parameter setting items of **Program control running mode** are the same as those of **Fixed value control running mode**. However, [Control output (OUT1) high limit setting], [Control output (OUT1) low limit setting], [Control output (OUT1) changing rate limit setting], [Control output (OUT2) high limit setting] and [Control output (OUT2) low limit setting] used in Fixed value control are not indicated when Program control mode.

This section describes how to set the output parameter in the **Program control running mode**.

Standby mode or Program control running mode	
PTN	PV
0	25
STEP	SV/MV/TIME



Program pattern setting mode	
PTN	PV
	P.F.V.
STEP	SV/MV/TIME



Attached function setting mode	
PTN	PV
	cond
STEP	SV/MV/TIME



Alarm parameter setting	
PTN	PV
	AL.A.
STEP	SV/MV/TIME

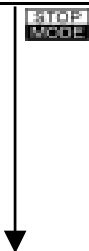

- In case of Fixed value control parameter setting mode, the character [F.V.] is indicated on the PV display.

Press the **STOP MODE** key several times until the character Attached function setting mode [cond] is indicated on the PV display. If passed, press the **HOLD/ENT** key.

↓

Output parameter setting	
PTN	PV OUT
STEP	SV/MV/TIME

[HOLD]
[ENT]

Control output (OUT1) proportional cycle setting	
PTN	PV C
STEP	SV/MV/TIME 30

[HOLD]
[ENT]

Control output (OUT1) high limit setting	
PTN	PV oLH
STEP	SV/MV/TIME 100

[HOLD]
[ENT]

Control output (OUT1) low limit setting	
PTN	PV oLL
STEP	SV/MV/TIME 0

[HOLD]
[ENT]

↓

- Set the Control output (OUT1) proportional cycle.
- Setting range: 1 to 120 seconds
- Factory adjusted as
30 seconds for the type Relay contact output
3 seconds for the type Non-contact voltage output
- In case of PC-955, this setting item is for the manipulating value operating cycle, and it controls by operating the manipulating value every fixed time.
- This setting item is not available to the type DC current output.
- Set the Control output (OUT1) high limit.
- Setting range: Control output (OUT1) low limit setting value to 105%
Setting more than 100% is effective only to DC current output type.
- Factory adjusted as 100%.
- This setting item is available only to Fixed value control parameter setting mode.
- Set the Control output (OUT1) low limit.
- Setting range: -5% to Control output (OUT1) high limit setting value
Setting less than 0% is effective only to DC current output type.
- Factory adjusted as 0%.
- This setting item is available only to Fixed value control parameter setting mode.

↓

Control output (OUT1) ON/OFF hysteresis setting	
PTN	PV HYH
STEP	SV/MV/TIME 10

- Set the Control output (OUT1) ON/OFF hysteresis.
- Setting range: 0.1 to 100.0°C(F)
- Factory adjusted as 1.0°C
- This setting item is not available to the type PC-955.

[HOLD] [ENT]

↓

Control output (OUT1) changing rate limit setting	
PTN	PV orRf
STEP	SV/MV/TIME 0

- Set the Control output (OUT1) changing rate limit.
- Setting range: 0 to 100.0%/sec
- Factory adjusted as 0%/sec
- This setting item is available only to Fixed value control parameter setting mode.

[HOLD] [ENT]

↓

Control output (OUT2) proportional cycle setting	
PTN	PV c_b
STEP	SV/MV/TIME 30

- Set the Control output (OUT2) proportional cycle.
- Setting range: 1 to 120 seconds
- Factory adjusted as
30 seconds for the type Relay contact output
3 seconds for the type Non-contact voltage out
- This setting item is available only when the option [DR or DS] is added.
- With the type PC-955, this setting item is not available.
- This setting item is not available to the type DC current output [DA].

[HOLD] [ENT]

↓

Control output (OUT2) action selection	
PTN	PV cRcf
STEP	SV/MV/TIME Rf r

- Select the action for Control output (OUT2).
- Factory adjusted as Air.
- This setting item is available only when the option [DR, DS or DA] is added.
- With the type PC-955, this setting item is not available.
- Selecting item: Indicated on SV/MV/TIME display as shown below.

[HOLD] [ENT]

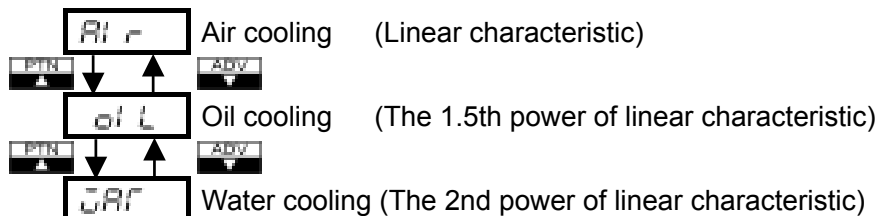

Control output (OUT2) high limit setting	
PTN	PV oLHb
STEP	SV/MV/TIME 100

HOLD
ENT

Control output (OUT2) low limit setting	
PTN	PV oLLb
STEP	SV/MV/TIME 0

HOLD
ENT

Control output (OUT2) ON/OFF hysteresis setting	
PTN	PV HYhb
STEP	SV/MV/TIME 10

HOLD
ENT

Overlap band/Dead band setting	
PTN	PV db
STEP	SV/MV/TIME 00

HOLD
ENT

- Set the Control output (OUT2) high limit.
- Setting range: Control output (OUT2) low limit setting value to 105%
Setting more than 100% is effective only to DC current output type.
- Factory adjusted as 100%.
- This setting item is available only when the option [DR, DS or DA] is added.
- With the type PC-955, this setting item is not available.
- This setting item is available only to Fixed value control parameter setting mode.

- Set the Control output (OUT2) low limit.
- Setting range: -5% to Control output (OUT2) high limit setting value
Setting less than 0% is effective only to DC current output type.
- Factory adjusted as 0%.
- This setting item is available only when the option [DR, DS or DA] is added.
- With the type PC-955, this setting item is not available.
- This setting item is available only to Fixed value control parameter setting mode.

- Set the Control output (OUT2) ON/OFF hysteresis.
- Setting range: 0.1 to 100.0°C (°F)
- Factory adjusted as 1.0°C
- This setting item is available only when the option [DR, DS or DA] is added.
- This setting item is not available to the type PC-955.

- Set the Overlap band/Dead band between Control output (OUT1) and Control output (OUT2).
Dead band: + setting, Overlap band: - setting
- Setting range: ±Control output (OUT1) Proportional band value converted
- Factory adjusted as 0.0°C
- This setting item is available only when the option [DR, DS or DA] is added.
- This setting item is not available to the type PC-955.

How to calculate ± proportional band converted value

[Calculation example] Sensor input: Thermocouple K type, -200 to 1370°C
 Proportional band: 10.0%

Calculating equation: $P_c = \pm [S_r \times P_b]$

Pc: Proportional band converted value (±157)

Where Sr: Sensor range span (1570)

Pb: Proportional band (0.1)

According to the calculation above mentioned, the Overlap band/Dead band setting range value is ±157.0°C.

Open/Closed output dead band setting	
PTN	PV <i>P_db</i>
STEP	SV/MV/TIME <i>30</i>

- Set the dead band value for Open output and Closed output.
- Setting range: 0.1 to 100.0% [Converted to Control output (OUT1) proportional band.]
- Factory adjusted as 3.0%
- This setting item is available only to the type PC-955.

↑HOLD
↓ENT

Open output time setting	
PTN	PV <i>P_of</i>
STEP	SV/MV/TIME <i>36.0</i>

- Set the time from valve full closed to full open.
- Setting range: 0.1 to 999.9 seconds
- Factory adjusted as 30.0 seconds
- This setting item is available only to the type PC-955.

↑HOLD
↓ENT

Closed output time setting	
PTN	PV <i>P_cf</i>
STEP	SV/MV/TIME <i>36.0</i>

- Set the time from valve full open to full closed.
- Setting range: 0.1 to 999.9 seconds
- Factory adjusted as 30.0 seconds
- This setting item is available only to the type PC-955.

↑HOLD
↓ENT

Setting for Output parameter is completed. If the **↑HOLD** key is pressed at the item **Closed output Time setting**, it returns to **Control output (OUT1) proportional cycle setting**.



When the setting is completed, press the **SET** key. The mode is returned to **Standby or Program Control running mode**.

● **Control output (OUT1) changing rate limit**

In case of heating control, and when the process variable is lower than the setting value, the control Output (OUT1) manipulating value generally changes from OFF to ON as shown Fig. 6.7-1, however, if the control output (OUT1) changing rate limit is applied, the changing rate of the control output (OUT1) manipulating value is changeable according to the rate setting as shown Fig. 6.7-2.

For example, it is utilized to heat the object gradually with high temperature heater (used at approximately 1500 to 1800℃) broken when conducted the current suddenly.

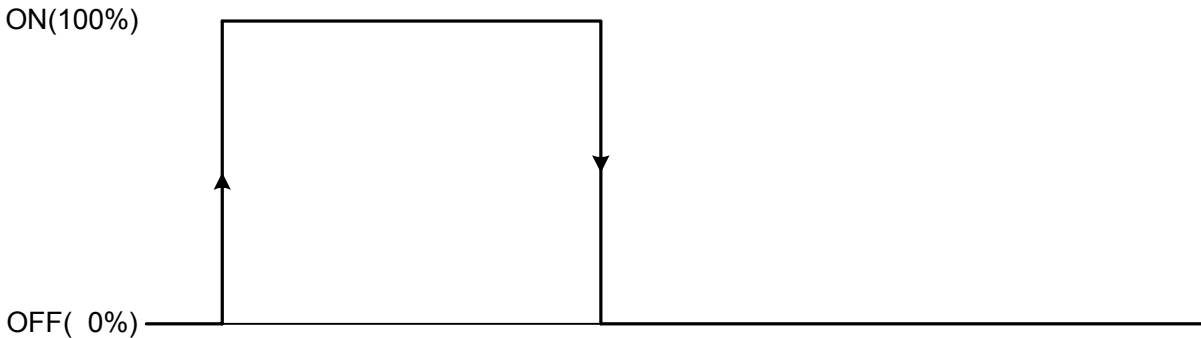

[Fig. 6.7-1]

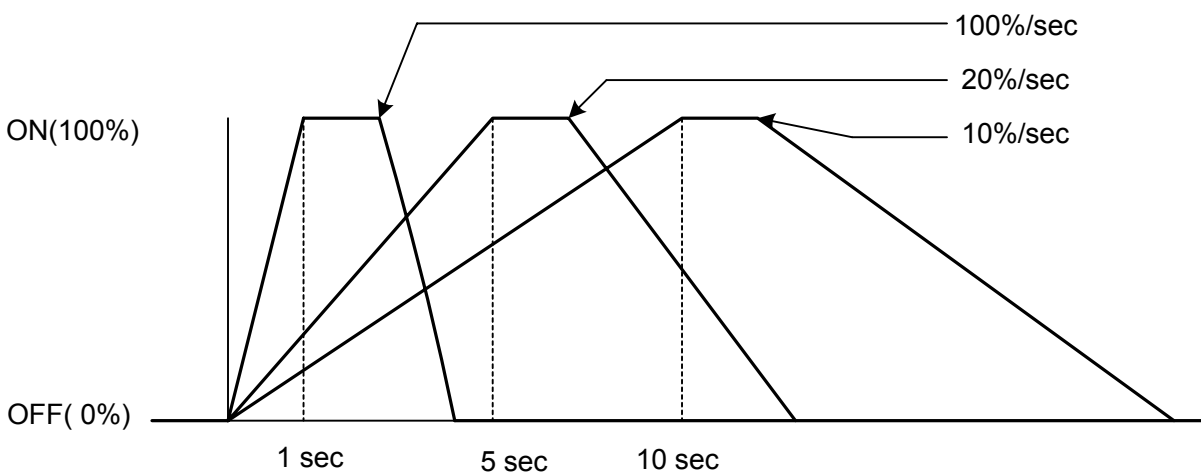

[Fig. 6.7-2]

● **How to measure the Open output time and Closed output time automatically.**

Simultaneously press the **PTR** and **ADW** keys after checking the valve position is full closed or full open.

Then the mode turns Open output time or Closed output time automatic measurement, it starts count from 0.0 seconds, besides the control motor open output or closed output turns ON, the motor moves to open or closed direction.

Press the **FAST** key when the valve reaches full open or closed. Then the count stops, it registers the Open output or Closed output time, besides the Control motor open or closed output turns OFF.

Main setting value limit setting

The main setting value limit setting items of **Program control running mode** are the same as those of **Fixed value control running mode**.

This section describes how to set in the **Program control running mode**.

Standby mode or Program control running mode	
PTN	PV
0	25
STEP	SV/MV/TIME



Program pattern setting mode	
PTN	PV
	Pf.n .
STEP	SV/MV/TIME



Attached function setting mode	
PTN	PV
	c.ond
STEP	SV/MV/TIME



Alarm parameter setting	
PTN	PV
	RL.A .
STEP	SV/MV/TIME



- In case of Fixed value control parameter setting mode, the character [P.f.n .] is indicated on the PV display.

Press the key several times until the character Attached function setting mode [c.ond] is indicated on the PV display. If passed, press the key.

Press the key several times until the character Main Setting value limit [RL.A .] is indicated on the PV display. If passed, use the key.

↓

Main setting value limit	
PTN	PV 41.5
STEP	SV/MV/TIME

[HOLD
ENT]

Main setting value (SV) high limit setting	
PTN	PV 4H
STEP	SV/MV/TIME 1370

[HOLD
ENT]

Main setting value (SV) low limit setting	
PTN	PV 4L
STEP	SV/MV/TIME -200

[HOLD
ENT]

Setting for Main setting value limit is completed. If the [HOLD ENT] key is pressed at the item **main setting value (SV) low limit setting**, it returns to **main setting value (SV) high limit setting**.

When the setting is completed, press the [SET/ENT] key. The mode is returned to **Standby or Program Control running mode**.

- Set the high limit value for main setting.
- Setting range: Main setting value low limit to Input range maximum value
In case of DC input,
Main setting value low limit to Scaling high limit setting value
(The decimal point place follows the selection.)
(See page 61)
- Factory adjusted as 1370°C
- Set the low limit value for main setting.
- Setting range: Input range minimum value to Main setting value high limit
In case of DC input,
Scaling low limit setting value to Main setting value high limit
(The decimal point place follows the selection.)
(See page 61)
- Factory adjusted as -200°C

Transmission output parameter setting

The Transmission output parameter setting items of **Program control running mode** are the same as those of **Fixed value control running mode**.

In case the option Transmission output [code: TA, TV] is added, the character transmission output parameter [f.o.] is indicated.

This section describes how to set the output parameter in the **Program control running mode**.

Standby mode or Program control running mode	
PTN	PV
0	25
STEP	SV/MV/TIME



Program pattern setting mode	
PTN	PV
	f.o.
STEP	SV/MV/TIME



Attached function setting mode	
PTN	PV
	cond
STEP	SV/MV/TIME



Alarm parameter setting	
PTN	PV
	RLA
STEP	SV/MV/TIME



- In case of Fixed value control parameter setting mode, the character [f.o.] is indicated on the PV display.

Press the key several times until the character Attached function setting mode [cond] is indicated on the PV display. If passed, press the key.

Press the key several times until the character Transmission output parameter [f.o.] is indicated on the PV display. If passed, use the key.

↓

Transmission output parameter	
PTN	PV
STEP	SV/MV/TIME

HOLD
ENT

Transmission output selection	
PTN	PV
STEP	SV/MV/TIME

HOLD
ENT

Transmission output high limit setting	
PTN	PV
STEP	SV/MV/TIME

HOLD
ENT

- Select the type of Transmission output.
- In case the option Transmission output [code: TA, TV] is added, this selecting item is indicated.
- Factory adjusted as Process variable transmission
- Selecting item: Indicated on SV/MV/TIME display as shown below.

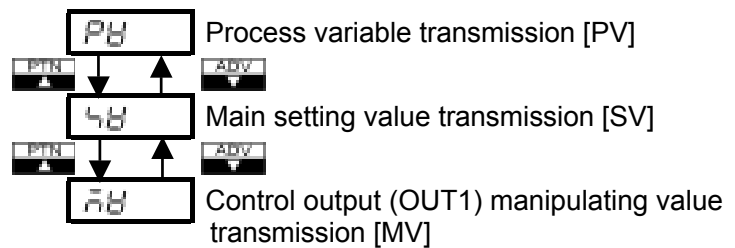

- Set the high limit of the Transmission output. The high limit value is the value when the output is 20mA (for option TA) or 1V (for option TV).
- Setting range: Transmission output low limit value to Input range maximum value
In case of DC input, the decimal point place follows the selection. (See page 61)
- Factory adjusted as 1370°C

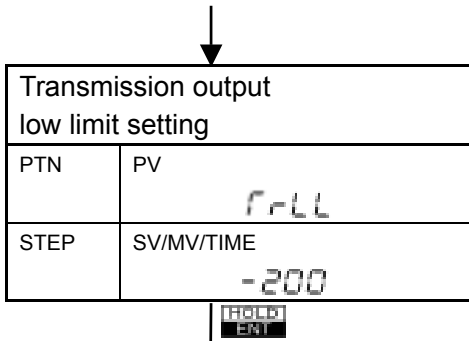

- Set the low limit of the Transmission output. The low limit value is the value when the output is 4mA (for option TA) or 0V (for option TV).
- Setting range: Input range minimum value to Transmission output high limit value. In case of DC input, the decimal point place follows the selection. (See page 61)
- Factory adjusted as -200°C

Setting for Transmission output parameter is completed. If the **HOLD/ENT** key is pressed at the item **Transmission output low limit setting**, it returns to **Transmission output high limit setting**.

When the setting is completed, press the **SET/ESC** key. The mode is returned to **Standby or Program Control running mode**.

- When the type of Transmission is selected by Transmission output selection, the Transmission output high limit value and low limit value are changed as follows.

[Table 6.7-1]

Type of Transmission output	High limit value	Low limit value
[PV] Process variable	Input range high limit value*	Input range low limit value*
[SV] Main setting value		
[MV] Control output (OUT1) manipulating value	100.0	0.0

* In case of Thermocouple K type of input, the High limit value: 1370°C , the low limit value: -200°C .

- During Standby mode, the Transmission output value is as follows.

[Table 6.7-2]

Type of Transmission output	Transmission output value
[PV] Process variable	The output value is the PV according to the high limit value and low limit value.
[SV] Main setting value	In case of option TA: 4mA TV: 0V
[MV] Control output (OUT1) manipulating value	

Input parameter setting

The input parameter setting items of **Program control running mode** are the same as those of **Fixed value control running mode**.

This section describes how to set the input parameter in the **Program control running mode**.

Standby mode or Program control running mode	
PTN	PV
0	25
STEP	SV/MV/TIME



Program pattern setting mode	
PTN	PV
	Pf.n.
STEP	SV/MV/TIME



Attached function setting mode	
PTN	PV
	c.ond
STEP	SV/MV/TIME



Alarm parameter setting	
PTN	PV
	RL.n.
STEP	SV/MV/TIME

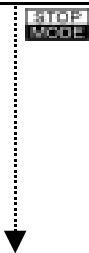

- In case of Fixed value control parameter setting mode, the character [P.f.n.] is indicated on the PV display.

Press the **STOP MODE** key several times until the character Attached function setting mode [c.ond] is indicated on the PV display. If passed, press the **HOLD ENT** key.

Press the **STOP MODE** key several times until the character Input parameter [i.n.p.] is indicated on the PV display. If passed, use the **HOLD ENT** key.

↓

Input parameter setting	
PTN	PV 1.0P.
STEP	SV/MV/TIME

[HOLD]
[ENT]

↓

Scaling high limit setting	
PTN	PV 4FLH
STEP	SV/MV/TIME 9999

[HOLD]
[ENT]

↓

Scaling low limit setting	
PTN	PV 4FL
STEP	SV/MV/TIME -999

[HOLD]
[ENT]

↓

- Set the Scaling high limit.
- This setting item is available only when DC input is designated by Sensor input type designation. (Page 11)
- Setting range: Scaling low limit setting value to Input range maximum value (Decimal point place follows the selection [See next page].)
- Factory adjusted as 9999.
- Set the Scaling low limit.
- This setting item is available only when DC input is designated by Sensor input type designation. (Page 11)
- Setting range: Input range minimum value to Scaling high limit setting value (Decimal point place follows the selection [See next page].)
- Factory adjusted as -1999.

Decimal point place selection	
PTN	PV
STEP	SV/MV/TIME

- Select the Decimal point place.
- This setting item is available only when DC input is designated by Sensor input type designation. (Page 11)
- Setting range: Indicated on SV/MV/TIME display as shown below.

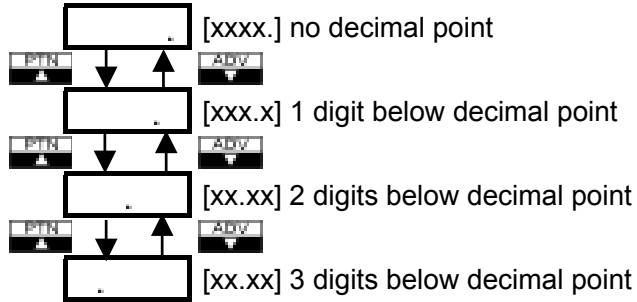

- Factory adjusted as [xxxx.] no decimal point.

Sensor correction setting	
PTN	PV
STEP	SV/MV/TIME

- Set the correction value for sensor.
- Setting range: -100.0 to 100.0°C(°F)
In case of DC input, -1000 to 1000
(Decimal point place follows the selection.)
- Factory adjusted as 0.0°C(°F)

PV filter time constant setting	
PTN	PV
STEP	SV/MV/TIME

- Set the PV filter time constant
- Setting range: 0.0 to 10.0 seconds
- Factory adjusted as 0.0 seconds

Setting for Input parameter is completed. If the key is pressed at the item **PV filter time constant setting**, it returns to **Scaling high limit setting**.

When the setting is completed, press the key. The mode is returned to **Standby or Program Control running mode**.

● What is the sensor correction function?

When a sensor cannot be set at a location where control is desired, the sensor measuring value may deviate from the value in the controlled location, and when controlling with plural PC-900s, the accuracy of sensors or the difference of load capacities have influence on the control.

Therefore, sometimes measuring value does not accord with the same setting value. In such a case, the control can be accorded with desired value by shifting the input value of sensors.

● What is the PV filter time constant?

It suppresses the unsteady input (influence by input noise) with the filter function on software having the same effect as CR filter by first-order lag operating the input value (PV).

When the input value changed in step type as shown Fig. 6.7-3, it changes slowly as shown Fig. 6.7-4.

T (PV filter time constant) means the time to reach to 63% of the change.



[Fig. 6.7-3]

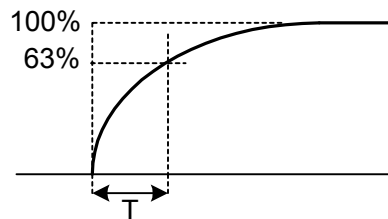

[Fig. 6.7-4]

Communication parameter setting

The Communication parameter setting items of **Program control running mode** are the same as those of **Fixed value control running mode**.

In case the option Serial communication [code: C, C5] is added, the character communication parameter [c.o.n.d] is indicated.

This section describes how to set the communication parameter in the **Program control running mode**.

Standby mode or Program control running mode	
PTN	PV
0	25
STEP	SV/MV/TIME



Program pattern setting mode	
PTN	PV
	P.F.n.
STEP	SV/MV/TIME



Attached function setting mode	
PTN	PV
	c.o.n.d
STEP	SV/MV/TIME



Alarm parameter setting	
PTN	PV
	RLA.
STEP	SV/MV/TIME



- In case of Fixed value control parameter setting mode, the character [P.F.n.] is indicated on the PV display.

Press the key several times until the character Attached function setting mode [c.o.n.d] is indicated on the PV display. If passed, press the key.

Press the key several times until the character Communication parameter [c.o.n.d] is indicated on the PV display. If passed, use the key.

↓

Communication parameter	
PTN	PV C000
STEP	SV/MV/TIME

HOLD
ENT

↓

Communication transfer rate selection	
PTN	PV C00P
STEP	SV/MV/TIME 96

HOLD
ENT

↓

Instrument number setting	
PTN	PV C000
STEP	SV/MV/TIME 0

HOLD
ENT

- Select the transfer rate to meet the rate of the Host computer.
- Selecting item: Indicated on SV/MV/TIME display as shown below.

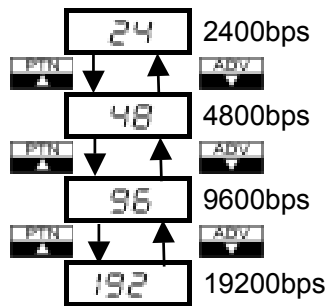

- Factory adjusted as 9600bps

- Set the Individual instrument number to this PC-900 when connecting plural PC-900s for communication. Do not set the same number as other PC-900.

- Setting range: 0 to 95
- Factory adjusted as 0

↓

Communication mode selection	
PTN	PV cñh
STEP	SV/MV/TIME noñL

- Select the Communication mode Serial communication or Setting value digital transmission.
- Selecting item: Indicated on SV/MV/TIME display as shown below.

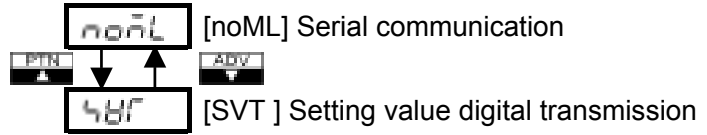

- Factory adjusted as Serial communication.

↓

HOLD
ENT

↓

Setting for Communication parameter is completed. If the HOLD
ENT key is pressed at the item **Communication mode selection**, it returns to **Communication transfer rate selection**.

↓

When the setting is completed, press the HOLD
ENT key. The mode is returned to **Standby or Program Control running mode**.

Other function setting

The other function setting items of **Program control running mode** are the same as those of **Fixed value control running mode**.

Only two items [**Setting value lock**] and [**Output selection when the Input burnout**] are applied in the **Fixed value control running mode**.

This section describes how to set the Other function in the **Program control running mode**.

Standby mode or Program control running mode	
PTN	PV
0	25
STEP	SV/MV/TIME



Program pattern setting mode	
PTN	PV
	P.F.L.
STEP	SV/MV/TIME

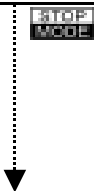

Attached function setting mode	
PTN	PV
	c.ond
STEP	SV/MV/TIME



Alarm parameter setting	
PTN	PV
	RLA
STEP	SV/MV/TIME

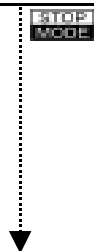

- In case of Fixed value control parameter setting mode, the character [P.F.L.] is indicated on the PV display.

Press the **STOP MODE** key several times until the character Attached function setting mode [c.ond] is indicated on the PV display. If passed, press the **HOLD/ENT** key.

Press the **STOP MODE** key several times until the character Other function [o.f.f.] is indicated on the PV display. If passed, use the **HOLD/ENT** key.

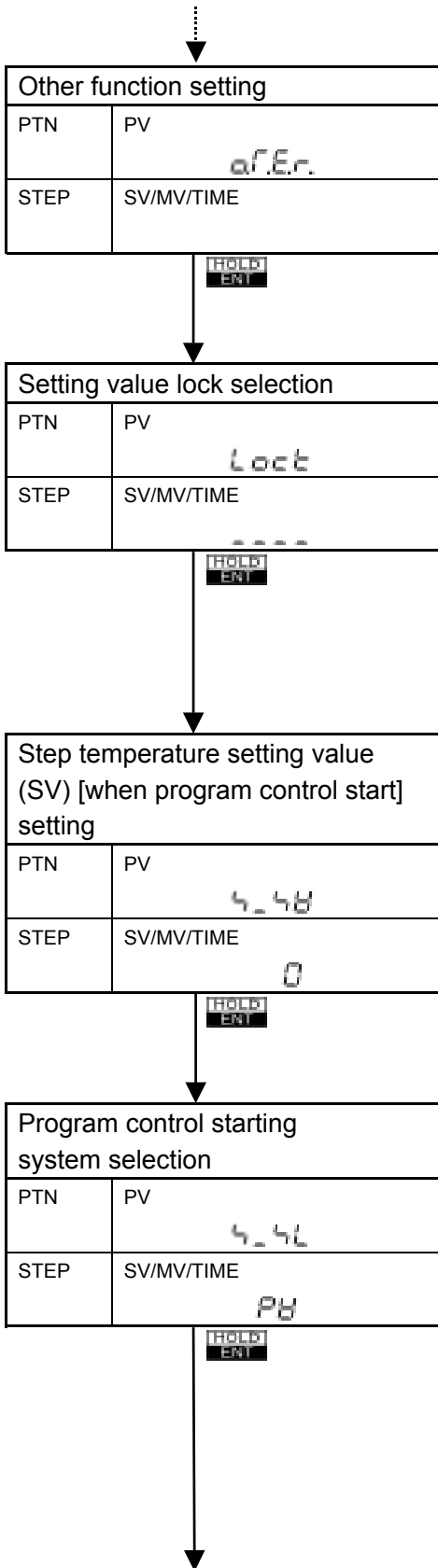

- Select whether the setting value is locked or not.
- Selecting item: Indicated on SV/MV/TIME display as shown below.

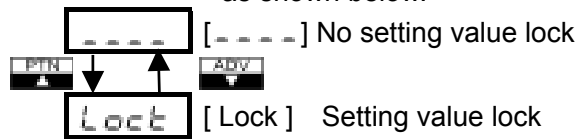

- [----] : All setting items can be changed.
- [Lock] : All setting items cannot be changed.
- Factory adjusted as No setting value lock

- Set the Step starting temperature setting value (SV). Regardless of Program control starting system, it starts the program control from the setting value.

- Setting range: Main setting value low limit to Main setting value high limit (Decimal point place to DC input follows the selection. (See page 61))
- Factory adjusted as 0°C

- Select the program control starting system.
- Selecting item: Indicated on SV/MV/TIME display as shown below.

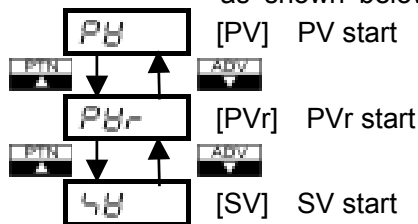

- Factory adjusted as [PV] PV start

- PV start [PV]
When started the Program control, it starts the control by quickly changing the Setting Value and the corresponding time to the Process variable (PV).
- PVr start [PVr]
Basically, the same as PV start, however, it also starts the control by PV start when Repeating the pattern.
- SV start [SV]
It starts the control from the SV set at “ Step temperature setting value (SV) [when program control start] setting “.

Status after power failure restored selection	
PTN	PV PrEr
STEP	SV/MV/TIME 4FOP

[HOLD] [ENT]

- Select the status, in case power failure occurs, and after it is restored.

- Selecting item: Indicated on SV/MV/TIME display as shown below.

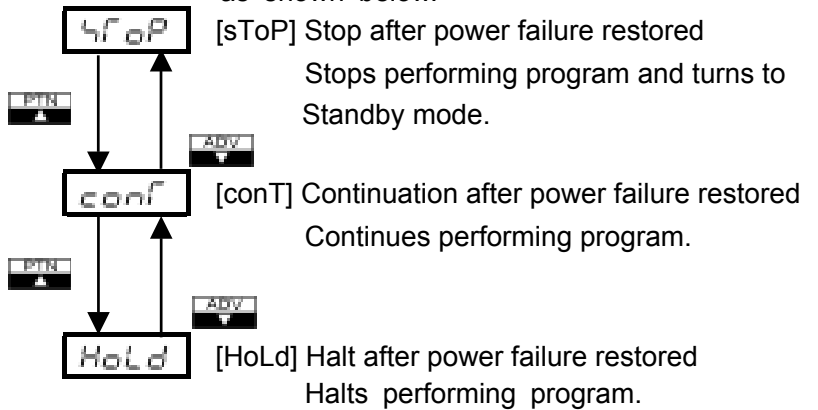

- Factory adjusted as Continuation after power failure restored

Step time unit selection	
PTN	PV 0.5
STEP	SV/MV/TIME 0.1

[HOLD] [ENT]

- Select the Step time unit for the program control.

- Selecting item: Indicated on SV/MV/TIME display as shown below.

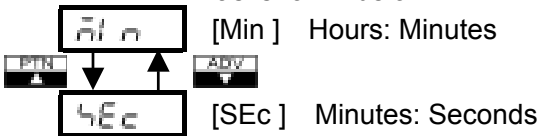

- Factory adjusted as Hours: Minutes

Step time indicating method selection	
PTN	PV 4.78
STEP	SV/MV/TIME r7

[HOLD] [ENT]

- Select the Step time indicating method when changed the SV/MV/TIME display to TIME during program control, whichever the Remaining time or the Step time setting value.
- Selecting item: Indicated on SV/MV/TIME display as shown below.

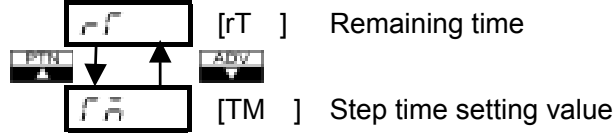

- Factory adjusted as Remaining time

Step temperature indicating method selection	
PTN	PV 4.78
STEP	SV/MV/TIME 48

[HOLD] [ENT]

- Select the Step temperature indicating method when changed the SV/MV/TIME display to SV during program control, whichever the Setting value correspond to the step time progress or Step temperature setting value.
- Selecting item: Indicated on SV/MV/TIME display as shown below.

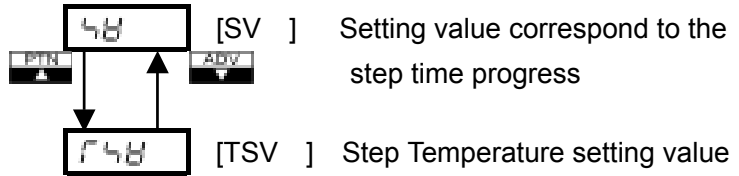

- Factory adjusted as Setting value correspond to the step time progress.

Pattern end output time setting	
PTN	PV PER7
STEP	SV/MV/TIME 0

[HOLD] [ENT]

- Set the time by second for Pattern end output when the Program control end.
Setting the time to 0 causes continuous output until the [STOP] [MODE] key is pressed for 1 second or the power supplied to the PC-900 is turned OFF.
- Setting range: 0 to 9999 sec
- Factory adjusted as 0 sec (continuous output)
- It does not work if the Pattern end output is not selected.

↓

Step temperature setting value (SV) when program end holding function, selection	
PTN	PV PEH
STEP	SV/MV/TIME 470P

- Select the function whether the Fixed value control is performed by holding the step temperature setting value (SV) of step 9 when program control end.
- PTN display blinks when the Hold function works.
- To cancel the Hold function, press the **STOP MODE** key for 1 second or turn the power supplied to PC-900 OFF
- Selecting item: Indicated on SV/MV/TIME display as shown below.

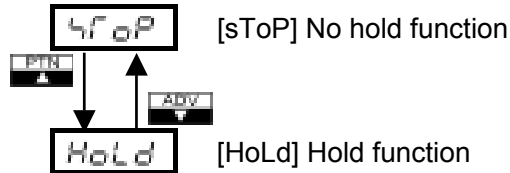

- Factory adjusted as No hold function [StoP].

- No hold function:

When the program is finished, if the Pattern end output is selected, it blinks [P.End] on SV/MV/TIME display and makes the Pattern end output ON. If it is not selected, not indicated on SV/MV/TIME display.

- Hold function:

The Fixed value control is performed by holding the step temperature setting value(SV) of step 9 when program control end. If no value is registered, it controls by Fixed value with The initial value (0°C).

↓

Time signal output/Status output (RUN) selection for TS1	
PTN	PV r4
STEP	SV/MV/TIME r4

- Select the Time signal output 1 whether it is used as Time signal output or Status output (RUN).
- Selecting item: Indicated on SV/MV/TIME display as shown below.



- Factory adjusted as Time signal output [TS]
- This setting item is available only when the option Time signal output is added.
- Status output (RUN) is ON during Program control.

↓

Time signal output/Status output (HOLD) selection for TS2	
PTN	PV r424
STEP	SV/MV/TIME r4

- Select the Time signal output 2 whether it is used as Time signal output or Status output (HOLD).
- Selecting item: Indicated on SV/MV/TIME display as shown below.

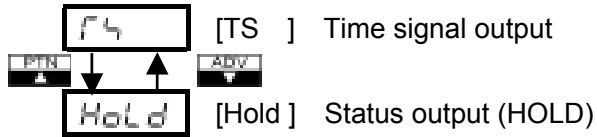

- Factory adjusted as Time signal output [TS]
- This setting item is available only when the option Time signal output is added.
- Status output (HOLD) is ON during Program control halt.

↓

Time signal output/Status output (WAIT) selection for TS3	
PTN	PV r434
STEP	SV/MV/TIME r4

- Select the Time signal output 3 whether it is used as Time signal output or Status output (WAIT).
- Selecting item: Indicated on SV/MV/TIME display as shown below.

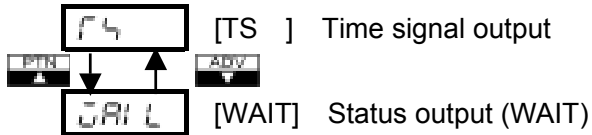

- Factory adjusted as Time signal output [TS]
- This setting item is available only when the option Time signal output is added.
- Status output (WAIT) is ON during Program control is waiting.

HOLD
[TS]

HOLD
[TS]

↓

Time signal output/Status output (FAST) selection for TS4	
PTN	PV r444
STEP	SV/MV/TIME r4

[HOLD] [ENT]

- Select the Time signal output 4 whether it is used as Time signal output or Status output (FAST).
- Selecting item: Indicated on SV/MV/TIME display as shown below.

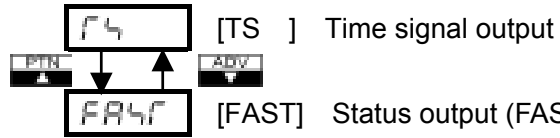

- Factory adjusted as Time signal output [TS]
- This setting item is available only when the option Time signal output is added.
- Status output (FAST) is ON when pressing the [FAST] key to progress the step time fast.

↓

Time signal output/Status output (STOP) selection for TS5	
PTN	PV r454
STEP	SV/MV/TIME r4

[HOLD] [ENT]

- Select the Time signal output 5 whether it is used as Time signal output or Status output (STOP).
- Selecting item: Indicated on SV/MV/TIME display as shown below.

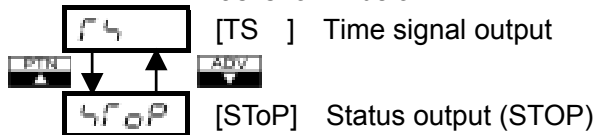

- Factory adjusted as Time signal output [TS]
 - This setting item is available only when the option Time signal output is added.
 - Status output (STOP) is ON when the status is Standby or Program control end.
- ↓

↓

Overshoot suppression factor setting	
PTN	PV 0.4F
STEP	SV/MV/TIME 10

- Set the factor to suppress overshoot.
- Setting range: 0.0 to 10.0
- Factory adjusted as 1.0
- Setting the Integral time to 0 disables this function.
- This setting item is displayed only when the DIP switch (SW304) No.1 is set to ON side to select the control action Fuzzy overshoot suppression PID.

[HOLD] [ENT]

↓

Output selection when the input burnout	
PTN	PV EoUF
STEP	SV/MV/TIME off

- Selects the control output to be OFF or not when the DC input is upscale or downscale.
- This setting item is available only when DC input.
- Setting item: Indicated on SV/MV/TIME display as shown below.

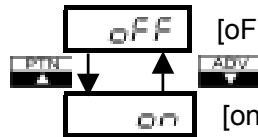

[off] [oFF] Makes the control output OFF

[on] [on] Makes the control output not to be OFF

- Factory adjusted as making the output OFF

[HOLD] [ENT]

↓

Setting for Other function setting is completed. If the [HOLD] [ENT] key is pressed at the item **Output selection when the input burnout**, it returns to **Setting value lock**.

↓

When the setting is completed, press the [SET] key. The mode is returned to **Standby or Program Control running mode**.

- **Overshoot suppression factor selection**

Performs the Auto-tuning by selecting the action to multi-mode. For the Overshoot suppression function, it is one of the condition that the values P, I, D and ARW are the optimum value by the Auto-tuning.

If the overshoot or undershoot occurs at the step changing point, select the optimum value from the range 0.5 to 10.0 of Overshoot suppression factor.

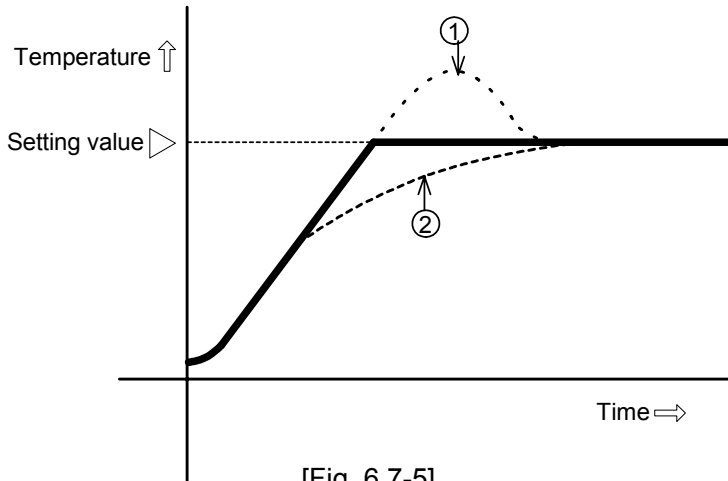

In case Overshoot is caused as shown①, make the factor larger.

In case too much time is necessary to be stable as shown②, make the factor smaller.

[Fig. 6.7-5]

6.8 Fixed value control parameter setting

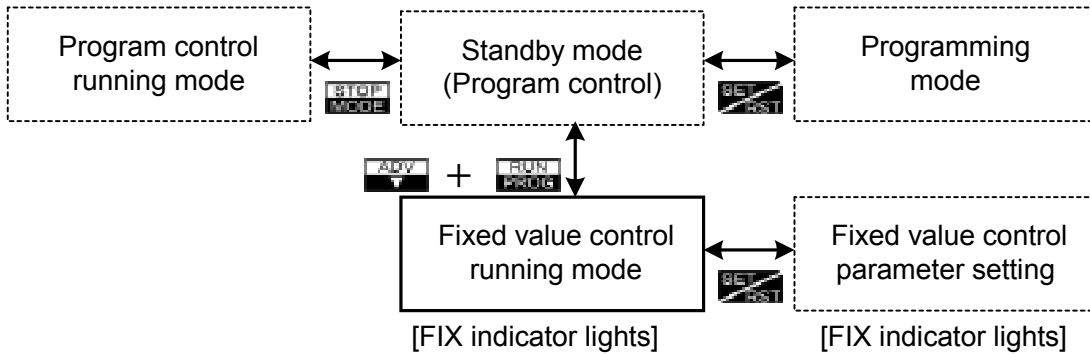

Main setting value (SV) setting

Fixed value control running mode	
PTN	PV 25
STEP	SV/MV/TIME 0



Fixed value control parameter setting mode	
PTN	PV F.L.L
STEP	SV/MV/TIME



Main setting value (SV)	
PTN	PV 4 . . .
STEP	SV/MV/TIME



Main setting value setting	
PTN	PV 4
STEP	SV/MV/TIME 0

- Set the Main setting value.
- Setting range: Main setting value low limit to Main setting value high limit
- Factory adjusted as 0°C

When the setting is completed, press the key. The mode is returned to **Fixed value control running mode**.

PID parameter setting

Fixed value control running mode	
PTN	PV 25
STEP	SV/MV/TIME 0



Fixed value control parameter setting mode	
PTN	PV F.V
STEP	SV/MV/TIME



Main setting value (SV)	
PTN	PV 4.00
STEP	SV/MV/TIME



PID parameter setting	
PTN	PV P.I.d
STEP	SV/MV/TIME



Control output (OUT1) proportional band setting	
PTN	PV P
STEP	SV/MV/TIME 20



Integral time setting	
PTN	PV I
STEP	SV/MV/TIME 180



- Set the Proportional band of control output (OUT1). Setting the value to 0.0% causes the PC-935 to act as an ON/OFF controller.
- Setting range: 0.0 to 999.9% (For PC-935 type)
0.1 to 999.9% (For PC-955 type)
- Factory adjusted as 2.5%

- Set the Integral time. Setting the value to 0 disables the function.
- Setting range: 0 to 3600 seconds (For PC-935 type)
1 to 3600 seconds (For PC-955 type)
- Factory adjusted as 200 seconds

Derivative time setting	
PTN	PV d
STEP	SV/MV/TIME 30

- Set the Derivative time.
Setting the value to 0 disables the function.
- Setting range: 0 to 1800 seconds
- Factory adjusted as 50 seconds

Anti-reset windup setting	
PTN	PV n
STEP	SV/MV/TIME 50

- Set the Anti-reset windup.
- Setting range: 0 to 100%
- Factory adjusted as 50%

Control output (OUT2) proportional band setting	
PTN	PV Pb
STEP	SV/MV/TIME 10

- Set the Control output (OUT2) proportional band. Multiplying factor setting to Control output (OUT1) Proportional band. The equation is as follows.

Setting the value to 0.0 causes the PC-900 to act as an ON/OFF controller. If the Proportional band of Control output (OUT1) is 0.0%, it acts as an ON/OFF controller as well.

- Setting range: 0.0 to 10.0 (Multiplying factor)
- Factory adjusted as 1.0
- This setting item is available only when the option Control output (OUT2) [code: DR, DS or DA] is added.
- With the type PC-955, this setting item is not available.

«Equation»

$$\text{Control output (OUT2) Proportional band} = \text{Control output (OUT1) Proportional band} \times \text{Multiplying factor}$$

Data setting for PID parameter is completed. Press the  key, the mode is returned to **Fixed value control running mode**.

Alarm action point setting

Fixed value control running mode	
PTN	PV 25
STEP	SV/MV/TIME 0



Fixed value control parameter setting mode	
PTN	PV F.V.
STEP	SV/MV/TIME



Main setting value (SV)	
PTN	PV
STEP	SV/MV/TIME



Press the **STOP MODE** key several times until the character Alarm action point [R . . .] is indicated on the PV display.

Alarm action point setting	
PTN	PV R . . .
STEP	SV/MV/TIME



Alarm 1 (A1) action point setting	
PTN	PV A1
STEP	SV/MV/TIME 0



- Set the Alarm (A1) action point.
- Setting range: See the table on the next page.
- Factory adjusted as Pattern end output 1
- This item is not available when Pattern end output 1 is selected (initial status), and if no alarm action is selected by rotary switch (SW302, See page 12).

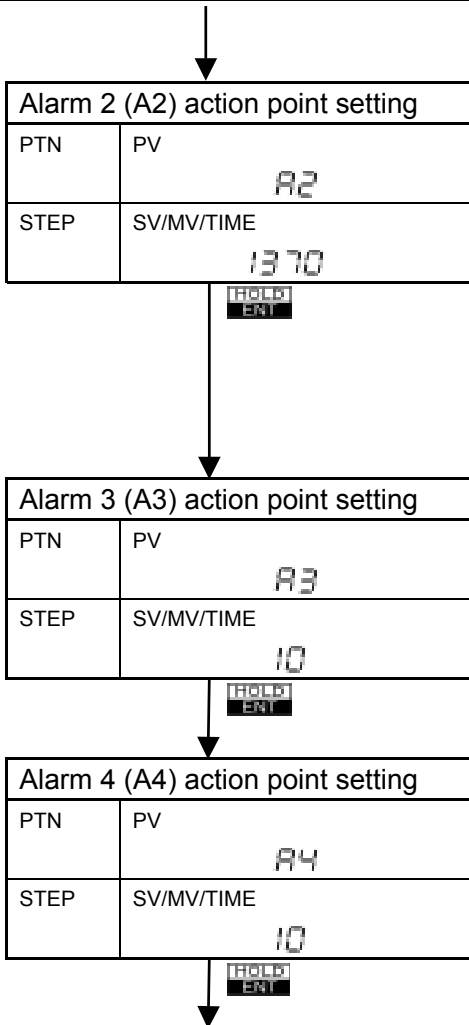

- Set the Alarm 2 (A2) action point.
- Setting range: See the table below.
- Factory adjusted as 0℃.
- This item is not available to following cases.
 - (1) Option A2 is not applied.
 - (2) No alarm action or Pattern end output 2 is selected by rotary switch (SW301, See page 12).
 - (3) For the type PC-955.

- Set the Alarm 3 (A3) action point.
- Setting range: See the table below.
- Factory adjusted as 0℃
- This item is not available when No alarm action or Pattern end output 3 is selected by key operation in Alarm 3 (A3) action form selection (See page 44).

- Set the Alarm 4 (A4) action point.
- Setting range: See the table below.
- Factory adjusted as 0℃
- This item is not available when No alarm action or Pattern end output 4 is selected by key operation in Alarm 4 (A4) action form selection (See page 45).

Data setting for Alarm action point is completed. Press the key, the mode is returned to **Fixed value control running mode**.

● Alarm 1 to Alarm 4 setting range (The same range is applicable to Standby function)

[Table 6.8-1]

Type of alarm	Setting range	Setting range (with decimal point)
High limit alarm (*)	-Input range span to Input range span	-199.9 to Input range span
Low limit alarm (*)	-Input range span to Input range span	-199.9 to Input range span
High/Low limits alarm (*)	0 to Input range span	0.0 to Input range span
High/Low limit range alarm (*)	0 to Input range span	0.0 to Input range span
Process high alarm	Input range minimum value to Input range maximum value	-199.9 to Input range maximum value
Process low alarm	Input range minimum value to Input range maximum value	-199.9 to Input range maximum value

(*): Deviation setting

When the input type is DC, for [Input range span] read [Input range scaling span].

Attached function setting mode

It includes the undermentioned parameters and setting items.

How to set and setting item are the same as [each parameter of Program control running mode],

[Alarm parameter]

- Alarm 3 (A3) action form selection
- Alarm 4 (A4) action form selection
- Alarm 1 (A1) hysteresis setting
- Alarm 2 (A2) hysteresis setting *1
- Alarm 3 (A3) hysteresis setting
- Alarm 4 (A4) hysteresis setting
- Alarm 1 (A1) delayed timer setting
- Alarm 2 (A2) delayed timer setting *1
- Alarm 3 (A3) delayed timer setting
- Alarm 4 (A4) delayed timer setting
- Loop break alarm time setting *2
- Loop break alarm span setting *2

*1 This setting item is available when Option A2 is applied.

*2 This setting item is available when Option LA is applied.

[Output parameter]

- Control output (OUT1) proportional cycle setting
 - Control output (OUT1) high limit setting
 - Control output (OUT1) low limit setting
 - Control output (OUT1) ON/OFF hysteresis setting
 - Control output (OUT1) changing rate limit setting
 - Control output (OUT2) proportional cycle setting *3
 - Control output (OUT2) action selection *3
 - Control output (OUT2) high limit setting *3
 - Control output (OUT2) low limit setting *3
 - Control output (OUT2) ON/OFF hysteresis setting *3
 - Overlap band/Dead band setting *3
 - Open/Closed output dead band setting *4
 - Open output time setting *4
 - Closed output time setting *4
- *3 This setting item is available when Option [DR, DS or DA] is added.
- *4 This setting item is available only to the type PC-955.

[Main setting value limit]

- Main setting value (SV) high limit setting
- Main setting value (SV) low limit setting

[Transmission output parameter]

- Transmission output selection *5
 - Transmission output high limit setting *5
 - Transmission output low limit setting *5
- *5 In case Option [TA or TV] is added, this setting item is indicated.

[Input parameter]

- Scaling high limit setting
- Scaling low limit setting
- Decimal point place selection
- Sensor correction setting
- PV filter time constant setting

[Communication parameter]

- Communication transfer rate selection *6
 - Instrument number setting *6
 - Communication mode selection *6
- *6 In case Option [C or C5] is added, this setting item is indicated.

[Other function]

- Setting value lock selection
- Output selection when the input burnout

7 Running

7.1 Program setting

Before starting the Program control, check following matters.

[Before the power is turned on]

- Mounting to control panel (See page 9)
- Wiring connection (See page 14)
- Set-up (See page 6)

[After the power is turned on]

- When the mode is in Fixed value control (Indicator [FIX] lights), press the  key.

- (1) Program pattern setting (See page 21)
- (2) Block data setting (See page 26)
- (3) Number of repeat of the pattern and Pattern link setting (See page 41)
- (4) Attached function setting (See page 43)

In case of PC-955 type, the Open/Closed output time setting, etc. to meet to control valve motor.

- (5) Auto/Manual control changing (See page 86)
- (6) Pattern number selection

[Pattern number selection by External operation]

The Pattern number 1 to 7 can be selected by external terminal connection.

(The Pattern number selected by Pattern number External operation takes priority over the key operation on front panel.)

Referring to [Table 7.1-1], select the Pattern number by connecting between ⑬, ⑭ and/or ⑮ and ⑯ (common).



[Table 7.1-1]

Instrument terminal	Pattern number							
	0	1	2	3	4	5	6	7
⑬ b0		○		○		○		○
⑭ b1			○	○			○	○
⑮ b2					○	○	○	○

For example, when selecting the Pattern number 7, connect ⑬ and ⑯, ⑭ and ⑯, and ⑮ and ⑯. To cancel the number, open the terminal between ⑬ and ⑯, ⑭ and ⑯, and ⑮ and ⑯.

7.2 Program control running

[Starting System]

- Automatic start: Turn the power supplied to the PC-900 on, and the program is automatically started from the step 0 after warm-up status.
When making the program start automatically, slide the No. 8 switch of the DIP switch (SW304) to ON side before the power supplied to the PC-900 is on.
- Manual start : After the power is turned on and warm-up is completed, the program is started from the step 0 by pressing the  key in case of Standby mode.
When Fixed value control running mode, press the  key. The mode is returned to Standby mode.
When making the program start manually, slide the No. 8 switch of the DIP switch (SW304) to OFF side before the power supplied to the PC-900 is on.

[Status when the Program control is started]

- SV start : It starts the control from the SV set “ Step temperature setting value (SV) [when program control start] setting”.
- PV start : It starts the control from the PV by quickly changing the Setting value and the corresponding time to the Process variable (PV).
- PVr start : The same as PV start, however, it also starts the control by PV start when repeating the pattern.

[Program control running by External operation]

Program control is started by closing the terminal between  –  with the contact or Open collector.

- RUN input : It is processed at the ON rising edge.

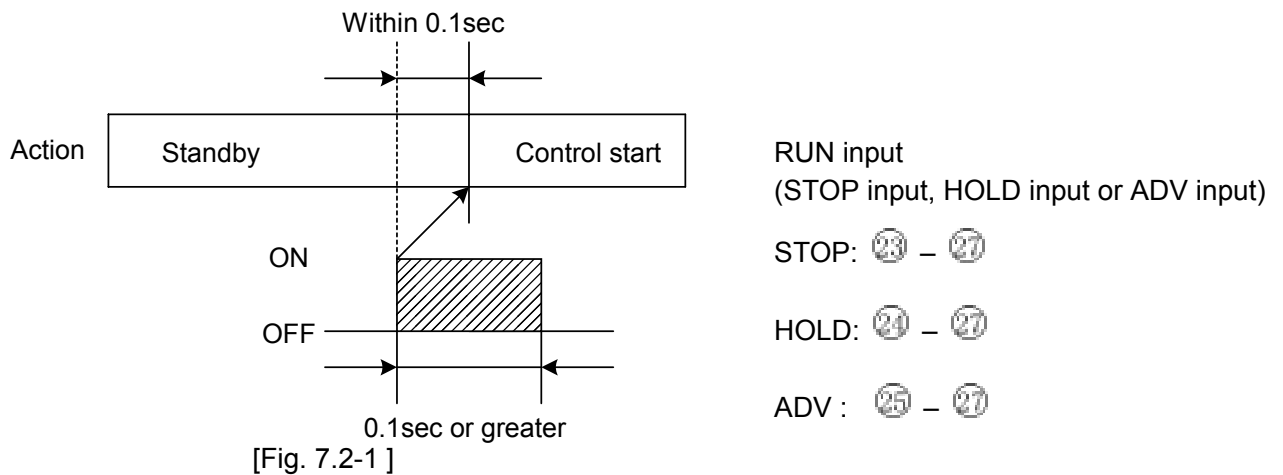



[Program control halt (HOLD)]



Press the  key to halt the time progress, and it performs the Fixed value control by the setting value at that time. At this time, the HOLD indicator (Red) lights.

To perform the program control again, press the  key.

[Step progressing (ADV)]

Each time the  key is pressed, the step is progressed to the next. Even if the Wait function is working, if the  key is pressed, it is progressed to the next.

[Step backing (Back advance)]

Each time the  key is pressed while the  key is being pressed, it ends the step on the process, and the step goes back to the previous and performs the control.

[Step time fast progress (FAST)]

While the  key is pressed and held, the time progress becomes 60 times as fast as usual. If the Wait action is applied, the Wait function takes priority over this function.



[Program control end on the process (STOP)]

Press the  key, and the Program control will be stopped on the process.

[Program control end (P. END)]

When the Program control is finished, the mode turns to Standby, and the A1/SB indicator lights and the character *P.END* blinks on SVMV/TIME display. Besides, the Pattern end output turns on. If the  key is pressed for 1 second or greater, the Pattern end output turns off.

[Step setting value change during running]

During running, to change the setting value, press the  key to turn the mode to Programming mode. After setting, press the  key again to turn the mode to running. If the step temperature or step time is changed, the control is changed as follows.

[When the step temperature is changed from SV1 to SV2.]

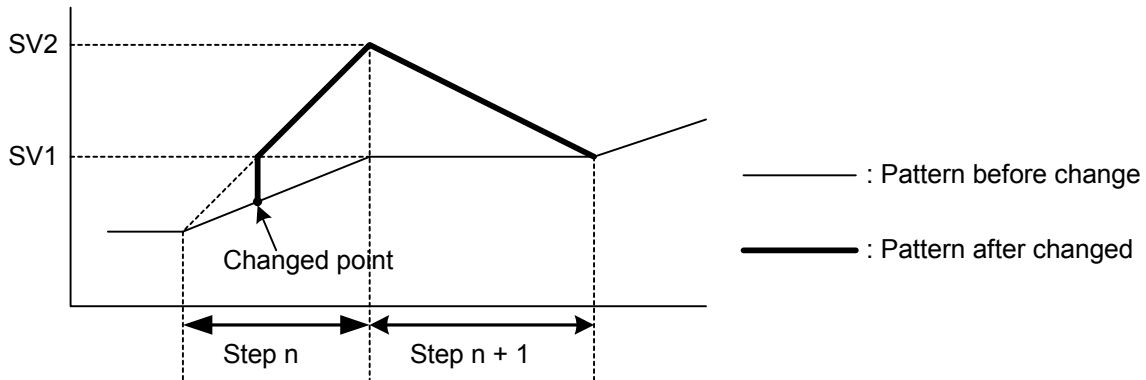

[Fig. 7.2-2]

[When the step time is changed from T1 to T2.]

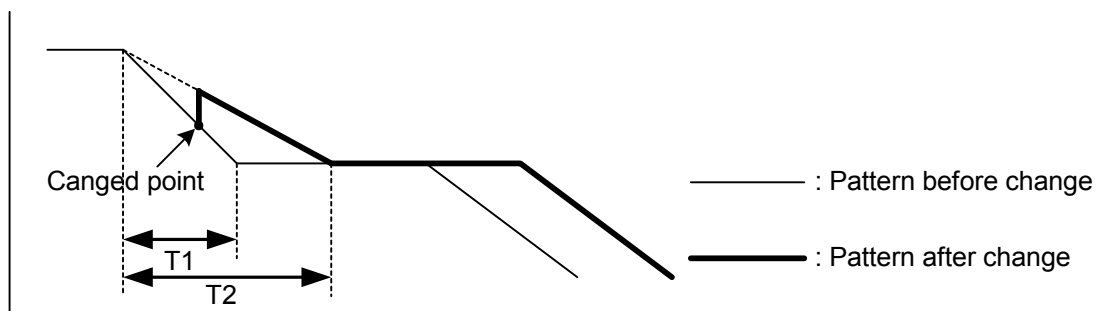

[Fig. 7.2-3]



7.3 Fixed value control running

Before starting the Fixed value control, check following matters.

[Before the power is turned on]

- Mounting to control panel (See page 9)
- Wiring connection (See page 14)
- Set-up (See page 6)

[After the power is turned on]

- When the mode is in Program control (PTN display lights), press the  key while the  key is being pressed to make the mode to Fixed value control.

Then press the  key to change the mode to setting.

- (1) Fixed value parameter setting (See page 75)
- (2) Attached function setting (See page 43)
- (3) Auto/Manual control changing (See page 86)

When the setting is completed, press the  key. The control action is started so as to maintain the controlling object at the main setting value.

[Key operations during Fixed value control]



key: Changes the indication on SV/MV/TIME display SV or MV.



key: Ends the Fixed value control and turns the mode to Program control (Standby).

7.4 Manual control performance

Output manipulating value is set by manual.

● Auto/Manual control change

Control change method is common to [Fixed value control running mode] and [Program control running mode]. Therefore, about the Program control is described in this section.

Standby mode or Program control running mode	
PTN	PV
0	25
STEP	SV/MV/TIME



Program pattern setting mode	
PTN	PV
	Pf.n .
STEP	SV/MV/TIME



- In case of Fixed value control parameter setting mode, the character [P.f.n.] is indicated on the PV display.

Press the key several times until the character Auto/Manual control changing mode [MANU] is indicated on the PV display. If passed, press the key.

Auto/Manual control changing mode	
PTN	PV
	MANU
STEP	SV/MV/TIME



Auto/Manual control change	
PTN	PV
	MANU
STEP	SV/MV/TIME
	AUF 0

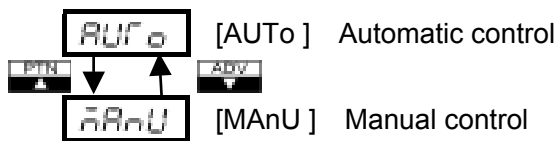

- Change the control mode Automatic or Manual.
- Setting item: Indicated on SV/MV/TIME display as shown below.



- Factory adjusted as Automatic control

When changed the control mode, press the key.

[Key operation in Manual control]

During Manual control, use the ,  and  keys to increase or decrease the output manipulating value.

Setting range: Fixed value control output (OUT1) low limit to high limit value

Maximum range, 0.0 to 100.0% (R/M, S/M), -5.0 to 105.0% (A/M)

[When the option Heating and Cooling control output (code: DR, DS or DA) is add.]

Setting range: —Fixed value control output (OUT2) high limit to Fixed value control output (OUT1) high limit

Maximum range, -100.0 to 100.0% (R/M, S/M), -105.0 to 105.0% (A/M)

[In case of PC-955 type, the value status is as follows]

Control output manipulating value 0.0% ⇔ Full closed

Control output manipulating value 100.0% ⇔ Full open

When control output manipulating value is 0.1% to 99.9%, the Open output ON time and Closed output ON time are decided by the control output manipulating value at the time and the setting values (Open/Closed output dead band, Manipulating value operating cycle, Open output time, Closed output time, etc.), thus the valve flow rate is adjusted.

[With Manual control, refer to following parameters for Fixed value control.]

- Control output (OUT1) high limit setting value
- Control output (OUT1) low limit setting value
- Control output (OUT1) changing rate limit setting value
- Control output (OUT2) high limit setting value (Option DR, DS or DA is applied to PC-935)
- Control output (OUT2) low limit setting value (Option DR, DS or DA is applied to PC-935)
- Open output time setting value (only to PC-955)
- Closed output time setting value (only to PC-955)

[Balanceless-bumpless function]

The function not to suddenly change the output manipulating value when the control mode is changed from automatic to manual and vice versa.

- In case the mode is changed from automatic to manual, it makes the output manipulating value before change to the initial value for manual control.
- In case the mode is changed from manual to automatic, it makes the output manipulating value before change to the initial value for automatic control.

7.5 SV/MV/TIME display change

Each time the  key is pressed, the indication on SV/MV/TIME changes as follows.

• Program control

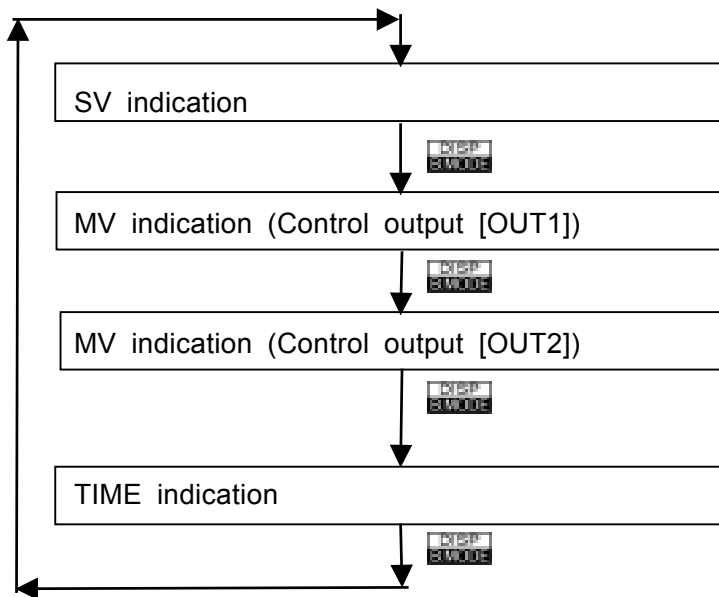

Step temperature is indicated on SV/MV/TIME display.

Output manipulating value is indicated on SV/MV/TIME display.

Output manipulating value is indicated on SV/MV/TIME display.
(In case the option DR, DS or DA is applied.)

Step time is indicated on SV/MV/TIME display.

• Fixed value control

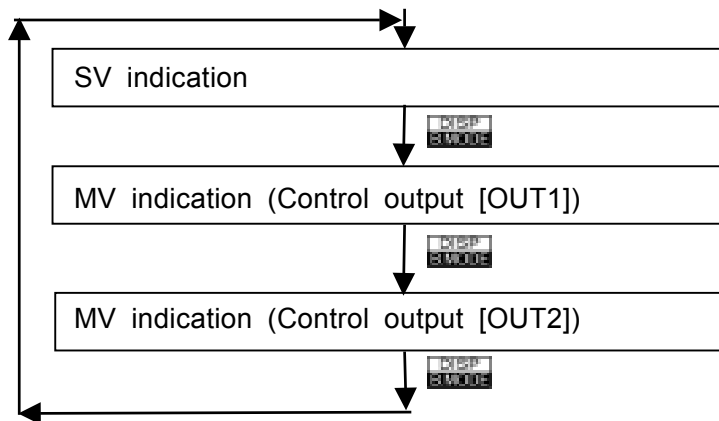

Main Setting value is indicated on SV/MV/TIME display.

Output manipulating value is indicated on SV/MV/TIME display.

Output manipulating value is indicated on SV/MV/TIME display.
(In case the option DR, DS or DA is applied.)

7.6 Notes when PID auto-tuning is performing

- If [Lock] is designated in Setting lock selection, Fuzzy overshoot suppressing PID auto-tuning or PID auto-tuning cannot be worked.
- During PID auto-tuning, all parameter cannot set.

[In program control running mode]

When the PID auto-tuning is performed, it starts the tuning at the point, and the program time is not progressed until the tuning is completed. The remaining time is performed after the tuning is terminated.

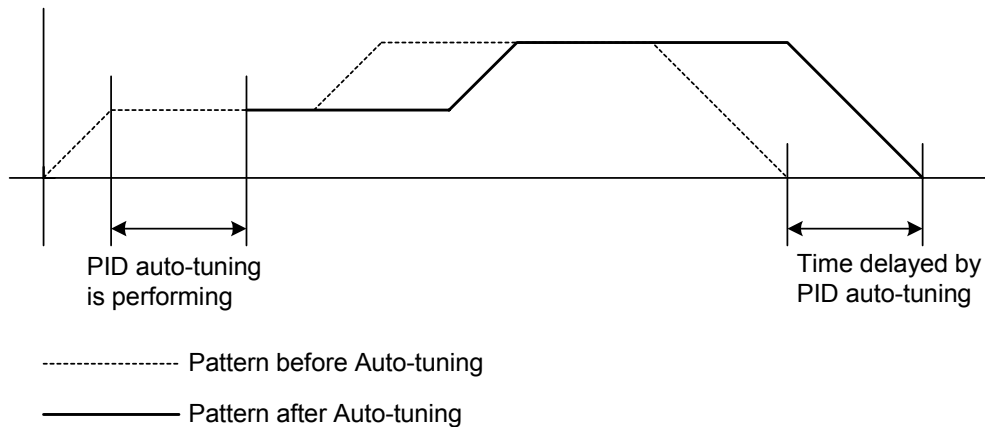

[Fig 7.6-1]

In case of Multi mode , when setting the PID auto-tuning at the point the program control is started, the PID auto-tuning is automatically performed at the elapsed point (A) of 90% of progress time on each step. In case the same PID block is set in 1 pattern (e.g. step 1 and 3), the tuning is performed only the first step (e.g. step 1), and the later step (e.g. step 3) is ignored. After the PID auto-tuning is terminated for each step, the values Control output (OUT1) proportional band, Integral time, Derivative time, ARW and Control output (OUT2) proportional band are automatically set to the PID block number selected at each step.

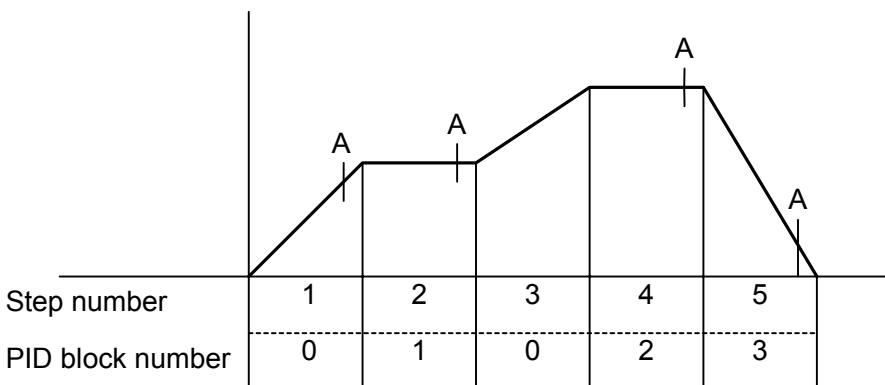

When the PV reached at A point, PID auto-tuning is automatically performed.

[Fig. 7.6-2]

When performing the Multi mode PID auto-tuning, AT indicator lights, and when it is performing the auto-tuning after the PV reached at A point, AT indicator blinks.

7.7 PID auto-tuning performance/cancellation

This section describes how to set in the **Program control running mode**.

Standby mode or Program control running mode	
PTN	PV
0	25
STEP	SV/MV/TIME



Program pattern setting mode	
PTN	PV
	Pf.n.
STEP	SV/MV/TIME



Auto-tuning performing mode	
PTN	PV
	Rf...
STEP	SV/MV/TIME



PID auto-tuning action selection	
PTN	PV
	Rf4
STEP	SV/MV/TIME
	noML



- In case of Fixed value control parameter setting mode, the character [F.V.] is indicated on the PV display.

Press the **STOP MODE** key several times until the character Auto-tuning performing mode [Rf. . .] is indicated on the PV display.
If passed, press the **HOLD/ENT** key.

- Select the action of PID auto-tuning.
- Setting item: Indicated on SV/MV/TIME display as shown below.

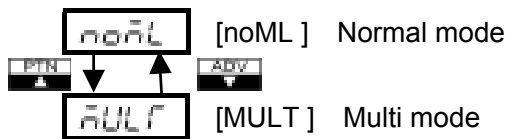

- Factory adjusted as Normal mode

- Normal mode: When the PID auto-tuning is designated, it starts the auto-tuning at once.
- Multi mode: It automatically starts the PID auto-tuning at the elapsed point (A) of 90% of progress time on each step. In case the same PID block is set in 1 pattern, the tuning is performed only the first step, and the later step is ignored.
When controlling by Fixed value, it is ineffective.

PID auto-tuning Performance/cancellation	
PTN	PV AF
STEP	SV/MV/TIME -----



- Select Performance or Cancellation of the PID auto-tuning.
- Setting item: Indicated on SV/MV/TIME display as shown below.

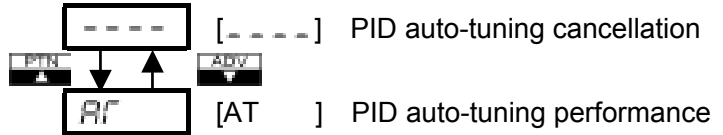

- Factory adjusted as PID auto-tuning cancellation

- PID auto-tuning performance can be designated when controlling by Program or Fixed value. During PID auto-tuning, the decimal point (AT, end of the right) on the SV/MV/TIME display blinks, and the values displayed are in their stopping status.
- During PID auto-tuning, all parameters cannot be set. When changing the setting, cancel the PID auto-tuning once.
- The PID auto-tuning can be cancelled even the tuning is performing. However, the values Control output (OUT1) proportional band, Integral time, Derivative time, ARW and Control output (OUT2) proportional band return to the values before the auto-tuning was started.
In case 4 hours passed after starting the auto-tuning, and it is not finished, it will be automatically canceled, and the values abovementioned return to the values before the auto-tuning was started.
- If selected normal mode at PID auto-tuning action selection, perform the tuning at each step.
- When the PID auto-tuning is finished, the decimal point (AT, end of the right) on the SV/MV/TIME display turns out, and each value Control output (OUT1) proportional band, Integral time, Derivative time, ARW (Anti-reset windup) and Control output (OUT2) proportional band are automatically set.

When the changing is completed, Press the key.

8. Explanation of Control action and Alarm action

8.1 Fuzzy overshoot suppression PID action

It always watches the changing rate of the control output manipulating value and the deviation from the program control starting point, and suppresses the control output manipulating value before the step is changed, thus the overshoot is suppressed.

- PID auto-tuning should be performed to each step in advance.
- Fuzzy overshoot suppression PID auto-tuning will not work when the Integral time (I) is set to 0.
- When Wait or Hold function works, Fuzzy overshoot suppression PID auto-tuning is cancelled.

8.2 Explanation of PID and ARW

Proportional band (P)

Proportional action is the action of which the control output varies in proportion to the deviation between setting value and processing value.

If the proportional band is narrowed, the output changes according to even by a slight variation of the processing value, and better control result can be obtained as the offset decreases.

However, if when the proportional band is extremely far too narrowed, it may cause variation in the processing value even by slight disturbance, and turns into control such as ON/OFF action of the so called hunting phenomenon.

Therefore, when the processing value comes to the balanced position near the setting value and a constant value is maintained, the most suitable value is selected by gradually narrowing the proportional band while observing the control results.

Integral time (I)

Integral action is to eliminate offset. When the integral time is shortened, the returning speed to the setting point is quickened. However, the cycle of oscillation is also quickened and stability becomes unfavorable.

Derivative time (D)

Derivative action is to restore the change of processing value according to the changing rate.

It reduces the amplitude of overshoot and undershoot width.

If the derivative time is shortened, restoring value comes small, and if the derivative time is adjusted longer, a phenomenon of returning too much may occur and the control system may be oscillated.

Anti-reset windup (ARW)

ARW prevents overshoot (undershoot) caused owing to the integral action. In case of Fixed value control, the less ARW value is, the less excess integral action becomes at the point the PV reaches to the setting value. However, it needs time till stabilized.

For Program control, ARW is used with the overshoot suppression coefficient, it suppresses the overshoot (undershoot) at the point the gradient of each step is changed.

(When setting Wait value, this function does not work to the step.)

● **How to get the duty factor for ARW by manual setting**

In case of Relay contact output or Non-contact voltage output

$$\text{Duty factor (\%)} = \frac{\text{ON action time}}{\text{Proportional cycle}} \times 100(\%)$$

In case of Current output

$$\text{Duty factor (\%)} = \frac{\text{Output current value (mA)} - 4}{16} \times 100(\%)$$

- Set to 50% (the same as factory adjusted) for trial run, if duty factor is unknown.

8.3 PID auto-tuning of this controller

In order to decide each value of P, I, D and ARW automatically, this system gives the fluctuation to the controlling object by force.

[In case the difference between setting value and processing temperature is large when the the temperature rises.]

Fluctuation is given at the temperature 1.5% of scaling span less than the setting value.

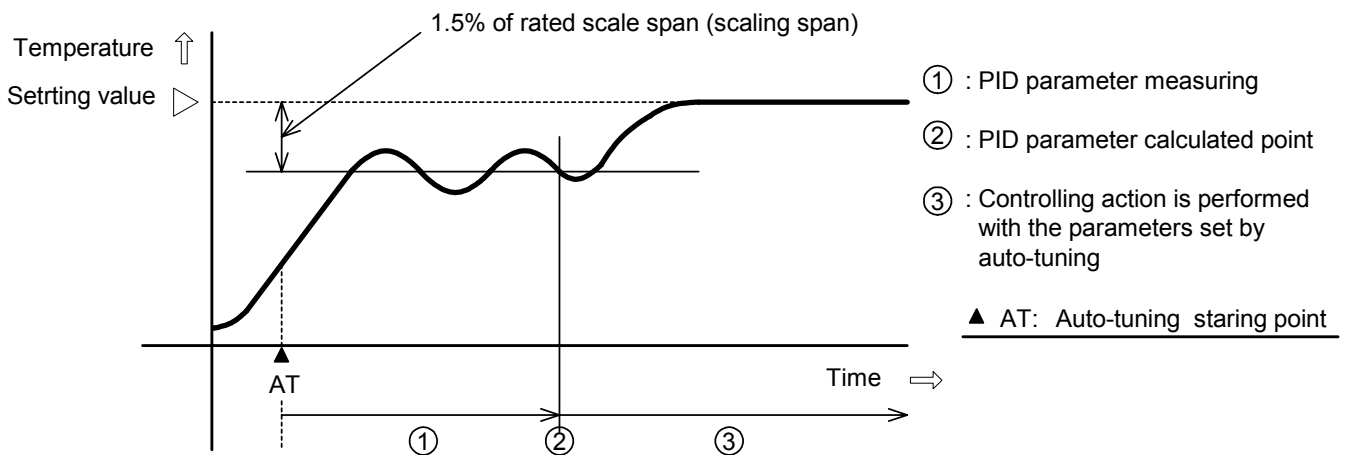

[Fig. 8.3-1]

[In case of the stable situation during control or when control temperature is within $\pm 1.5\%$ of scaling span.]

Fluctuation is given at the setting value.

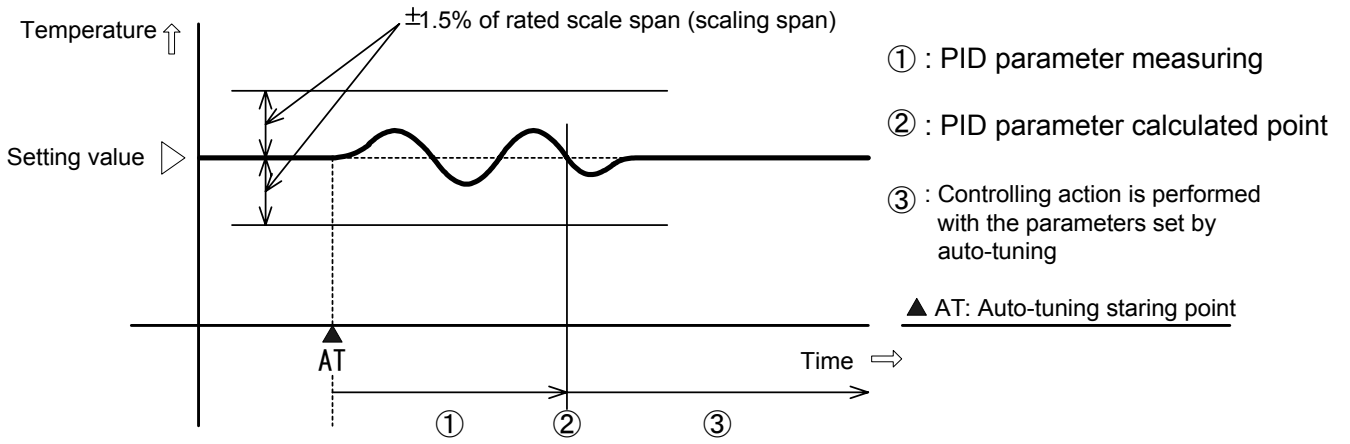

[Fig. 8.3-2]

[In case control temperature is 1.5% or greater of scaling span higher than the setting value.]

Fluctuation is given at the temperature 1.5% of scaling span higher than the setting value.

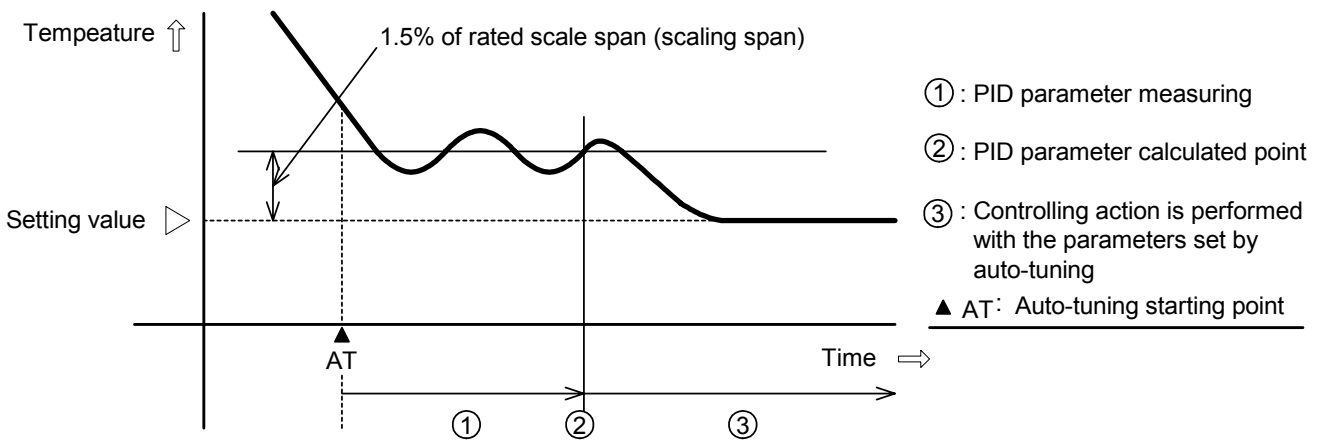

[Fig. 8.3-3]

8.4 Standard action drawings

Action	Heating (reverse) action			Cooling (direct) action		
Control action						
PC-935						
Relay contact output						
Non-contact voltage output						
Current output						
Indicator [OUT1] Green						
PC-955						
Open output Terminal ⑤—⑥						
Closed output Terminal ⑤—⑦						
Indicator [OUT1] Green						
Indicator [OUT2] Yellow						

(*1) Cycle action is performed according to deviation.

(*2) Changes continuously according to deviation.

8.5 ON/OFF action drawings

Action	Heating (reverse) action		Cooling (direct) action	
Control action				
PC-935				
Relay contact output				
Non-contact voltage output				
Current output				
Indicator [OUT1] Green				
PC-955				
Open output Terminal ⑤ — ⑥				
Closed output Terminal ⑤ — ⑦				
Indicator [OUT1] Green				
Indicator [OUT2] Yellow				

Part: Acts ON or OFF.

8.6 Heating/Cooling action drawings [Option DR, DS or DA] (only for PC-935 type)

Control output (OUT1): Heating (Reverse) action, Control output (OUT2): Cooling (Direct) action

Control action	ON	Control output OUT1, P-band	Control output OUT2, P-band	
	OFF			
		Setting		
Control output (OUT1, line ———)				
Relay contact output	H ④ C ⑤ L ⑥	H ④ C ⑤ L ⑥ (*1)	H ④ C ⑤ L ⑥	
Non-contact voltage output	⑤ — + ⑥ — - 12Vdc	⑤ — + ⑥ — - 12/0Vdc (*1)	⑤ — + ⑥ — - 0Vdc	
Current output	⑤ — + ⑥ — - 20mAdc	⑤ — + ⑥ — - 20 to 4mAdc (*2)	⑤ — + ⑥ — - 4mAdc	
Indicator [OUT1] Green	Lit			Unlit
Control output (OUT2, line - - - - -)				
Relay contact output		⑦ ⑧ (*1)	⑦ ⑧ (*1)	⑦ ⑧
Non-contact voltage output		⑦ — + ⑧ — - 0Vdc	⑦ — + ⑧ — - 0/12Vdc (*1)	⑦ — + ⑧ — - 12Vdc
Current output		⑦ — + ⑧ — - 4mAdc	⑦ — + ⑧ — - 4 to 20mAdc (*2)	⑦ — + ⑧ — - 20mAdc
Indicator [OUT2] Yellow	Unlit			Lit

(*1) Cycle action is performed according to deviation.

(*2) Changes continuously according to deviation.

Control output (OUT1): Cooling (Direct) action, Control output (OUT2): Heating (Reverse) action

Control action	ON	Control output OUT2, P-band		Control output OUT1, P-band
	OFF			
Control output (OUT1, line —————)				
Relay contact output			 (*1)	
Non-contact voltage output		 0Vdc	 0/12Vdc	 12Vdc
Current output		 4mA _{dc}	 4 to 20mA _{dc}	 20mA _{dc}
Indicator [OUT1] Green	Unlit			Lit
Control output (OUT2, line - - - - -)				
Relay contact output		 (*1)		
Non-contact voltage output	 12Vdc	 12/0Vdc	 0Vdc	
Current output	 20mA _{dc}	 20 to 4 mA _{dc}	 4mA _{dc}	
Indicator [OUT2] Yellow	Lit			Unlit

(*1) Cycle action is performed according to deviation.

(*2) Changes continuously according to deviation.

When setting Dead band

Action	Control output (OUT1)			Control output (OUT2)		
Control action						
Relay contact output		 (*1)			 (*1)	
Non-cotact voltage output		 (*1)			 (*1)	
Current output		 (*2)			 (*2)	
Indicator [OUT1] Green						
Indicator [OUT2] Yellow						

part: Acts ON or OFF.

(*1) Cycle action is performed according to deviation.

(*2) Changes continuously according to deviation.

When setting the Overlap band with Relay contact output

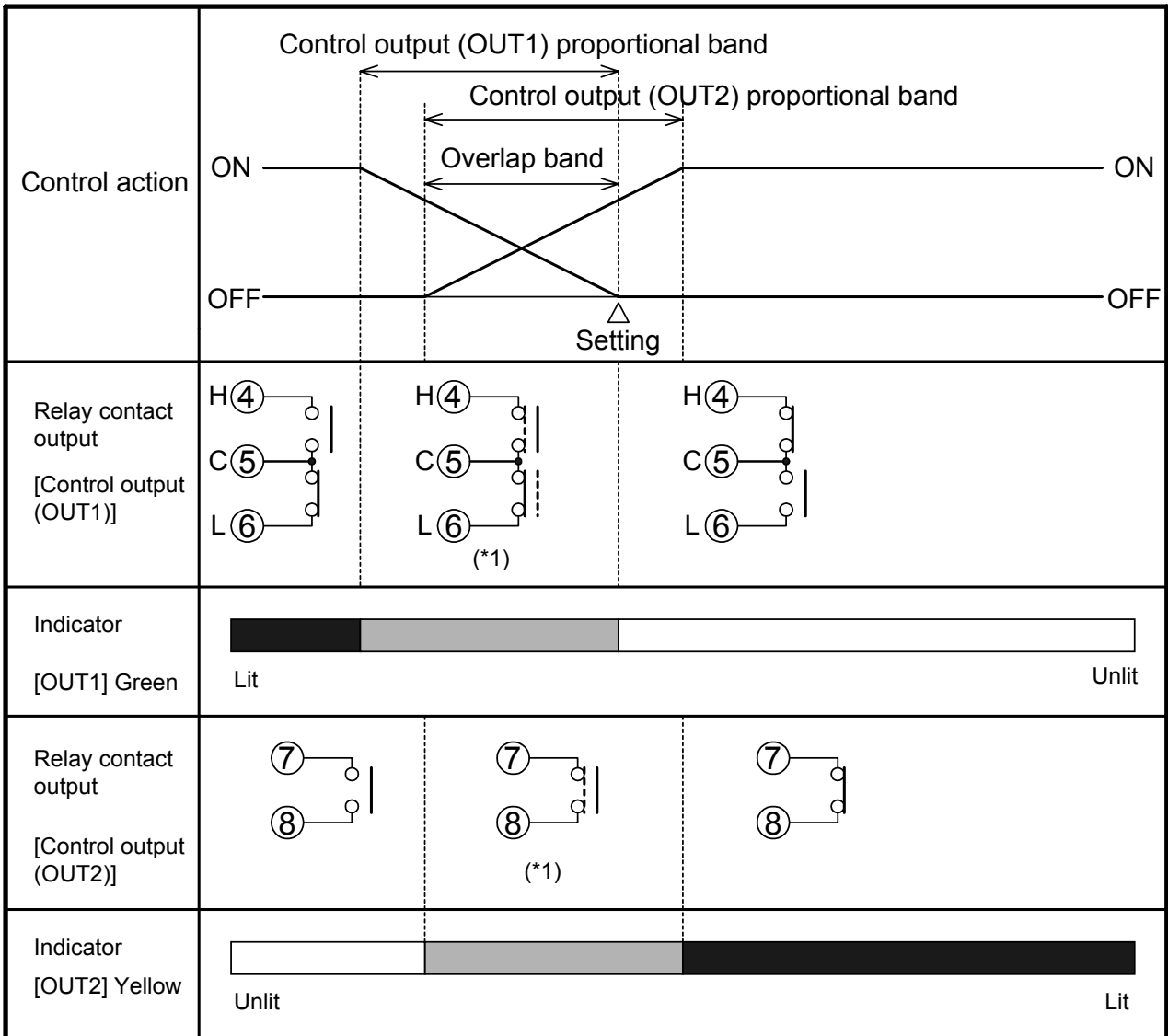

Part: Acts ON or OFF.

(*1) Cycle action is performed according to deviation.

8.7 Action drawing when setting Open/Closed output dead band (only for PC-955)

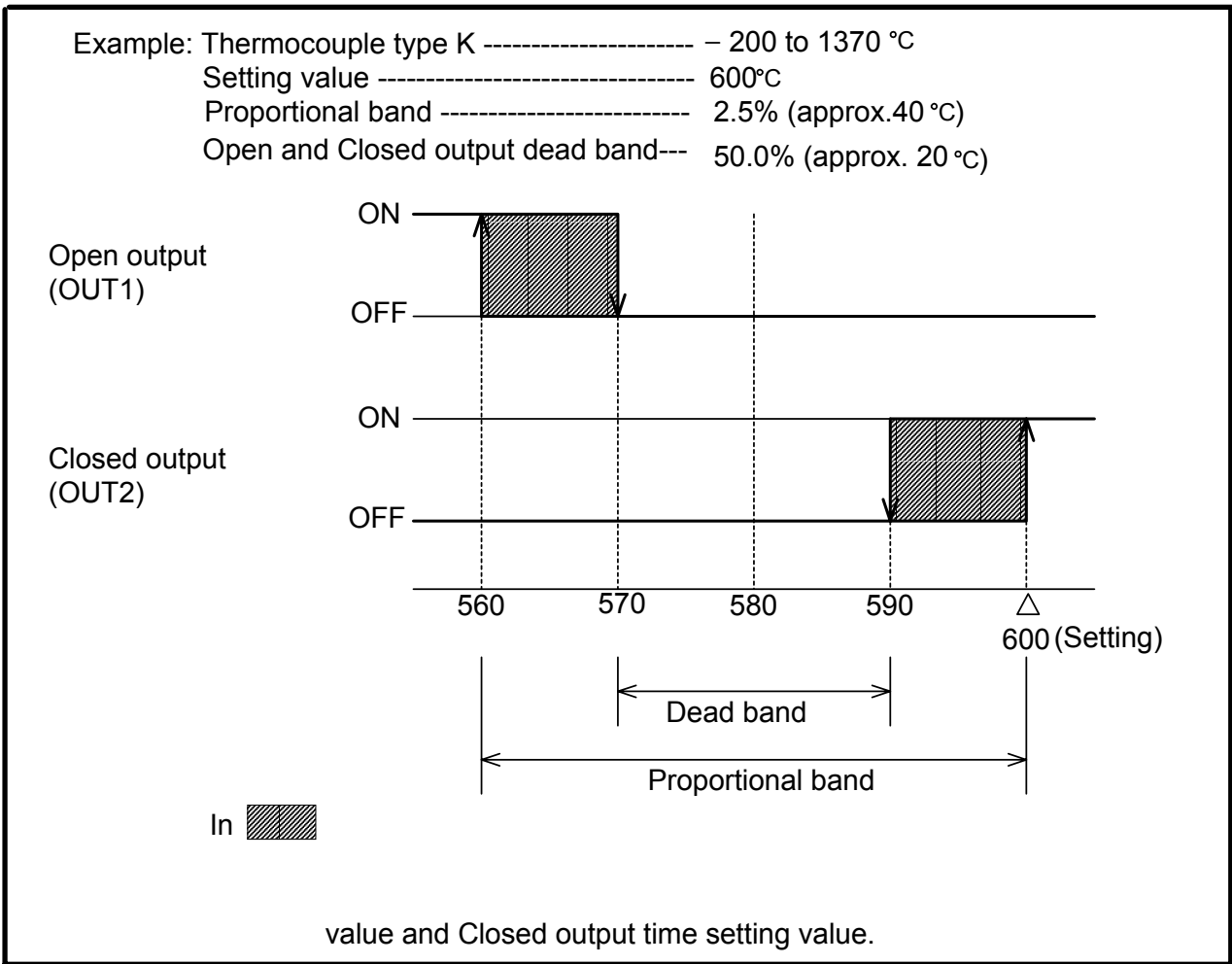

8.8 Pattern end action drawing

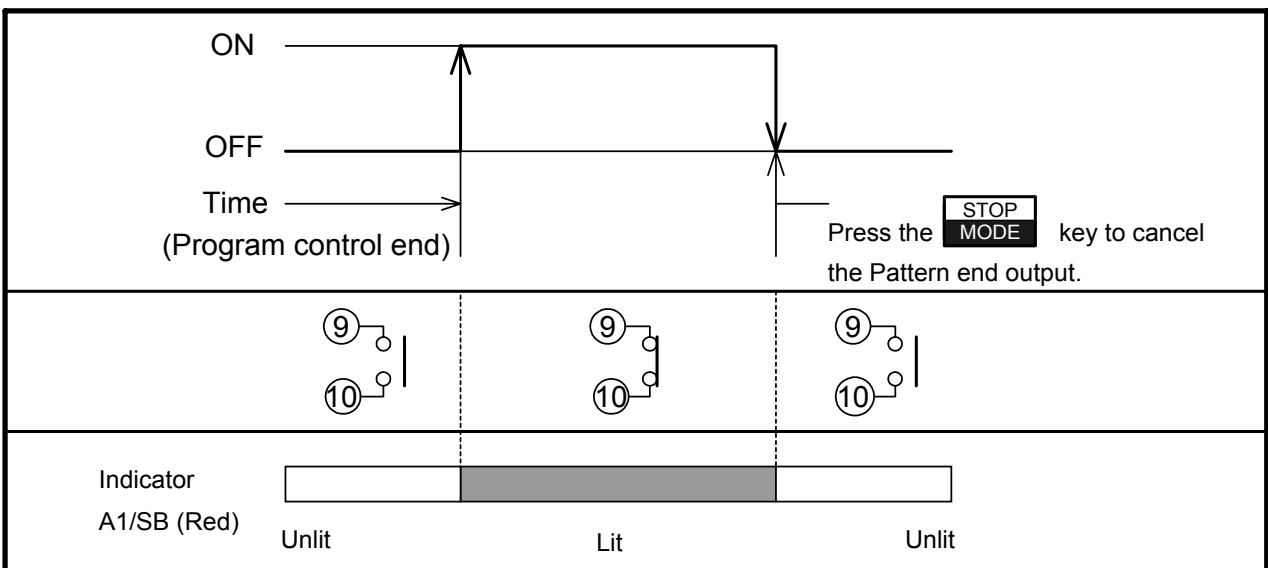

Pattern end output is turned ON when the Program control is finished.
 Pattern end output is not cancelled until the **STOP MODE** key is pressed.

8.9 Alarm 1 to 4 action drawings

	High limit alarm	Low limit alarm
Temperature alarm action		
Output		
Indication		
	High limit alarm w/standby	Low limit alarm w/standby
Temperature alarm action		
Output		
Indication		
	High/Low limits alarm	High/Low limit range alarm
Temperature alarm action		
Output		
Indication		

- Standby function works at [] part.
- ▲ and ▼ shows the action point of the alarm output.
- Output terminals for Alarm 2: ⑦ - ⑧ (only for PC-935)
 Alarm 3: ⑳ - ㉑, Alarm 4: ㉒ - ㉓

	High/Low limits alarm with standby	High/Low limit range alarm w/standby
Temperature alarm action		
Output		
Indication		
	Process high alarm	Process low alarm
Temperature alarm action		
Output		
Indication		
	Process high alarm w/standby	Process low alarm w/standby
Temperature alarm action		
Output		
Indication		

- Standby function works at [] part.
- ▲ and ▼ shows the action point of the alarm output.
- Output terminals for Alarm 2: ⑦ - ⑧ (only for PC-935)
Alarm 3: ⑳ - ㉑, Alarm 4: ㉒ - ㉓

9. Other functions

Burnout alarm

When the thermocouple or RTD is burnt out or the input value reaches [Rated scale maximum value +1% of rated scale span] or greater, PV display blinks [_ _ _ _] and it makes the control output off.

With the input RTD Pt100 (°F) or DC, the rated scale maximum value is 999.9 or 9999, if the input value is greater than the maximum value, PV display blinks [_ _ _ _], however, the control is performed to rated scale maximum value +1% of rated scale span.

When the input value falls [Rated scale minimum value -1% of rated scale span] or less, PV display blinks [_ _ _ _] and it makes the control output off.

With the input Thermocouple T, RTD or DC, the rated scale minimum value is -199.9 or -1999, if the input value is less than the minimum value, PV display blinks [_ _ _ _], however, the control is performed to rated scale minimum value -1% of rated scale span.

Self-diagnostic

It watches the CPU by watchdog timer, and when abnormal status on the CPU has been found, it makes the controller warm-up status.

Automatic cold junction temperature compensation (Thermocouple input type)

It detects the temperature at the connecting terminal between thermocouple and instrument, and always makes it the same status at which the reference junction is located at 0°C [32°F].

Warm-up indication

For approximately 2s after the power supplied to the instrument is turned on, the type of input and the unit are indicated on the PV display, and the maximum input rated value (in case of DC input, scaling high limit value) on the SV/MV/TIME display.

10. Specifications

10.1 Standard specifications

Name	: Digital Programmable Controller (PC-935 type) ON/OFF servo Digital Programmable Controller (PC-955 type)
Mounting method	: Flush
Setting	: Input system using membrane sheet key
Display	
PV display	: Red LED display 4 digits, size 14.3(H) x 8(W)mm
SV/MV/TIME display	: Green LED display 4 digits, size 10(H) x 5.5(W)mm
Pattern No. display	: Yellow LED display 1 digit, size 8(H) x 4(W)mm
Step No. display	: Green LED display 1 digit, size 8(H) x 4(W)mm
Input	
Thermocouple	: K, J, R, S, B, E, T [JIS, IEC], C (W/Re5-26) [ASTM], N (IEC) and PL-II (NBS) External resistance, 100 Ω or less When input burnout, Upscale
RTD	: Pt100 (JIS, IEC), JPt100 3-wire system Allowable input lead wire resistance, 10 Ω or less per wire When input burnout, Upscale
Current	: 0 to 20mAdc, 4 to 20mAdc Input impedance, 50 Ω When input burnout, 0 to 20mA, the same as 0mA 4 to 20mA, Downscale
Voltage	: 0 to 1Vdc Input impedance, 1M Ω or greater Allowable input voltage, 5V or less Allowable signal source resistance, 2k Ω or less When input burnout, Upscale
Input sampling period	: 0.125 seconds
Indicating or Setting accuracy	
Thermocouple input	: Within $\pm 0.2\%$ of input range full scale ± 1 digit, however, for R or S input, range 0 to 200 $^{\circ}\text{C}$ (400 $^{\circ}\text{F}$), within $\pm 4^{\circ}\text{C}$ (8 $^{\circ}\text{F}$). When B input, range 0 to 300 $^{\circ}\text{C}$ (600 $^{\circ}\text{F}$), without the range of accuracy guarantee. In case of K, J or T input, for less than 0 $^{\circ}\text{C}$ (32 $^{\circ}\text{F}$), within $\pm 0.4\%$ of input range full scale ± 1 digit (Cold junction compensating accuracy, $\pm 1^{\circ}\text{C}$, at 0 to 50 $^{\circ}\text{C}$)
RTD input	: Within $\pm 0.2\%$ of input range full scale ± 1 digit
Current input	: Within $\pm 0.2\%$ of input range full scale ± 1 digit
Voltage input	: Within $\pm 0.2\%$ of input range full scale ± 1 digit
Time indicating accuracy	: Within $\pm 0.1\%$ of setting time
Control output	
Relay contact	: 1a1b (for PC-955 type 1a x 2) Control capacity, 250Vac 3A (resistive load) 250Vac 1A (inductive load $\cos\phi=0.4$)
Non-contact voltage	: for SSR drive 12 $^{\pm 2}\%$ Vdc Maximum 40mAdc (short circuit protected)
Current	: 4 to 20mAdc (Isolated type) Load resistance, maximum 550 Ω

Alarm 1 (A1), 3 (A3) and 4 (A4) output

Deviation setting by \pm to main setting (excepting Process value alarm), and when the input exceeds the range the output turns ON or OFF (in case of High/Low range alarm).

Alarm action can be selected by internal switch or key operation.

- No alarm:
- High limit alarm (Deviation setting) : \pm input range span* (Off when set to 0)
- Low limit alarm (Deviation setting) : \pm input range span* (Off when set to 0)
- High/Low limits alarm (Deviation setting) : 0 to input range span* (Off when set to 0)
- High/Low limit range alarm (Deviation setting): 0 to input range span* (Off when set to 0)
- Process high alarm : input range minimum to input range maximum
- Process low alarm : input range minimum to input range maximum

*: For DC input, input range scaling span.

Standby function: Selectable

Setting accuracy : Within $\pm 0.2\%$ of input range full scale ± 1 digit

Action : ON/OFF action

Hysteresis setting range:

When thermocouple or RTD input, 0.1 to 100.0 $^{\circ}$ C ($^{\circ}$ F)

When DC input, 1 to 1000 (Decimal point place follows the selection.)

Output : Relay contact 1a (In case of [A3] or [A4], 1a x 2)

Control capacity

250Vac 3A (resistive load)

250Vac 1A (inductive load $\cos \phi=0.4$)

(However, A3 and A4 common terminal, Maximum 3A)

Controlling action

One of the actions Fuzzy overshoot suppressing PID action (with auto-tuning function) or PID action (with auto-tuning function) is selectable by DIP switch.

- Fuzzy overshoot suppressing PID action or PID action (with auto-tuning function)
 - Proportional band (P) : 0.0 to 999.9% (Setting the value to 0.0 causes the instrument to act as an ON/OFF controller.)
 - Integral time (I) : 0 to 3600 sec (Setting the value to 0 disables the function.)
 - Derivative time (D) : 0 to 1800 sec (Setting the value to 0 disables the function.)
 - Proportional cycle : 1 to 120 sec (Unavailable for the Current output type,)
 - Anti-reset windup (ARW) : 0 to 100%
 - Output limiter : 0 to 100% (In case of Current output, -5 to 105%)
 - Open output time setting : 0.1 to 999.9s (For PC-955 type)
 - Closed output time setting: 0.1 to 999.9s (For PC-955 type)
 - Hysteresis setting range : When thermocouple or RTD input, 0.1 to 100.0 $^{\circ}$ C ($^{\circ}$ F)
When DC input, 1 to 1000 (Decimal point place follows the selection.)

Supply voltage : 100 to 240Vac, 50/60Hz, 24Vac/dc, 50/60Hz (Specified)

Allowable voltage fluctuation: In case of 100 to 240Vac ---- 85 to 264Vac

In case of 24Vac/dc ----- 20 to 28Vac/dc

Ambient temperature : 0 to 50 $^{\circ}$ C (32 to 122 $^{\circ}$ F)

Ambient humidity : 35 to 85%RH (non-condensing)

Power consumption : Approx. 15VA

Circuit insulation configuration

[PC-935]

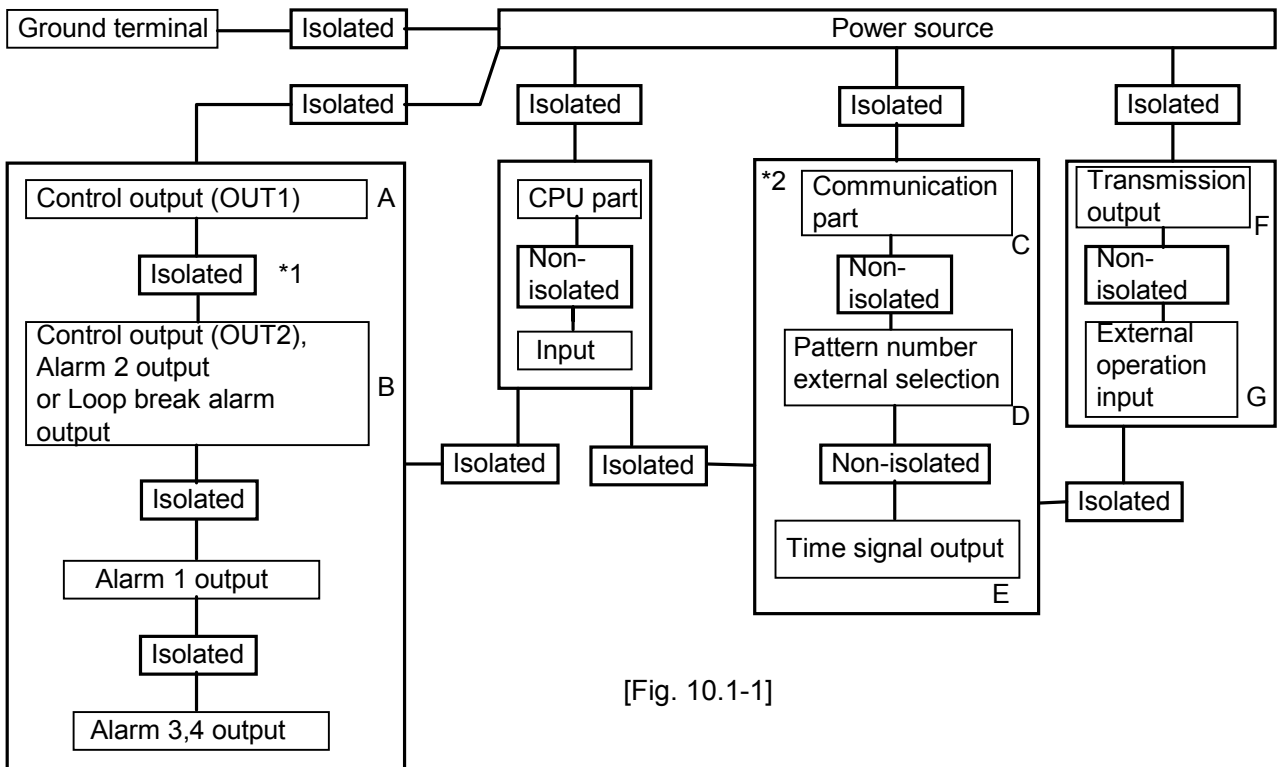

[Fig. 10.1-1]

(*1) In case both Control output (OUT1) and Control output (OUT2) are Current output type or Non-contact voltage output type, between A-B is non-isolated.

(*2) In case Control output (OUT1) is Current output type or Non-contact voltage output type, between A-C, A-D, A-E are non-isolated.

In case Control output (OUT2) is Current output type or Non-contact voltage output type, between B-C, B-D, B-E are non-isolated.

Insulation resistance

10MΩ or greater at 500Vdc

Insulation test **must not** be carried out,

between A-B in case of Circuit insulation configuration (*1),

between A-C, A-D, A-E, B-C, B-D, B-E, in case of (*2),

C-D-E and F-G because they are non-isolated.

Circuit insulation configuration

[PC-955]

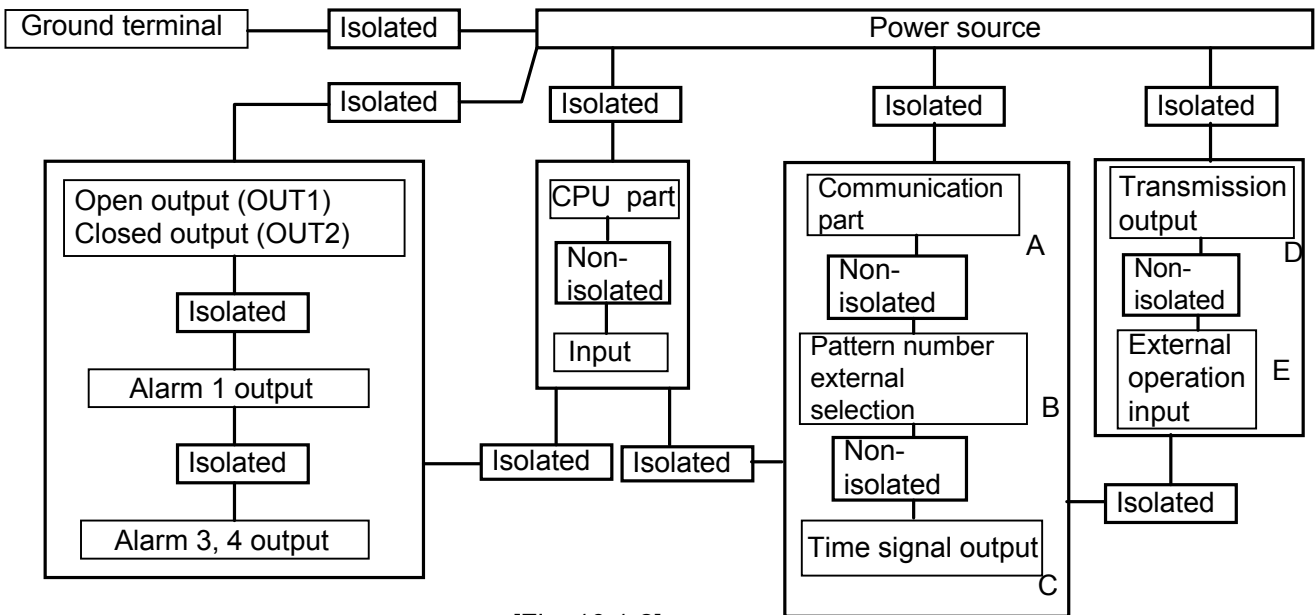

[Fig. 10.1-2]

Insulation resistance

10MΩ or greater at 500Vdc

Insulation test **must not** be carried out,

A-B-C and D-E because they are non-isolated.

Dielectric strength

Between input terminal and ground terminal, 1.5kVac for 1 minute

Between input terminal and power terminal, 1.5kVac for 1 minute

Between power terminal and ground terminal, 1.5kVac for 1 minute

Between output terminal and ground terminal, 1.5kVac for 1 minute

Between output terminal and power terminal, 1.5kVac for 1 minute

Weight : Approx. 500g

External dimension : 96 x 96 x 110mm (W x H x D)

Material : Base and Case, Flame resisting resin

Color : Base and Case, Light gray

Attached functions : Setting value lock, Setting value limit, Sensor correction, Multi-range, Multi-function, Alarm action delayed timer, Warm-up display, Wait, Hold, Advance, Back advance, Repeat, Link, Time fast progressing, Data clear, Pattern number external selection, External operation, Power failure compensation, Fixed value control, Self-diagnosis, Automatic cold junction temperature compensation, Sensor burnout function [upscale, downscale] and PV start.

Accessories :

- Mounting bracket 1 set
- Instruction manual 1 copy
- Unit nameplate 1 sheet
- Terminal cover 2 pieces [When option [TC] is applied.]
- Gasket 1 piece [When option [IP] is applied.]
- Auxiliary frame 1 piece [When option [IP] is applied.]

10.2 Optional specifications

Alarm output [A2] (only PC-935 type)

Deviation setting by \pm to main setting (excepting Process value alarm), and when the input exceeds the range the output turns ON or OFF (in case of High/Low range alarm).

Alarm action can be selected by internal switch.

When the option Alarm 2 output (A2) and Loop break alarm output (LA) are applied together, the output terminal is common.

Alarm 2 output (option code: A2) is not available with a combination of Heating/Cooling control output (option code: DR, DS or DA).

- No alarm action
- High limit alarm (Deviation setting) : \pm input range span* (Off when set to 0)
- Low limit alarm (Deviation setting) : \pm input range span* (Off when set to 0)
- High/Low limits alarm (Deviation setting) : 0 to input range span* (Off when set to 0)
- High/Low limit range alarm (Deviation setting): 0 to input range span* (Off when set to 0)
- Process high alarm : input range minimum to input range maximum
- Process low alarm : input range minimum to input range maximum

*: For DC input, input range scaling span.

Standby function: Selectable

Setting accuracy: Within $\pm 0.2\%$ of input range full scale ± 1 digit

Action : ON/OFF action

Hysteresis setting range:

When thermocouple or RTD input, 0.1 to 100.0 $^{\circ}$ C ($^{\circ}$ F)

When DC input, 1 to 1000 (Decimal point place follows the selection.)

Output : Relay contact 1a

Control capacity

250Vac 3A (resistive load)

250Vac 1A (inductive load $\cos\phi=0.4$)

Loop break alarm output [LA]

It detects the breaking status on the loop such as heater burnout, sensor burnout or the operation end trouble.

When Loop break alarm output (LA) and Alarm 2 output (A2) are applied together, the output terminal is common.

Loop break alarm output (LA) is not available with a combination of Heating/Cooling control output (DR, DS or DA).

In case of PC-955 type, relay contact output is not available. (However, the LA indicator lights.)

Setting range: Loop break alarm time setting, 0 to 200 minutes

Loop break alarm span setting, When TC (excepting T) or RTD input, 0 to 100 $^{\circ}$ C($^{\circ}$ F)

0.0 to 100.0 $^{\circ}$ C($^{\circ}$ F) (with decimal point)

When DC input, 1 to 1000 (Decimal point place follows the setting.)

Output : Relay contact 1a

Control capacity, 250Vac 3A (resistive load)

250Vac 1A (inductive load, $\cos\phi = 0.4$)

Heating/Cooling control output [DR, DS or DA] (only PC-935 type)

Heating/Cooling control output is not available with a combination of Alarm 2 output or Loop break alarm output.

The specifications of heating side are the same as Main control.

Cooling side proportional band : Multiplying factor to the control output (OUT1) proportional band is 0.0 to 10.0.

(ON/OFF action when set to 0.0)

Cooling side integral time : Integral time of control output (OUT1)

Cooling side derivative time : Derivative time of control output (OUT1)

Cooling side proportional cycle: 1 to 120sec. (Unavailable to the DC current output type.)

Overlap band/Dead band setting range:

\pm Heating proportional band value converted

Action : ON/OFF action

Hysteresis : When thermocouple or RTD input, 0.1 to 100.0°C(°F)

When DC input, 1 to 1000 (Decimal point place follows the selection.)

Cooling action mode selection function:

Air cooling ----- Linear characteristic

Oil cooling -----1.5th power of linear characteristic

Water cooling ----2nd power of linear characteristic

Output [DR] Relay contact 1a

Control capacity 250Vac 3A (resistive load)

250Vac 1A (inductive load $\cos\phi=0.4$)

[DS] Non-contact voltage (for SSR drive)

12⁺²₀Vdc Maximum 40mAdc (short circuit protected)

[DA] Current

4 to 20mAdc (Isolation type)

Load resistance, Maximum 550 Ω

Transmission output [TA or TV]

Any one of transmissions, Process variable, Main setting value or Main output manipulating value, is output in current or voltage, converting the value to analog signal every 0.125 seconds.

Transmitting parameter: PV, SV, MV (Selectable by key)

Resolution : 1/10000

Current (TA) : 4 to 20mAdc (load resistance, maximum 500 Ω)

Voltage (TV) : 0 to 1Vdc (load resistance, minimum 100k Ω)

Output accuracy : Within $\pm 0.3\%$ of full scale

Serial communication [C or C5]

Following operations can be executed from the external computer.

- Reading and setting of the Main setting value, PID value and various setting values.
- Reading of the input value and the action status.
- Change of the functions.

Communication circuit : Based on EIA RS-485 [Option code: C5] or
 Based on EIA RS-232C [Option code: C]

The number of units to be connected: RS-232C-----1 unit (Unable to connect in parallel)
 RS-485----- maximum 31 units (for PC-900)

Communication method : Half-duplex communication start-stop synchronous

Data transfer rate : 2400, 4800, 9600 and 19200bps (selectable by key operation)

Data format Start bit : 1
 Data bit : 7
 Parity : Even parity
 Stop bit : 1

Setting value digital transmission [SVTC]

If this option is designated adding the option C5 (RS-485), the main setting value can be transmitted in digital when combined with FCD or FCR applied the option C5.

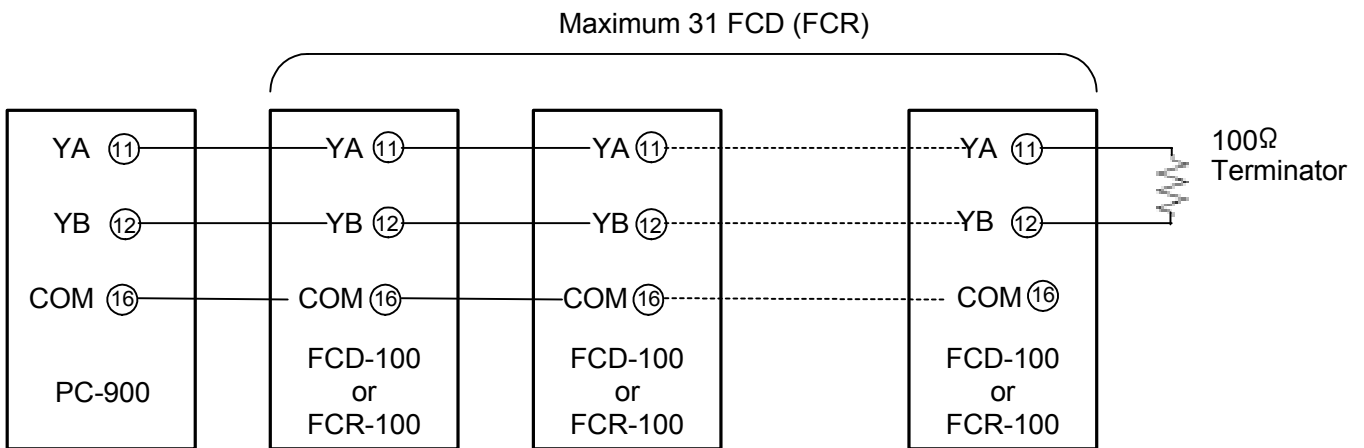

[Fig. 10.2-1]

Time signal output [TS]

Time signal block number (Block number that the OFF time and ON time of the signal were set) can be set to each step.

Maximum 8 channels per step can be output.

The time signal output is changeable to status output as shown below.

- Time signal output TS1 → RUN
- Time signal output TS2 → HOLD
- Time signal output TS3 → WAIT
- Time signal output TS4 → FAST
- Time signal output TS5 → STOP

Number of circuit : 8

Output : Open collector, Capacity 24Vdc maximum 50mA

Color black [BK]

- Front panel : Dark gray
- Case : Black

Terminal cover [TC]

Electrical shock protecting terminal cover

Dust-proof • Drip-proof [IP]

Drip-proof and Dust-proof specification (IP54)

- Effective to only panel surface, case part is excluded.

It is recommended to use Front cover (soft type, sold separately) to strengthen the Dust-proof and Drip-proof function.

- To protect the controller from water leak between control panel and controller, make notes of the following items.

- ① The panel cutout dimension should be proper and no burrs.
- ② The control panel surface to be mounted should be vertical.

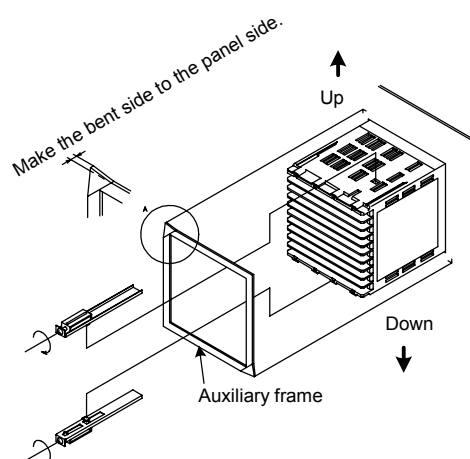

[Fig. 10.2-2]

Specified specifications

- Input range : Shipped as specified range.
- Alarm action : Shipped as specified alarm action. (e.g. A1, A2, A3, A4)
- Cooling action mode: Shipped as specified action mode. (e.g. for the option DR, DS or DA)
- Transmission output: Shipped as specified output. (e.g. for the option TA or TV)

11. When troubled

When troubled, refer to the following items after checking the power and the wiring.



Warning

Turn the power supplied to the instrument **OFF** before wiring or checking. If working or touching the terminal with the power **ON** status, there is a possibility of **Electric Shock** which can cause severe injury or death.

Moreover, the instrument must be grounded before the power supplied to the instrument is turned on.

[Indication]

- Phenomenon: PV display blinks [- - - -].

Presumed cause	Action
<ul style="list-style-type: none"> • Thermocouple or RTD burnout • Lead wire of thermocouple or RTD is not surely mounted. 	<ul style="list-style-type: none"> • Exchange the Thermocouple or RTD. [In case of Thermocouple] If the input terminal of the instrument is shorted, and if nearby room temperature is indicated, the instrument should be normal and sensor may be broken. • [In case of RTD] If approx. 100Ω of resistance is connected to the Input terminal between A-B of the instrument and between B-B is shorted, and if nearby 0℃(F) is indicated, the instrument should be normal, and sensor may be broken. • Surely connect the lead wire.

- Phenomenon: PV display blinks [- - - -].



Presumed cause	Action
<ul style="list-style-type: none"> • Codes (A, B, B) of RTD does not agree with the instrument terminal. • Polarity of thermocouple or compensation lead wire is reverse. 	<ul style="list-style-type: none"> • Connect the wire properly. • Connect the wire properly.

- Phenomenon: Indication on PV display is abnormal or unstable.



Presumed cause	Action
<ul style="list-style-type: none"> • Designation of the Sensor input is improper. • The temperature unit (℃ or ℉) is mistaken. • Sensor correcting value is unsuitable. 	<ul style="list-style-type: none"> • Set the Sensor input properly by Rotary switch and DIP switch. (page 11) • Set the unit properly by DIP switch. (page 10) • Set the value suitably. (page 61)

Presumed cause	Action
<ul style="list-style-type: none"> • Specification of Thermocouple or RTD is improper. • AC leaks into thermocouple or RTD circuit. • There is an apparatus to send out inductive interference or noise near the controller. 	<ul style="list-style-type: none"> • Make the specification properly, the sensor to the instrument or the instrument to the sensor. • Use isolated type of thermocouple. • Keep the instrument away from the apparatus which sends out inductive interference or noise.

[Key operation]



- **Phenomenon: Main setting value, PID values, Proportional cycle value and Alarm 1 to 4 cannot be set. (Values cannot be changed by the  or  key.)**

Presumed cause	Action
<ul style="list-style-type: none"> • Setting value lock is designated. • During PID auto-tuning. 	<ul style="list-style-type: none"> • Release the lock designation. (page 67) • Cancel the tuning if necessary. (page 89)

- **Phenomenon: Even if the  or  key is pressed, the setting indication does not change over or under in the rated scale range, therefore the settings are impossible.**

Presumed cause	Action
<ul style="list-style-type: none"> • Main setting value high limit or low limit may be set at the point the value cannot be changed. 	<ul style="list-style-type: none"> • Set the limit value again to appropriate value. (page 55)



- **Phenomenon: Program does not start even if the  key is pressed in Program mode.**

Presumed cause	Action
<ul style="list-style-type: none"> • External operation STOP is working. 	<ul style="list-style-type: none"> • Open the terminal between  and . (page 83)

- **Phenomenon: Program is finished in a moment.**

Presumed cause	Action
<ul style="list-style-type: none"> • Step time is not set. 	<ul style="list-style-type: none"> • Set the step time. (page 22)

- **Phenomenon: Step does not move.**

Presumed cause	Action
<ul style="list-style-type: none"> • Status is in HOLD. • WAIT action is working. 	<ul style="list-style-type: none"> • Press the  key to perform the program control again. (page 83) • Press the  or  key to cancel Wait function. (page 34, 84)

[Control]

- **Phenomenon: Process variable (PV) does not rise.**

Presumed cause	Action
<ul style="list-style-type: none"> • Thermocouple or RTD burnout • Thermocouple or RTD is not surely mounted (inserted) to the control object. 	<ul style="list-style-type: none"> • Exchange the Thermocouple or RTD. • Surely mount (insert) the Thermocouple or RTD to the control object.

- **Phenomenon: Process variable (PV) rises too much.**

Presumed cause	Action
<ul style="list-style-type: none"> • Specification of the Thermocouple or RTD is improper. 	<ul style="list-style-type: none"> • Make the specification properly, the sensor to the instrument or the instrument to the sensor.

- **Phenomenon: Fixed value control is not performed.**

Presumed cause	Action
<ul style="list-style-type: none"> • Program mode is selected. 	<ul style="list-style-type: none"> • Change the mode to Fixed value control. (page 85)

- **Phenomenon: Output is kept its ON status.**

Presumed cause	Action
<ul style="list-style-type: none"> • Control output (OUT1) low limit value or Control output (OUT2) low limit value is set to 100% or greater in the Block setting mode (Output block). 	<ul style="list-style-type: none"> • Set the value appropriately. (page 49, 51)

- **Phenomenon: Output is kept its OFF status.**

Presumed cause	Action
<ul style="list-style-type: none"> • Control output (OUT1) high limit value or Control output (OUT2) high limit value is set to 0% or less in the Block setting mode (Output block). 	<ul style="list-style-type: none"> • Set the value appropriately. (page 49, 51)

If happened unclear phenomenon other than above mentioned, make inquiries about the matters at our agency or your shop where purchased.

12. Initial values

[program control]

• Pattern setting mode [Pfn.]

PV display	Setting item	Initial value (SV, MV, TIME display)	Memo
Pfn	Pattern number selection	0	
TEMP	Step temperature setting	0℃	
TIME	Step time setting	00.00 min	
_PID	PID block number setting	0	
_F41	Time signal 1 block number	0	
_F42	Time signal 2 block number	0	
_F43	Time signal 3 block number	0	
_F44	Time signal 4 block number	0	
_F45	Time signal 5 block number	0	
_F46	Time signal 6 block number	0	
_F47	Time signal 7 block number	0	
_F48	Time signal 8 block number	0	
_WR	Wait block number	0	
_AL	Alarm block number	0	
_OUT	Output block number	0	

• Block setting mode [PAct.]

* PID block [P_00] (In case of the PID block number 0)

PO_P	Proportional band (OUT1)	2.5%	
PO_I	Integral time	200sec	
PO_d	Derivative time	50sec	
PO_n	Anti-reset windup	50%	
POPb	Proportional band (OUT2)	1.0 (Multiplying factor)	

* Time signal block [F_00] (In case of the Time signal block number 0)

OO_F	Time signal output OFF time	00.00 min	
OO_n	Time signal output ON time	00.00 min	

* Wait block [W_00] (In case of the Wait block number 0)

WO_	Wait value setting	0℃	
-----	--------------------	----	--

* Alarm block [R_00] (In case of the Alarm block number 0)

RO_1	Alarm 1 (A1) action point	0℃	
RO_2	Alarm 2 (A2) action point	0℃	
RO_3	Alarm 3 (A3) action point	0℃	
RO_4	Alarm 4 (A4) action point	0℃	

* Output block [o_00] (In case of the Output block number 0)

PV display	Setting item	Initial value (SV, MV, TIME display)	Memo
o0_H	Control output (OUT1) high limit	100%	
o0_L	Control output (OUT1) low limit	0%	
o0Hb	Control output (OUT2) high limit	100%	
o0Lb	Control output (OUT2) low limit	0%	
o0cL	Changing rate limit (OUT1)	0%	

• Number of repeat, Pattern link designation mode [cHi_n]

rEPF	Number of repeat (Pattern No. 0)	0	
cHi_n	Pattern link (Pattern No. 0 and 1)	----: No link	

• PID auto-tuning performing mode [RF. . .]

RF4	Auto-tuning action	noL: Normal mode	
RF	Auto-tuning Performance/Cancellation	----: Cancellation	

• Attached function setting mode [c.o.n.d]

* Alarm parameter setting mode [ALn.]

AL3F	Alarm 3 (A3) action form	H: High limit alarm	
AL4F	Alarm 4 (A4) action form	L: Low limit alarm	
A1HY	Alarm 1 (A1) hysteresis	1.0℃	
A2HY	Alarm 2 (A2) hysteresis	1.0℃	
A3HY	Alarm 3 (A3) hysteresis	1.0℃	
A4HY	Alarm 4 (A4) hysteresis	1.0℃	
A1dY	Alarm 1 (A1) delayed timer	0 sec	
A2dY	Alarm 2 (A2) delayed timer	0 sec	
A3dY	Alarm 3 (A3) delayed timer	0 sec	
A4dY	Alarm 4 (A4) delayed timer	0 sec	
LP_r	Loop break alarm time	0 min	
LP_H	Loop break alarm span	0℃	

* Output parameter setting mode [OUT.]

PV display	Setting item	Initial value (SV, MV, TIME display)	Memo
c	Proportional cycle (OUT1)	R/M: 30 sec, S/M: 3 sec	
HY4	ON/OFF action hysteresis (OUT1)	1.0°C	
c_b	Proportional cycle (OUT2)	DR: 30 sec, DS: 3 sec	
cRef	Cooling action selection (OUT2)	Air: Air cooling	
HY4b	ON/OFF action hysteresis (OUT2)	1.0°C	
db	Overlap band/Dead band setting	0.0%	
P_db	Open/Closed output dead band	3.0%	
Pof	Open output time setting	30 sec	
Pcf	Closed output time setting	30 sec	

* Main setting value limit setting mode [HL/LA]

4H	Main setting value high limit	1370°C	
4L	Main setting value low limit	-200°C	

* Transmission output parameter setting mode [FRO.]

FRO4	Transmission output	PR: PV	
FRLH	Transmission output high limit	1370°C	
FRLl	Transmission output low limit	-200°C	

* Input parameter setting mode [IAP.]

4FLH	Scaling high limit	9999	
4FLl	Scaling low limit	-1999	
dP	Decimal point place	. : No decimal point	
4o	Sensor correction	0.0°C	
FILF	PV filter time constant	0.0 sec	

* Communication parameter setting mode [CAQA]

CA4P	Communication transfer rate	95: 9600bps	
CA4o	Instrument number	0	
CA4	Communication mode	4o4L: Serial communication	

* Other function setting mode [oF.E.r.]

PV display	Setting item	Initial value (SV, MV, TIME display)	Memo
Lock	Setting value lock selection	----: Lock cancelled	
4.48	Step temperature setting value when program control start	0.0℃	
4.4L	Program control starting system	PB: PV start	
PrEL	Status after power failure restored selection	conf: Continuation	
ā.4	Step time unit selection	ā/ā: Minute	
4.7ā	Step time indicating method	rF: Remaining time	
4.7E	Step temperature indication	48: Setting value corresponds to time progress	
PEFā	Pattern end output time setting	0 sec	
PEH	Step temperature setting value holding function when Program completed	4FOP: Stop	
F4.14	Time signal 1 output or Status output (RUN) selection	F4: Time signal 1	
F4.24	Time signal 2 output or Status output (HOLD) selection	F4: Time signal 2	
F4.34	Time signal 3 output or Status output (WAIT) selection	F4: Time signal 3	
F4.44	Time signal 4 output or Status output (FAST) selection	F4: Time signal 4	
F4.54	Time signal 5 output or Status output (STOP) selection	F4: Time signal 5	
o4F	Overshoot suppression factor	1.0	
EoUF	Output selection when the input burnout	oFF: Makes the control output OFF	

• Automatic/Manual control changing mode [āRāU]

āRāU	Automatic/Manual control change	āUFā: Automatic	
------	---------------------------------	-----------------	--

[Fixed value control]

• Fixed value control parameter setting mode [F.V.]

* Main setting value (SV) setting mode [4 . . .]

4	Main setting value (SV) setting	0℃	
---	---------------------------------	----	--

* PID parameter setting mode [P.I.d.]

P	Proportional band (OUT1)	2.5%	
I	Integral time	200 sec	
d	Derivative time	50 sec	
ā	Anti-reset windup	50%	
Pb	Proportional band (OUT2)	1.0 (multiplying factor)	

* Alarm action point setting mode [R . . .]

R1	Alarm 1 action point setting	0℃	
R2	Alarm 2 action point setting	0℃	
R3	Alarm 3 action point setting	0℃	
R4	Alarm 4 action point setting	0℃	

• PID auto-tuning performing mode [Rf . .]

PV display	Setting item	Initial value (SV, MV, TIME display)	Memo
Rf4	Auto-tuning action	noAL: Normal mode	
Rf	Auto-tuning performance/cancellation	----: Cancellation	

• Attached function setting mode [c.o.n.d.]

* Alarm parameter setting mode [AL.A.]

AL3F	Alarm 3 (A3) action form	H: High limit alarm	
AL4F	Alarm 4 (A4) action form	L: Low limit alarm	
A1HY	Alarm 1 (A1) hysteresis	1.0℃	
A2HY	Alarm 2 (A2) hysteresis	1.0℃	
A3HY	Alarm 3 (A3) hysteresis	1.0℃	
A4HY	Alarm 4 (A4) hysteresis	1.0℃	
A1dY	Alarm 1 (A1) delayed timer	0 sec	
A2dY	Alarm 2 (A2) delayed timer	0 sec	
A3dY	Alarm 3 (A3) delayed timer	0 sec	
A4dY	Alarm 4 (A4) delayed timer	0 sec	
LP_f	Loop break alarm time	0 min	
LP_H	Loop break alarm span	0℃	

* Output parameter setting mode [o.u.f. .]

c	Proportional cycle (OUT1)	R/M: 30 sec, S/M: 3 sec	
oLH	Control output (OUT1) high limit	100%	
oLL	Control output (OUT1) low limit	0%	
HY4	ON/OFF action hysteresis (OUT1)	1.0℃	
orRf	Changing rate limit (OUT1)	0%	
c_b	Proportional cycle (OUT2)	DR: 30 sec, DS: 3 sec	
cRcf	Cooling action selection (OUT2)	Air c: Air cooling	
oLHb	Control output (OUT2) high limit	100%	
oLLb	Control output (OUT2) low limit	0%	
HY4b	ON/OFF action hysteresis (OUT2)	1.0℃	
db	Overlap band/Dead band setting	0.0%	
P_db	Open/Closed output dead band	3.0%	
Pof	Open output time setting	30 sec	
Pcf	Closed output time setting	30 sec	

* Main setting value limit setting mode [H.L.L.A.]

H	Main setting value high limit	1370℃	
L	Main setting value low limit	-200℃	

* Transmission output parameter setting mode [*f.r.o.*]

PV display	Setting item	Initial value (SV, MV, TIME display)	Memo
<i>froh</i>	Transmission output	<i>PV</i> : PV	
<i>frlh</i>	Transmission output high limit	1370°C	
<i>frll</i>	Transmission output low limit	-200°C	

* Input parameter setting mode [*i.n.p.*]

<i>4flh</i>	Scaling high limit	9999	
<i>4fll</i>	Scaling low limit	-1999	
<i>dp</i>	Decimal point place	. : No decimal point	
<i>to</i>	Sensor correction	0.0°C	
<i>filf</i>	PV filter time constant	0.0 sec	

* Communication parameter setting mode [*c.o.n.*]

<i>cn4p</i>	Communication transfer rate	<i>96</i> : 9600bps	
<i>cnno</i>	Instrument	0	
<i>cn4</i>	Communication mode	<i>no4</i> : Serial communication	

* Other function setting mode [*o.f.f.r.*]

<i>lock</i>	Setting value lock selection	<i>----</i> : Lock cancelled	
<i>eof</i>	Output selection when the input burnout	<i>off</i> : Makes the control output OFF	

• Automatic/Manual control changing mode [*ā.r.n.u.*]

<i>ā.r.n.u.</i>	Automatic/Manual control change	<i>āuf</i> : Automatic	
-----------------	---------------------------------	------------------------	--

Index 1 (Program control)

[Program setting mode]

• Pattern number setting ----- 22	• Time signal block number selection ----- 22
• Step temperature setting ----- 22	• Wait block number selection ----- 23
• Step time setting ----- 22	• Alarm block number selection ----- 23
• PID block number selection ----- 22	• Output block number selection ----- 23

[Block setting mode]

PID block data setting		Alarm block data setting	
• Control output (OUT1) proportional band ----- 26	• Integral time setting ----- 27	• Alarm 1 (A1) action point setting ----- 36	• Alarm 2 (A2) action point setting ----- 36
• Derivative time setting ----- 27	• Anti-reset windup setting ----- 27	• Alarm 3 (A3) action point setting ----- 36	• Alarm 4 (A4) action point setting ----- 36
• Control output (OUT2) proportional band ----- 27		Output block data setting	
Time signal block data setting		• Control output (OUT1) high limit setting ----- 39	
• Time signal output OFF time setting -- 30	• Time signal output ON time setting --- 30	• Control output (OUT1) low limit setting ----- 39	
Wait block data setting		• Control output (OUT2) high limit setting ----- 39	
• Wait value setting ----- 33		• Control output (OUT2) low limit setting ----- 39	
		• Control output (OUT1) changing rate limit setting ----- 40	

[Number of repeat, Pattern link setting mode]

• Number of repeat of pattern setting --- 42
• Pattern link setting ----- 42

[PID auto-tuning performing mode]

• PID auto-tuning action selection ----- 90
• PID auto-tuning performance/cancellation ----- 91

[Attached function setting mode]

Alarm parameter setting

- Alarm 3 (A3) action form selection ----- 44
- Alarm 4 (A4) action form selection ----- 45
- Alarm 1 to 4 (A1 to A4) hysteresis setting ---- 45
- Alarm 1 to 4 (A1 to A4) delayed timer setting -46
- Loop break alarm time setting ----- 47
- Loop break alarm span setting ----- 47

Output parameter setting

- Control output (OUT1)
 - Proportional cycle setting ----- 49
- Control output (OUT1)
 - ON/OFF hysteresis setting ----- 50
- Control output (OUT2)
 - proportional cycle setting ----- 50
- Control output (OUT2)
 - action selection -----50
- Control output (OUT2)
 - ON/OFF hysteresis setting ----- 51
- Overlap band/Dead band setting ----- 51
- Open/Closed output dead band setting ----- 52
- Open output time setting -----52
- Closed output time setting -----52

Main setting value limit setting

- Main setting value
 - high limit setting ----- 55
- Main setting value
 - low limit setting ----- 55

Transmission output parameter setting

- Transmission output selection ----- 57
- Transmission output high limit setting ----- 57
- Transmission output low limit setting ----- 58

Input parameter setting

- Scaling high limit value setting -----60
- Scaling low limit value setting -----60
- Decimal point place selection ----- 61
- Sensor correction setting -----61
- PV filter time constant setting ----- 61

Communication parameter setting

- Communication transfer rate selection ----- 64
- Instrument number setting ----- 64
- Communication mode selection ----- 65

Other functions setting

- Setting value lock selection ----- 67
- Step temperature setting value (SV)
 - [when program control start] setting -----67
- Program control starting system selection ---- 67
- Status after power failure restored selection -- 68
- Step time unit selection ----- 68
- Step time indicating method selection ----- 69
- Step temperature indicating method selection 69
- Pattern end output time setting ----- 69
- Step temperature setting value (SV) when
 - program end holding function selection ----- 70
- Time signal 1 output/Status output (RUN)
 - selection ----- 70
- Time signal 2 output/Status output (HOLD)
 - selection -----71
- Time signal 3 output/Status output (WAIT)
 - selection ----- 71
- Time signal 4 output/Status output (FAST)
 - selection ----- 72
- Time signal 5 output/Status output (STOP)
 - selection ----- 72
- Overshoot suppression factor setting ----- 73
- Output selection when the input burnout ----- 73

[Auto/Manual control changing mode]

- Auto/Manual control changing ----- 86

Index 2 (Fixed value control)

[Fixed value control parameter setting mode]

<p>Main setting value (SV) setting</p> <ul style="list-style-type: none"> • Main setting value setting ----- 75 <p>PID parameter setting</p> <ul style="list-style-type: none"> • Control output (OUT1) proportional band ----- 76 • Integral time setting ----- 76 • Derivative time setting ----- 77 • Anti-reset windup setting ----- 77 • Control output (OUT2) proportional band ----- 77 	<p>Alarm action point setting</p> <ul style="list-style-type: none"> • Alarm 1 (A1) action point setting ----- 78 • Alarm 2 (A2) action point setting ----- 79 • Alarm 3 (A3) action point setting ----- 79 • Alarm 4 (A4) action point setting ----- 79
---	---

[PID auto-tuning performing mode]

<ul style="list-style-type: none"> • PID auto-tuning action selection ----- 90 • PID auto-tuning performance/cancellation --- 91
--

[Attached function setting mode]

<p>Alarm parameter setting</p> <ul style="list-style-type: none"> • Alarm 3 (A3) action form selection - ----- 44 • Alarm 4 (A4) action form selection ----- 45 • Alarm 1 to 4 (A1 to A4) hysteresis setting ---45 • Alarm 1 to 4 (A1 to A4) delayed timer setting 46 • Loop break alarm time setting -----47 • Loop break alarm span setting ----- 47 <p>Output parameter setting</p> <p>Control output (OUT1)</p> <ul style="list-style-type: none"> • proportional cycle setting ----- 49 • high limit setting ----- 49 • low limit setting ----- 49 • ON/OFF hysteresis setting ----- 50 • changing rate limit setting ----- 50 <p>Control output (OUT2)</p> <ul style="list-style-type: none"> • proportional cycle setting ----- 50 • action selection ----- 50 • high limit setting ----- 51 • low limit setting ----- 51 • ON/OFF hysteresis setting ----- 51 • Overlap band/Dead band setting ----- 51 • Open/Closed output dead band setting ----- 52 • Open output time setting ----- 52 • Closed output time setting ----- 52 	<p>Main setting value limit setting</p> <ul style="list-style-type: none"> • Main setting value high limit setting ----- 55 • Main setting value low limit setting ----- 55 <p>Transmission output parameter setting</p> <ul style="list-style-type: none"> • Transmission output selection ----- 57 • Transmission output high limit setting ----- 57 • Transmission output low limit setting ----- 58 <p>Input parameter setting</p> <ul style="list-style-type: none"> • Scaling high limit value setting ----- 60 • Scaling low limit value setting ----- 60 • Decimal point place selection ----- 61 • Sensor correction setting ----- 61 • PV filter time constant setting ----- 61 <p>Communication parameter setting</p> <ul style="list-style-type: none"> • Communication transfer rate selection ----- 64 • Instrument number setting ----- 64 • Communication mode selection ----- 64 <p>Other functions setting</p> <ul style="list-style-type: none"> • Setting value lock selection ----- 67 • Output selection when the input burnout ----- 73
---	--

[Auto/Manual control changing mode]

<ul style="list-style-type: none"> • Auto/Manual control changing ----- 86

Program pattern graphing

Graph the Program pattern and make the Data sheet before setting the Program. (Refer to page 126)
Copy the Program pattern sheet (Page 131) and graph the pattern by following procedure.

- Enter the temperature on vertical axis including the highest and lowest temperature to be used.
- Enter the step temperature, step time, and each block number of PID, Time signal 1 to 8, Wait, Alarm Output to be used respectively in order from step number 0.
(Enter the block number to each step even if the same number is used.)
- Plot the step temperature on the Program pattern sheet.

● Explanation of Program pattern sheet

Vertical axis : Temperature (°C or °F)

Horizontal axis: Step time (Hours: Minutes or Minutes: Seconds)

- Setting value to the step temperature is the step end temperature.
- Setting value to the step time is the process time.

The relation of the Step temperature and Step time is as shown the example on the next page.

[Step 0]: It controls the temperature so as to be 500°C by 30 minutes (0:30)

If SV start is selected by Program control starting system (page 67), it controls from the SV, and if PV or PVR start is selected, it controls so as to be 500°C quickly changing the SV to PV.

[Step 1]: It controls the temperature at the fixed value 500°C for 1 hour (1:00).

⟨PID block⟩

Consists of Control output (OUT1) proportional band, Integral time, Derivative time and Control output (OUT2) proportional band (*), (10 types of block number 0 to 9 can be set)

⟨Time signal block⟩

Consists of Time signal output OFF time and Time signal output ON time setting value.

16 types of Time signal block (Block number 0 to 15) can be set to Time signal 1 to 8 (TS1 to TS8) respectively. With the Time signal 1 to 5 (TS1 to TS5), it can be set only when [Time signal output] is selected by [Time signal output/Status output section (page 70 to 72)].

⟨Wait block⟩

10 types of Wait block (Block number 0 to 9) can be set.

⟨Alarm block⟩

Consists of Alarm 1 action point, Alarm 2 action point (only when the option A2 is added), Alarm 3 action point and Alarm 4 action point.

⟨Output block⟩

Consists of Control output (OUT1) high limit, Control output (OUT1) low limit, Control output (OUT2) high limit (*), Control output (OUT2) low limit (*) and Control output (OUT1) changing rate limit.

10 types of Output block (Block number 0 to 9) can be set.

(*): Only when the option DR, DS or DA is applied.

● Program pattern graphing example

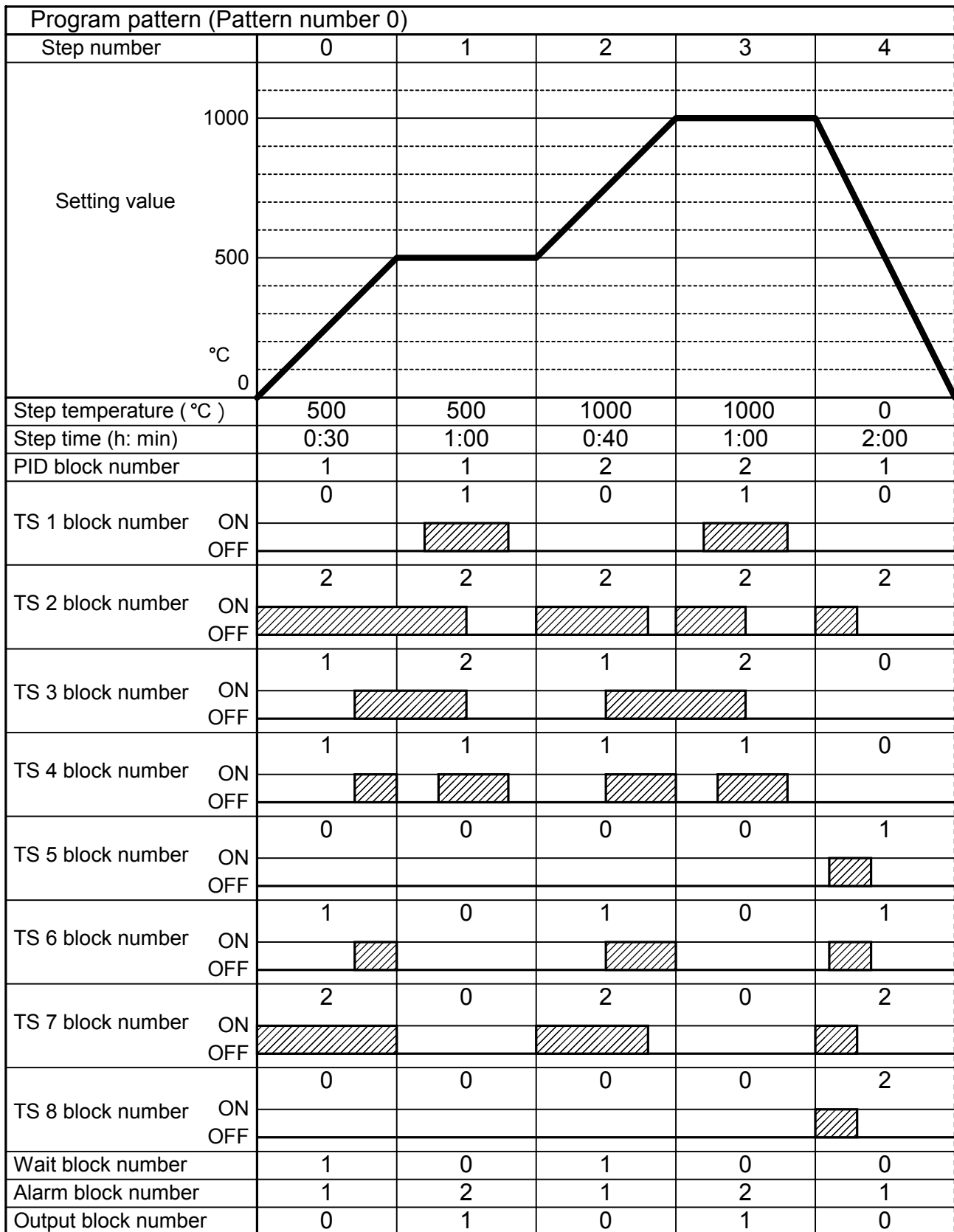

Even though the step intervals are shown to be equal length on the sheet, the actual length depends on the amount of time in a step.

● **Data Sheet making**

Copy the Data sheet (Page 129) and make the Data sheet by following procedure.

- Enter only necessary items of block data for PID, Time signal 1 to 8, Wait, Alarm and Output.
- Enter other setting items if necessary.

● **Data sheet making example**

[PID block]

No.	Control output (OUT1) Proportional band	Integral time	Derivative time	(ARW)	Control output (OUT2) Proportional band
0	2.5%	200sec.	50sec.	50%	2.5%
1	2.0%	180sec.	30sec.	40%	2.0%
2	1.8%	80sec.	20sec.	60%	1.8%

[Time signal block (option: TS)]

No.	Output OFF time (hours: minutes)	Output ON time (hours: minutes)
0	0: 00	0: 00
1	0: 20	0: 30
2	0: 00	0: 30

[Wait block]

No.	Wait value
0	0 (OFF)
1	10℃
2	5℃

[Alarm block]

No.	Alarm 1 (A1) action point (Pattern end output)	Alarm 2 (A2) action point (Process value alarm)	Alarm 3 (A3) action point (High limit alarm)	Alarm 4 (A4) action point Point (Low limit alarm)
0		1370℃	0 (OFF)	0 (OFF)
1		1370℃	10℃	10℃
2		1370℃	5℃	5℃

[Output block]

No.	Control output (OUT1) High limit	Control output (OUT1) Low limit	Control output (OUT2) High limit	Control output (OUT2) Low limit	Control output (OUT1) Changing rate limit
0	100%	0%	100%	0%	0%/sec
1	100%	10%	100%	10%	10%/sec
2	80%	0%	80%	0%	0%/sec

- Proportional cycle : 15 seconds
- Number of repeat : 1
- Pattern link : No link
- Communication Transfer rate : 9600bps
- Communication Instrument number: 1
- Overshoot suppression factor : 1.0

[Fixed value control parameter]

- Main setting value [G]]: 1000°C
- Control output (OUT1) proportional band [P]]: 2.0%
- Integral time [I]]: 180 seconds
- Derivative time [d]]: 30 seconds
- Anti-reset windup [n]]: 50%
- Control output (OUT2) proportional band [Pb]]: 2.0% (When multiplying factor 1.0)
- Temperature alarm (A1) setting value [A1]]: Pattern end output
- Temperature alarm (A2) setting value [A2]]: 1370°C (Process value alarm)
- Temperature alarm (A3) setting value [A3]]: 10°C (High limit alarm)
- Temperature alarm (A4) setting value [A4]]: 10°C (Low limit alarm)

● Data sheet and Program pattern sheet

[PID block]

No.	Control output (OUT1) Proportional band	Integral time	Derivative time	ARW	Control output (OUT2) Proportional band
0	%	sec	sec	%	%
1	%	sec	sec	%	%
2	%	sec	sec	%	%
3	%	sec	sec	%	%
4	%	sec	sec	%	%
5	%	sec	sec	%	%
6	%	sec	sec	%	%
7	%	sec	sec	%	%
8	%	sec	sec	%	%
9	%	sec	sec	%	%

[Time signal block (option: TS)]

No.	Output OFF time (:)	Output ON time (:)
0		
1		
2		
3		
4		
5		
6		
7		
8		
9		
10		
11		
12		
13		
14		
15		

[Wait block]

No.	Wait value
0	
1	
2	
3	
4	
5	
6	
7	
8	
9	

[Alarm block]

No.	Alarm 1 (A1) action point ()	Alarm 2 (A2) action point ()	Alarm 3 (A3) action point ()	Alarm 4 (A4) action point ()
0				
1				
2				
3				
4				
5				
6				
7				
8				
9				

[Output block]

No.	Control output (OUT1) High limit	Control output (OUT1) Low limit	Control output (OUT2) High limit	Control output (OUT2) Low limit	Control output (OUT1) Changing rate limit
0	%	%	%	%	%/sec
1	%	%	%	%	%/sec
2	%	%	%	%	%/sec
3	%	%	%	%	%/sec
4	%	%	%	%	%/sec
5	%	%	%	%	%/sec
6	%	%	%	%	%/sec
7	%	%	%	%	%/sec
8	%	%	%	%	%/sec
9	%	%	%	%	%/sec

- Proportional cycle : _____
- Number of repeat : _____
- Pattern link : _____
- Communication Transfer rate : _____
- Communication Instrument number: _____
- Overshoot suppression factor : _____

[Fixed value control parameter]

- Main setting value [k] : _____
- Control output (OUT1) proportional band [P] : _____ %
- Integral time [I] : _____ sec
- Derivative time [d] : _____ sec
- Anti-reset windup [n] : _____ %
- Control output (OUT2) proportional band [Pb] : _____ %
- Temperature alarm (A1) setting value [A1] : _____
- Temperature alarm (A2) setting value [A2] : _____
- Temperature alarm (A3) setting value [A3] : _____
- Temperature alarm (A4) setting value [A4] : _____

Program pattern (Pattern number)					
Step number	0	1	2	3	4
Setting value (SV)					
Step temperature (°C)					
Step time (:)					
PID block number					
TS 1 block number					
ON					
OFF					
TS 2 block number					
ON					
OFF					
TS 3 block number					
ON					
OFF					
TS 4 block number					
ON					
OFF					
TS 5 block number					
ON					
OFF					
TS 6 block number					
ON					
OFF					
TS 7 block number					
ON					
OFF					
TS 8 block number					
ON					
OFF					
Wait block number					
Alarm block number					
Output block number					

Program pattern (Pattern number)					Step number
5	6	7	8	9	
					Setting value (SV)
					Step temperature (°C)
					Step time (:)
					PID block number
					ON TS 1 block number OFF
					ON TS 2 block number OFF
					ON TS 3 block number OFF
					ON TS 4 block number OFF
					ON TS 5 block number OFF
					ON TS 6 block number OFF
					ON TS 7 block number OFF
					ON TS 8 block number OFF
					Wait block number
					Alarm block number
					Output block number

MEMO

MEMO

**** Inquiry ****

For any inquiry of this controller, after checking the following as to the controller, please contact your shop where purchased, or our agency.

- Model ----- PC-935-R/M
- Type of input ----- K
- Option ----- A2, TS
- Instrument number ----- No. x x x x x x

In addition to the above, let us know the details of malfunction, if any, and the operating conditions specifically on job site.

For inquiry about the specification change of this products, please contact us or out agency.