

This manual contains instructions for the communication functions, operations and notes when operating the DCL-33A.

To prevent accidents arising from the misuse of this controller, please ensure the operator receives this manual.

**Warning**

Turn the power supply to the instrument off before wiring or checking. Working on or touching the terminal with the power switched on may result in severe injury or death due to electrical shock.

# 1. System Configuration

## 1.1 When Using USB Communication Cable CMC-001-3 (Sold Separately)

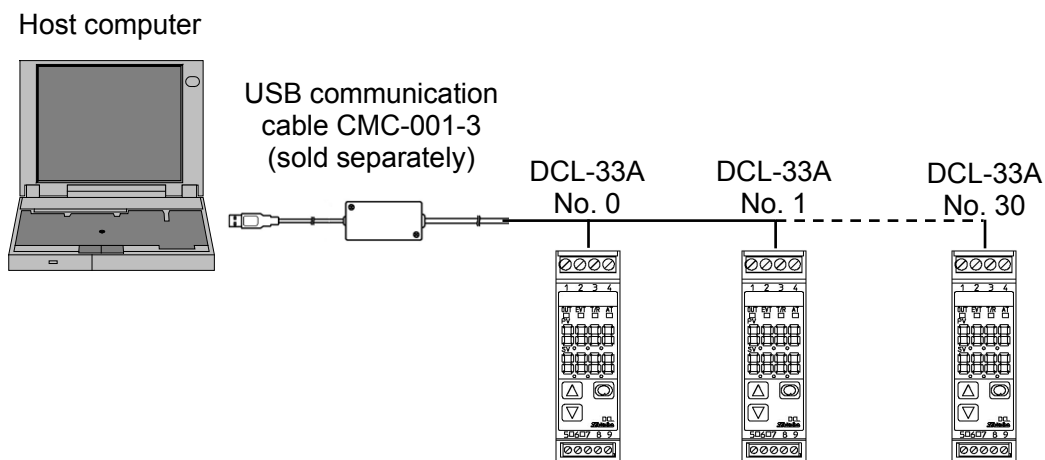

(Fig. 1.1-1)

## 1.2 When Using Communication Converter IF-400 (Sold Separately)

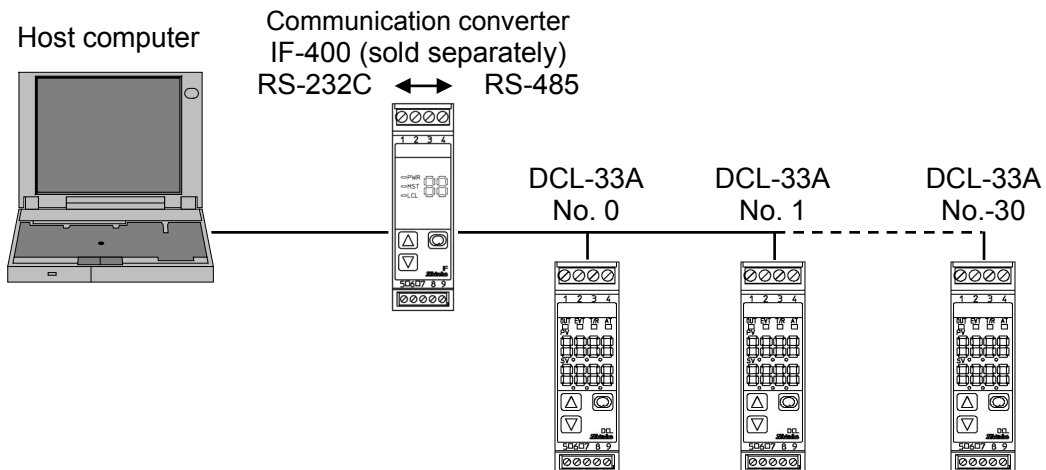

(Fig. 1.2-1)

## 2. Wiring

### 2.1 When Using USB Communication Cable CMC-001-3 (Sold Separately)

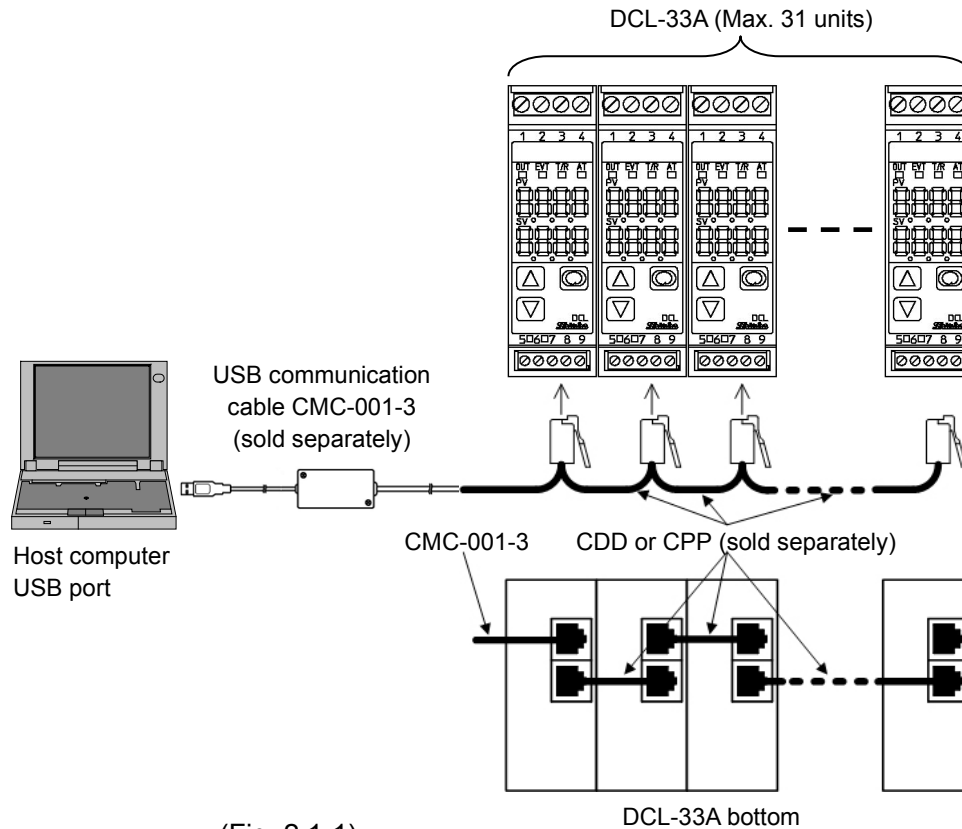

(Fig. 2.1-1)

### 2.2 When Using Communication Converter IF-400 (Sold Separately)

- D-sub 9-pin connector

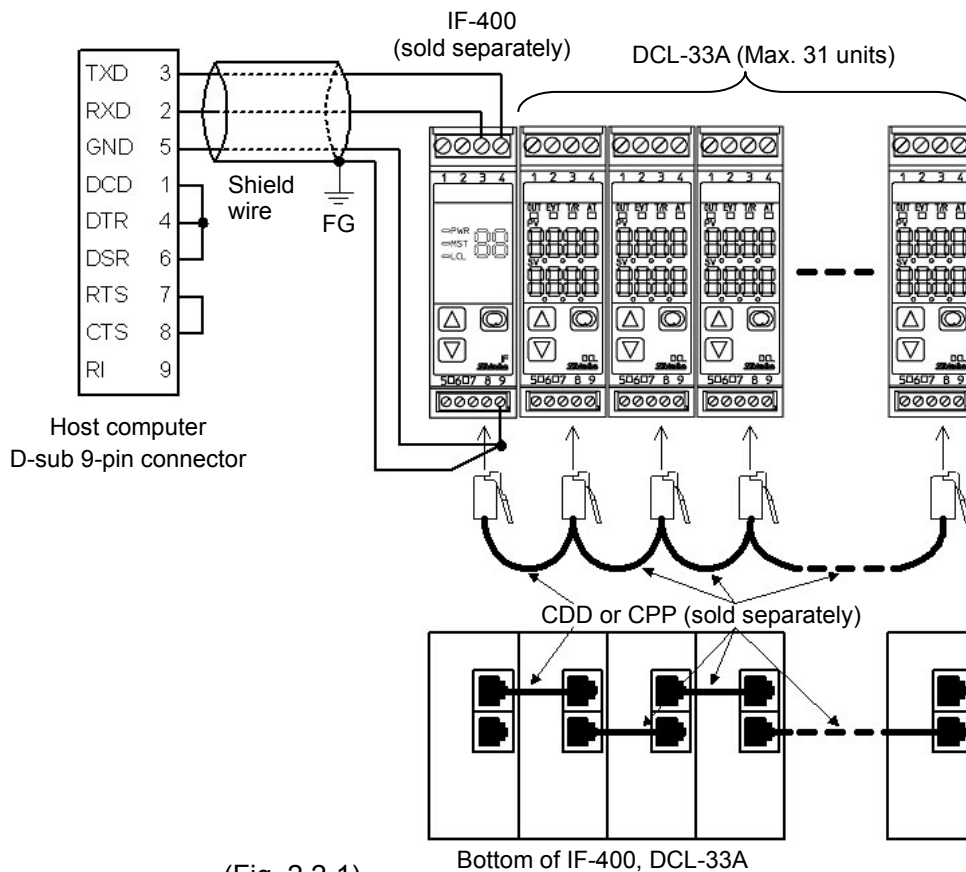

(Fig. 2.2-1)

### Shield wire

Be sure to ground only one end of the shield wire to avoid a ground loop. If both ends of the shield wire are grounded, the circuit will be closed, resulting in a ground loop. This may cause noise.

Recommended cable: OTSC-VB 2PX0.5SQ (made by Onamba Co., Ltd.) or equivalent



(Use a twisted pair cable.)

### Terminator (Terminal resistor)

The terminator is mounted at the end of the wire when connecting multiple peripheral devices to a personal computer. The terminator prevents signal reflection and disturbance.

Do not connect a terminator to the communication line because each DCL-33A has built-in pull-up and pull-down resistors.

## 3. Setting Communication Parameters

Press and hold the  and  keys (in that order) together for approx. 3 seconds in the PV/SV Display. The unit enters Auxiliary function setting mode 1.

Press the  key twice.

“Communication protocol” will appear.

Use the  or  key for settings or selections, and register them by pressing the  key.

Characters, Factory Default	Setting Item, Function, Setting Range (Selection item)
cñ4L noñL	<b>Communication protocol</b> <ul style="list-style-type: none"> <li>• Selects the communication protocol.</li> <li>• noñL: Shinko protocol</li> <li>• ñodP: MODBUS ASCII mode</li> <li>• ñodr: MODBUS RTU mode</li> <li>• bññL: Shinko protocol (Block Read/Write available)</li> <li>• bñdP: MODBUS ASCII mode (Block Read/Write available)</li> <li>• bñdr: MODBUS RTU mode (Block Read/Write available)</li> </ul>
cñno □□□□	<b>Instrument number</b> <ul style="list-style-type: none"> <li>• Sets the instrument number.</li> <li>The instrument numbers should be set one by one when multiple instruments are connected in Serial communication, otherwise communication is impossible.</li> <li>• Setting range: 0 to 95</li> </ul>
cñ4P □□96	<b>Communication speed</b> <ul style="list-style-type: none"> <li>• Selects a communication speed equal to that of the host computer.</li> <li>• □□24: 2400 bps</li> <li>• □□48: 4800 bps</li> <li>• □□96: 9600 bps</li> <li>• □ 192: 19200 bps</li> <li>• □384: 38400 bps</li> </ul>
cñPr EEEñ	<b>Parity</b> <ul style="list-style-type: none"> <li>• Selects the parity.</li> <li>• Not available if Shinko protocol or Shinko protocol (Block Read/Write available) is selected in [Communication protocol].</li> <li>• nonE: No parity</li> <li>• EEEñ: Even</li> <li>• odd□: Odd</li> </ul>
cñ4r □□□ 1	<b>Stop bit</b> <ul style="list-style-type: none"> <li>• Selects the stop bit.</li> <li>• Not available if Shinko protocol or Shinko protocol (Block Read/Write available) is selected in [Communication protocol].</li> <li>• □□□ 1: 1 bit</li> <li>• □□□ 2: 2 bits</li> </ul>

Press the  key. The unit reverts to the PV/SV Display Mode.

Settings are complete.

## 4. Communication Procedure

Communication starts with command transmission from the host computer (hereafter Master), and ends with the response of the DCL-33A (hereafter Slave).

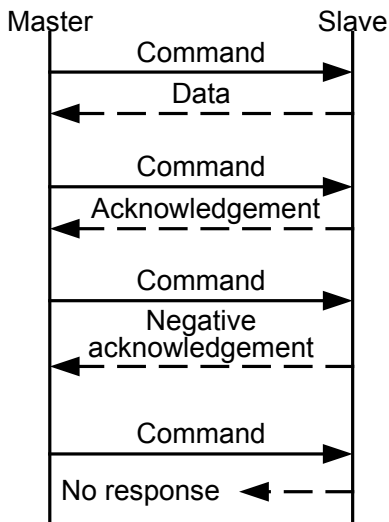

(Fig. 4-1)

### • Response with data

When the master sends the Read command, the slave responds with the corresponding set value or current status.

### • Acknowledgement

When the master sends the Write command, the slave responds by sending the acknowledgement after the processing is terminated.

### • Negative acknowledgement

When the master sends a non-existent command or value out of the setting range, the slave returns a negative acknowledgement.

### • No response

The slave will not respond to the master in the following cases:

- Global address (Shinko protocol) is set.
- Broadcast address (MODBUS protocol) is set.
- Communication error (framing error, parity error)
- Checksum error (Shinko protocol), LRC discrepancy (MODBUS ASCII mode), CRC-16 discrepancy (MODBUS RTU mode)

### Communication timing between the master and slave

#### Master Side (Take note while programming)

When the master starts transmission through the RS-485 communication line, the master is arranged so as to provide an idle status (mark status) transmission period of 1 or more characters before sending the command to ensure synchronization on the receiving side.

Set the program so that the master can disconnect the transmitter from the communication line within a 1 character transmission period after sending the command in preparation for reception of the response from the slave.

To avoid collision of transmissions between the master and the slave, send the next command after carefully checking that the master has received the response.

If a response to the command is not returned due to communication errors, set the Retry Processing to send the command again. (It is recommended to execute Retry twice or more.)

#### Slave Side

When the slave starts transmission through the RS-485 communication line, the slave is arranged so as to provide an idle status (mark status) transmission period of 1 or more characters before sending the response to ensure synchronization on the receiving side.

The slave is arranged so as to disconnect the transmitter from the communication line within a 1 character transmission period after sending the response.

# 5. Shinko Protocol

## 5.1 Transmission Mode

Shinko protocol is composed of ASCII.

Hexadecimal (0 to 9, A to F), which is divided into high order (4-bit) and low order (4-bit) out of 8-bit binary data in command is transmitted as ASCII characters.

Data format    Start bit: 1 bit  
                     Data bit: 7 bits  
                     Parity: Even  
                     Stop bit: 1 bit

Error detection: Checksum

## 5.2 Command Configuration

All commands are composed of ASCII.

The data (set value, decimal number) is represented by a hexadecimal number.

The negative numbers are represented in 2's complement.

Numerals written below the command represent the number of characters.

### (1) Write command

#### • Write a single piece of data

Header (02H)	Address	Sub address (20H)	Command type (50H)	Data item	Data	Checksum	Delimiter (03H)
1	1	1	1	4	4	2	1

#### • Write multiple pieces of data

Header (02H)	Address	Sub address (20H)	Command type (54H)	Data item	
1	1	1	1	4	

	Data	Checksum	Delimiter (03H)
	4 x n	2	1

n: Amount of data

### (2) Read command

#### • Read a single piece of data

Header (02H)	Address	Sub address (20H)	Command type (20H)	Data item	Checksum	Delimiter (03H)
1	1	1	1	4	2	1

#### • Read multiple pieces of data

Header (02H)	Address	Sub address (20H)	Command type (24H)	Data item	Amount of read data n	Checksum	Delimiter (03H)
1	1	1	1	4	4	2	1

### (3) Response with data

#### • Response to 'Read a single piece of data'

Header (06H)	Address	Sub address (20H)	Command type (20H)	Data item	Data	Checksum	Delimiter (03H)
1	1	1	1	4	4	2	1

• **Response to 'Read multiple pieces of data'**

Header (06H)	Address	Sub address (20H)	Command type (24H)	Data item
1	1	1	1	4

Data	Checksum	Delimiter (03H)
4 x n	2	1

n: Amount of data

**(4) Acknowledgement**

Header (06H)	Address	Checksum	Delimiter (03H)
1	1	2	1

**(5) Negative acknowledgement**

Header (15H)	Address	Error code	Checksum	Delimiter (03H)
1	1	1	2	1

**Header:** Control code to represent the beginning of the command or the response.  
ASCII is used.

Write command, Read command: STX (02H) fixed

Response with data, Acknowledgement: ACK (06H) fixed

Negative acknowledgement: NAK (15H) fixed

**Instrument number (Address):** Numbers by which the master discerns each slave.

Instrument number 0 to 94 and Global address 95.

ASCII (20H to 7FH) is used by adding 20H to instrument numbers 0 to 95 (00H to 5FH).

95 (7FH) is called Global address, which is used when the same command is sent to all the slaves connected. However, the response is not returned.

**Sub address:** 20H fixed

**Command type:** Codes for Write command and Read command.

Command Type	Contents	Description
20H	Read (A single piece of data)	Reads a single piece of data.
24H	Read (Multiple pieces of data)	Reads consecutive multiple pieces of data. (Amount of data: Max. 100)
50H	Write (A single piece of data)	Writes a single piece of data.
54H	Write (Multiple pieces of data)	Writes consecutive multiple pieces of data. (Amount of data: Max. 100)

**Notes about Read/Write multiple pieces of data**

When reading or writing multiple pieces of data, as it takes time until slave sends response data, the master determines no response based on the timeout period below after sending a command.

Timeout period calculation: 6 ms x Amount of data

**Data item:** Classification of the command object.

Composed of 4-digit hexadecimal numbers, using ASCII.

Refer to Section '7. Communication Command Table' (pp.23 to 38).

**Data:** The contents of data (values) differ depending on the Write command.

Composed of 4-digit hexadecimal numbers, using ASCII.

Refer to Section '7. Communication Command Table' (pp.23 to 38).

**Checksum:** 2-character data to detect communication errors.

**Delimiter:** Control code to represent the end of command.  
 ASCII code ETX (03H) fixed

**Error code:** Represents an error type using ASCII.

Error Code	Contents
1 (31H)	Non-existent command
2 (32H)	Not used
3 (33H)	Setting outside the setting range
4 (34H)	Status unable to be written (e.g. AT is performing.)
5 (35H)	During setting mode by keypad operation

### 5.3 Checksum Calculation

Checksum is used to detect receiving errors in the command or data.

Set the program for the master side as well to calculate the checksum of the response data from the slaves so that communication errors can be checked.

The ASCII code (hexadecimal) corresponding to the characters which range from the address to that before the checksum is converted to binary notation, and the total value is calculated.

The lower one byte of the total value is converted to 2's complement, and then to hexadecimal numbers, that is, ASCII code for the checksum.

- 1's complement: Reverse each binary bit. 0 will become 1 and vice versa.
- 2's complement: Add 1 to 1's complement.

#### [Example of checksum calculation]

Write SV1 (0001H) to 600°C (0258H). See (Fig. 5.3-1).

Address (instrument number): 0 (20H)

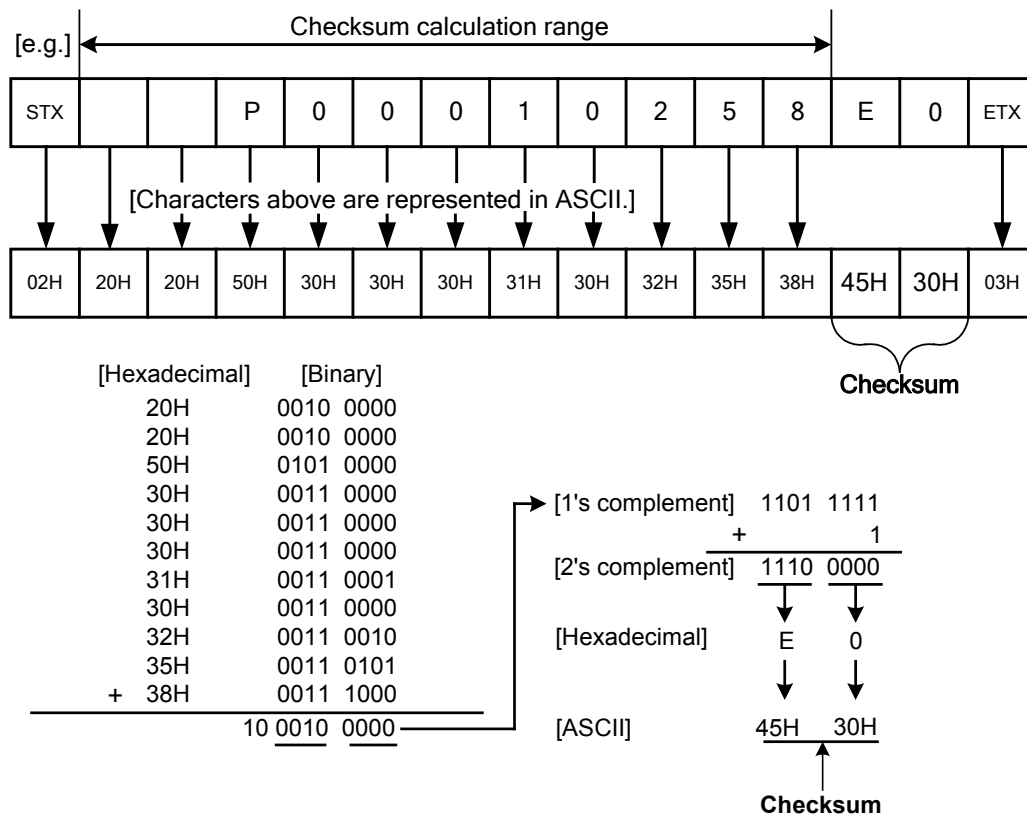

(Fig. 5.3-1)

## 5.4 Command Example

Numerals written below the command represent the number of characters.

### (1) Read [Address 1, PV]

- Read command from the master

Header (02H)	Address (21H)	Sub address (20H)	Command type (20H)	Data item [0080H] (30H 30H 38H 30H)	Checksum (44H 37H)	Delimiter (03H)
1	1	1	1	4	2	1

- A response from the slave in normal status [When PV is 25°C (0019H)]

Header (06H)	Address (21H)	Sub address (20H)	Command type (20H)	Data item [0080H] (30H 30H 38H 30H)	Data [0019H] (30H 30H 31H 39H)	Checksum (30H 44H)	Delimiter (03H)
1	1	1	1	4	4	2	1

### (2) Read [Address 1, SV1]

- Read command from the master

Header (02H)	Address (21H)	Sub address (20H)	Command type (20H)	Data item [0001H] (30H 30H 30H 31H)	Checksum (44H 45H)	Delimiter (03H)
1	1	1	1	4	2	1

- A response from the slave in normal status [When SV1 is 600°C (0258H)]

Header (06H)	Address (21H)	Sub address (20H)	Command type (20H)	Data item [0001H] (30H 30H 30H 31H)	Data [0258H] (30H 32H 35H 38H)	Checksum (30H 46H)	Delimiter (03H)
1	1	1	1	4	4	2	1

### (3) Write [Address 1, SV1 600°C (0258H)]

- Write command from the master

Header (02H)	Address (21H)	Sub address (20H)	Command type (50H)	Data item [0001H] (30H 30H 30H 31H)	Data [0258H] (30H 32H 35H 38H)	Checksum (44H 46H)	Delimiter (03H)
1	1	1	1	4	4	2	1

- A response from the slave in normal status

Header (06H)	Address (21H)	Checksum (44H 46H)	Delimiter (03H)
1	1	2	1



**(4) Read [Address 1, 25 commands from SV1]**

- Read command from the master

Header (02H)	Address (21H)	Sub address (20H)	Command type (24H)	Data item [0001H] (30H 30H 30H 31H)	Amount of read data 25 [0019H] (30H 30H 31H 39H)	Checksum (31H 30H)	Delimiter (03H)
1	1	1	1	4	4	2	1

- A response from the slave in normal status

Header (06H)	Address (21H)	Sub address (20H)	Command type (24H)	Data item [0001H] (30H 30H 30H 31H)
1	1	1	1	4

	Data [00000000055A...0000] (30H 30H 30H 30H 30H 30H 30H 30H 30H 35H 35H 41H...30H 30H 30H 30H)	Checksum (43H 38H)	Delimiter (03H)
	100 (4 x 25)	2	1

Response data becomes as follows.

	Data Item	Data	Data (Converted to Hexadecimal)
0001H	SV1	0	0000H
0002H	Input type	K [-200 to 1370°C]	0000H
0003H	Scaling high limit	1370	055AH
0004H	Scaling low limit	-200	FF38H
0005H	Decimal point place	No decimal point	0000H
0006H	Alarm 1 type	No alarm action	0000H
0007H	Alarm 2 type	No alarm action	0000H
0008H	Alarm 3 type	No alarm action	0000H
0009H	Alarm 4 type	No alarm action	0000H
000AH	Reserved	0	0000H
000BH	Reserved	0	0000H
000CH	Reserved	0	0000H
000DH	Reserved	0	0000H
000EH	SV1	0	0000H
000FH	SV2	0	0000H
0010H	Reserved	0	0000H
0011H	Reserved	0	0000H
0012H	Alarm 1 value	0	0000H
0013H	Alarm 1 high limit alarm value	0	0000H
0014H	Alarm 2 value	0	0000H
0015H	Alarm 2 high limit alarm value	0	0000H
0016H	Alarm 3 value	0	0000H
0017H	Alarm 3 high limit alarm value	0	0000H
0018H	Alarm 4 value	0	0000H
0019H	Alarm 4 high limit alarm value	0	0000H

**(5) Write [Address 1, 25 commands from SV1]**

(e.g.) The data (25 commands from SV1) is shown below.

	Data Item	Data	Data (Converted to Hexadecimal)
0001H	SV1	2000	07D0H
0002H	Input type	K [-199.9 to 400.0°C]	0001H
0003H	Scaling high limit	4000	0FA0H
0004H	Scaling low limit	0	0000H
0005H	Decimal point place	XXX.X (1 digit after decimal point)	0001H
0006H	Alarm 1 type	High/Low limits independent alarm	000AH
0007H	Alarm 2 type	High limit alarm	0001H
0008H	Alarm 3 type	Low limit alarm	0002H
0009H	Alarm 4 type	No alarm action	0000H
000AH	Reserved	0	0000H
000BH	Reserved	0	0000H
000CH	Reserved	0	0000H
000DH	Reserved	0	0000H
000EH	SV1	2000	07D0H
000FH	SV2	0	0000H
0010H	Reserved	0	0000H
0011H	Reserved	0	0000H
0012H	Alarm 1 value	1000	03E8H
0013H	Alarm 1 high limit alarm value	500	01F4H
0014H	Alarm 2 value	1000	03E8H
0015H	Alarm 2 high limit alarm value	0	0000H
0016H	Alarm 3 value	-1500	FA24H
0017H	Alarm 3 high limit alarm value	0	0000H
0018H	Alarm 4 value	0	0000H
0019H	Alarm 4 high limit alarm value	0	0000H

- Write command from the master (When writing the above data)

Header (02H)	Address (21H)	Sub address (20H)	Command type (54H)	Data item [0001H] (30H 30H 30H 31H)
1	1	1	1	4

Data [07D000010FA0...0000] (30H 37H 44H 30H 30H 30H 30H 31H 30H 46H 41H 30H...30H 30H 30H 30H)			Checksum (45H 46H)	Delimiter (03H)
100 (4 x 25)			2	1

- Response from the slave in normal status

Header (06H)	Address (21H)	Checksum (44H 46H)	Delimiter (03H)
1	1	2	1

# 6. MODBUS Protocol

## 6.1 Transmission Mode

There are 2 transmission modes (ASCII and RTU) in MODBUS protocol.

### 6.1.1 ASCII Mode

Hexadecimal (0 to 9, A to F), which is divided into high order (4-bit) and low order (4-bit) out of 8-bit binary data in command is transmitted as ASCII characters.

Data format Start bit: 1 bit  
 Data bit: 7 bits  
 Parity: Even (No parity, Odd) (Selectable)  
 Stop bit: 1 bit (2 bits) (Selectable)

Error detection : LRC (Longitudinal Redundancy Check)

### 6.1.2 RTU Mode

8-bit binary data in command is transmitted as it is.

Data format Start bit: 1 bit  
 Data bit: 8 bits  
 Parity: No parity (Even, Odd) (Selectable)  
 Stop bit: 1 bit (2 bits) (Selectable)

Error detection: CRC-16 (Cyclic Redundancy Check)

## 6.2 Data Communication Interval

### 6.2.1 ASCII Mode

No communication interval limit between characters

### 6.2.2 RTU Mode

1.5 character transmission times or less  
 (Communication speed 2400, 4800, 9600, 19200 bps: 1.5 character transmission times,  
 Communication speed 38400 bps: 750  $\mu$ s)

To transmit continuously, an interval between characters which consist of one message, must be within 1.5 character transmission times.

If an interval lasts longer than 1.5 character transmission times, the DCL-33A assumes that transmission from the master is finished, which results in a communication error, and will not return a response.

## 6.3 Message Configuration

### 6.3.1 ASCII Mode

ASCII mode message is configured to start by Header [: (colon) (3AH)] and end by Delimiter [CR (carriage return) (0DH) + LF (Line feed) (0AH)].

Data section: Max. 2 x 252 characters

Header (:)	Slave address	Function code	Data	Error check LRC	Delimiter (CR)	Delimiter (LF)
------------	---------------	---------------	------	-----------------	----------------	----------------

### 6.3.2 RTU Mode

RTU mode is configured to start after idle time is processed for more than 3.5 character transmissions, and end after idle time is processed for more than 3.5 character transmissions.

(Communication speed 2400, 4800, 9600, 19200 bps: 3.5 character transmission times,  
 Communication speed 38400 bps: 1.75 ms)

Data section: Max. 252 bytes

3.5 idle characters	Slave address	Function code	Data	Error check CRC-16	3.5 idle characters
---------------------	---------------	---------------	------	--------------------	---------------------

### (1) Slave Address

Slave address is an individual instrument number on the slave side, and is set within the range 0 to 95 (00H to 5FH). The master identifies slaves by the slave address of the requested message. The slave informs the master which slave is responding to the master by placing its own address in the response message.

Slave address 00H (Broadcast address) can identify all the slaves connected. However, slaves do not respond.

### (2) Function Code

The function code is the command code for the slave to undertake one of the following actions.

(Table 6.3-1)

Type	Function Code	Sub-Function Code	Contents
Data access	03 (03H)		Reads a single or multiple piece(s) of data from slave(s).
	04 (04H)		Reads information from slave(s).
	06 (06H)		Writes a single piece of data to slave(s).
	16 (10H)		Writes multiple pieces of data to slave(s).
Diagnostics	08 (08H)	00	Echoes back the request message.
	43 (2BH)	14	Reads device identification information.

The function code is used to discern whether the response is normal (acknowledgement) or if any error (negative acknowledgement) has occurred when the slave returns the response message to the master.

When acknowledgement is returned, the slave simply returns the original function code.

When negative acknowledgement is returned, the MSB of the original function code is set as 1 for the response.

For example, if the master sends request message setting 13H to the function code by mistake, slave returns 93H by setting the MSB to 1, because the former is an illegal function.

For negative acknowledgement, the exception codes below (Table 6.3-2) are set to the data of the response message, and returned to the master in order to inform it of what kind of error has occurred.

(Table 6.3-2)

Exception Code	Contents
1 (01H)	Illegal function (Non-existent function)
2 (02H)	Illegal data address (Non-existent data address)
3 (03H)	Illegal data value (Value out of the setting range)
17 (11H)	Shinko protocol error code 4 (Status unable to be written. (e.g.) AT is performing.)
18 (12H)	Shinko protocol error code 5 (During setting mode by keypad operation)

### (3) Data

Data differs depending on the function code.

A request message from the master is composed of a data item, amount of data and setting data.

A response message from the slave is composed of the byte count, data and exception codes in negative acknowledgements, corresponding to the request message.

The effective range of data is -32768 to 32767 (8000H to 7FFFH).

Refer to Section "7. Communication Command Table" (pp.23 to 38).

### (4) Error Check

#### ASCII Mode

After calculating LRC (Longitudinal Redundancy Check) from the slave address to the end of data, the calculated 8-bit data is converted to two ASCII characters, and are appended to the end of message.

#### How to Calculate LRC

- ① Create a message in RTU mode.
- ② Add all the values from the slave address to the end of data. This is assumed as X.
- ③ Make a complement for X (bit reverse). This is assumed as X.
- ④ Add a value of 1 to X. This is assumed as X.
- ⑤ Set X as an LRC to the end of the message.
- ⑥ Convert the whole message to ASCII characters.

## RTU Mode

After calculating CRC-16 (Cyclic Redundancy Check) from the slave address to the end of the data, the calculated 16-bit data is appended to the end of message in sequence from low order to high order.

### How to calculate CRC-16

In the CRC-16 system, the information is divided by the polynomial series. The remainder is added to the end of the information and transmitted. The generation of a polynomial series is as follows.

(Generation of polynomial series:  $X^{16} + X^{15} + X^2 + 1$ )

- ① Initialize the CRC-16 data (assumed as X) (FFFFH).
- ② Calculate exclusive OR (XOR) with the 1st data and X. This is assumed as X.
- ③ Shift X one bit to the right. This is assumed as X.
- ④ When a carry is generated as a result of the shift, XOR is calculated by X of ③ and the fixed value (A001H). This is assumed as X. If a carry is not generated, go to step ⑤.
- ⑤ Repeat steps ③ and ④ until shifting 8 times.
- ⑥ XOR is calculated with the next data and X. This is assumed as X.
- ⑦ Repeat steps ③ to ⑤.
- ⑧ Repeat steps ③ to ⑤ up to the final data.
- ⑨ Set X as CRC-16 to the end of message in sequence from low order to high order.

## 6.4 Message Example

### 6.4.1 ASCII Mode

Numerals written below the message represent the number of characters.

#### (1) Read [Slave address 1, PV (0100H)]

- A request message from the master

Header (3AH)	Slave address (30H 31H)	Function code (30H 33H)	Data item [0100H] (30H 31H 30H 30H)	Amount of data [0001H] (30H 30H 30H 31H)	Error check LRC (46H 41H)	Delimiter CR+LF (0DH 0AH)
1	2	2	4	4	2	2

- Response message from the slave in normal status [When PV is 600°C (0258H)]

Header (3AH)	Slave address (30H 31H)	Function code (30H 33H)	Response byte count [02H] (30H 32H)	Data [0258H] (30H 32H 35H 38H)	Error check LRC (41H 30H)	Delimiter CR+LF (0DH 0AH)
1	2	2	2	4	2	2

#### (2) Write [Slave address 1, SV1 (0001H)]

- A request message from the master [When writing SV1 to 600°C (0258H)]

Header (3AH)	Slave address (30H 31H)	Function code (30H 36H)	Data item [0001H] (30H 30H 30H 31H)	Data [0258H] (30H 32H 35H 38H)	Error check LRC (39H 45H)	Delimiter CR+LF (0DH 0AH)
1	2	2	4	4	2	2

- Response message from the slave in normal status

Header (3AH)	Slave address (30H 31H)	Function code (30H 36H)	Data item [0001H] (30H 30H 30H 31H)	Data [0258H] (30H 32H 35H 38H)	Error check LRC (39H 45H)	Delimiter CR+LF (0DH 0AH)
1	2	2	4	4	2	2

- Response message from the slave in exception (error) status (When a value out of the setting range is written)

The function code MSB is set to 1 for the response message in exception (error) status [86H (38H 36H)].

The exception code 03H (30H 33H: Value out of the setting range) is returned (error).

Header (3AH)	Slave address (30H 31H)	Function code (38H 36H)	Exception code [03H] (30H 33H)	Error check LRC (37H 36H)	Delimiter CR+LF (0DH 0AH)
1	2	2	2	2	2

### (3) Read [Slave address 1, SV1 (0001H)]

- A request message from the master

Header (3AH)	Slave address (30H 31H)	Function code (30H 33H)	Data item [0001H] (30H 30H 30H 31H)	Amount of data [0001H] (30H 30H 30H 31H)	Error check LRC (46H 41H)	Delimiter CR+LF (0DH 0AH)
1	2	2	4	4	2	2

- Response message from the slave in normal status [When SV1 is 600°C (0258H)]

Header (3AH)	Slave address (30H 31H)	Function code (30H 33H)	Response byte count [02H] (30H 32H)	Data [0258H] (30H 32H 35H 38H)	Error check LRC (41H 30H)	Delimiter CR+LF (0DH 0AH)
1	2	2	2	4	2	2

- Response message from the slave in exception (error) status (When data item is incorrect)  
The function code MSB is set to 1 for the response message in exception (error) status [83H (38H 33H)].

The exception code 02H (30H 32H: Non-existent data address) is returned (error).

Header (3AH)	Slave address (30H 31H)	Function code (38H 33H)	Exception code [02H] (30H 32H)	Error check LRC (37H 41H)	Delimiter CR+LF (0DH 0AH)
1	2	2	2	2	2

### (4) Read [Slave address 1, 25 commands from SV1]

- A request message from the master

Header (3AH)	Slave address (30H 31H)	Function code (30H 33H)	Data item [0001H] (30H 30H 30H 31H)	Amount of data [0019H] (30H 30H 31H 39H)	Error check LRC (45H 32H)	Delimiter CR+LF (0DH 0AH)
1	2	2	4	4	2	2

- Response message from the slave in normal status

Header (3AH)	Slave address (30H 31H)	Function code (30H 33H)	Response byte count [32H] (33H 32H)
1	2	2	2

Data [00000000055A...0000] (30H 30H 30H 30H 30H 30H 30H 30H 30H 30H 35H 35H 41H...30H 30H 30H 30H)	Error check LRC (33H 34H)	Delimiter CR+LF (0DH 0AH)
100 (4 x 25)	2	2

Response data section is shown below.

	Data Item	Data	Data (Converted to Hexadecimal)
0001H	SV1	0	0000H
0002H	Input type	K [-200 to 1370°C]	0000H
0003H	Scaling high limit	1370	055AH
0004H	Scaling low limit	-200	FF38H
0005H	Decimal point place	No decimal point	0000H
0006H	Alarm 1 type	No alarm action	0000H
0007H	Alarm 2 type	No alarm action	0000H
0008H	Alarm 3 type	No alarm action	0000H
0009H	Alarm 4 type	No alarm action	0000H
000AH	Reserved	0	0000H
000BH	Reserved	0	0000H
000CH	Reserved	0	0000H
000DH	Reserved	0	0000H
000EH	SV1	0	0000H
000FH	SV2	0	0000H

0010H	Reserved	0	0000H
0011H	Reserved	0	0000H
0012H	Alarm 1 value	0	0000H
0013H	Alarm 1 high limit alarm value	0	0000H
0014H	Alarm 2 value	0	0000H
0015H	Alarm 2 high limit alarm value	0	0000H
0016H	Alarm 3 value	0	0000H
0017H	Alarm 3 high limit alarm value	0	0000H
0018H	Alarm 4 value	0	0000H
0019H	Alarm 4 high limit alarm value	0	0000H

**(5) Write (Slave address 1, 25 commands from SV1)**

(e.g.) The data (25 commands from SV1) is shown below.

	Data Item	Data	Data (Converted to Hexadecimal)
0001H	SV1	2000	07D0H
0002H	Input type	K [-199.9 to 400.0°C]	0001H
0003H	Scaling high limit	4000	0FA0H
0004H	Scaling low limit	0	0000H
0005H	Decimal point place	XXX.X (1 digit after decimal point)	0001H
0006H	Alarm 1 type	High/Low limits independent alarm	000AH
0007H	Alarm 2 type	High limit alarm	0001H
0008H	Alarm 3 type	Low limit alarm	0002H
0009H	Alarm 4 type	No alarm action	0000H
000AH	Reserved	0	0000H
000BH	Reserved	0	0000H
000CH	Reserved	0	0000H
000DH	Reserved	0	0000H
000EH	SV1	2000	07D0H
000FH	SV2	0	0000H
0010H	Reserved	0	0000H
0011H	Reserved	0	0000H
0012H	Alarm 1 value	1000	03E8H
0013H	Alarm 1 high limit alarm value	500	01F4H
0014H	Alarm 2 value	1000	03E8H
0015H	Alarm 2 high limit alarm value	0	0000H
0016H	Alarm 3 value	-1500	FA24H
0017H	Alarm 3 high limit alarm value	0	0000H
0018H	Alarm 4 value	0	0000H
0019H	Alarm 4 high limit alarm value	0	0000H

- A request message from the master (when writing the above data)

Header (3AH)	Slave address (30H 31H)	Function code (31H 30H)	Data item [0001H] (30H 30H 30H 31H)	Amount of data [0019H] (30H 30H 31H 39H)	Byte count [32H] (33H 32H)
1	2	2	4	4	2

Data [07D00001 ••• 0000 (30H 37H 44H 30H 30H 30H 30H 31H ••• 30H 30H 30H 30H)]	Error check LRC (34H 45H)	Delimiter CR+LF (0DH 0AH)
100 (4 x 25)	2	2

- Response message from the slave in normal status

Header (3AH)	Slave address (30H 31H)	Function code (31H 30H)	Data item [0001H] (30H 30H 30H 31H)	Amount of data [0019H] (30H 30H 31H 39H)	Error check LRC (44H 35H)	Delimiter CR+LF (0DH 0AH)
1	2	2	4	4	2	2

## 6.4.2 RTU Mode

Numerals written below the **message** represent the number of characters.

### (1) Read [Slave address 1, PV (0100H)]

- A request message from the master

3.5 idle characters	Slave address (01H)	Function code (03H)	Data item (0100H)	Amount of data (0001H)	Error check CRC-16 (85F6H)	3.5 idle characters
	1	1	2	2	2	

- Response message from the slave in normal status [When PV is 600°C (0258H)]

3.5 idle characters	Slave address (01H)	Function code (03H)	Response byte count (02H)	Data (0258H)	Error check CRC-16 (B8DEH)	3.5 idle characters
	1	1	1	2	2	

### (2) Write [Slave address 1, SV1 (0001H)]

- A request message from the master [When SV1 is written to 600°C (0258H)]

3.5 idle characters	Slave address (01H)	Function code (06H)	Data item (0001H)	Data (0258H)	Error check CRC-16 (D890H)	3.5 idle characters
	1	1	2	2	2	

- Response message from the slave in normal status

3.5 idle characters	Slave address (01H)	Function code (06H)	Data item (0001H)	Data (0258H)	Error check CRC-16 (D890H)	3.5 idle characters
	1	1	2	2	2	

- Response message from the slave in exception (error) status (When a value out of the setting range is set)  
The function code MSB is set to 1 for the response message in exception (error) status, and 86H is returned.

The Exception code 03H (Value out of the setting range) is returned (error).

3.5 idle characters	Slave address (01H)	Function code (86H)	Exception code (03H)	Error check CRC-16 (0261H)	3.5 idle characters
	1	1	1	2	

### (3) Read [Slave address 1, SV1 (0001H)]

- A request message from the master

3.5 idle characters	Slave address (01H)	Function code (03H)	Data item (0001H)	Data (0001H)	Error check CRC-16 (D5CAH)	3.5 idle characters
	1	1	2	2	2	

- Response message from the slave in normal status [When SV1 is 600°C (0258H)]

3.5 idle characters	Slave address (01H)	Function code (03H)	Response byte count (02H)	Data (0258H)	Error check CRC-16 (B8DEH)	3.5 idle characters
	1	1	1	2	2	

- Response message from the slave in exception (error) status (When data item is incorrect)  
The function code MSB is set to 1 for the response message in exception (error) status, and 83H is returned. The Exception code 02H (Non-existent data address) is returned (error).

3.5 idle characters	Slave address (01H)	Function code (83H)	Exception code (02H)	Error check CRC-16 (C0F1H)	3.5 idle characters
	1	1	1	2	



**(4) Read [Slave address 1, 25 commands from SV1]**

- A request message from the master

3.5 idle characters	Slave address (01H)	Function code (03H)	Data item (0001H)	Amount of data (0019H)	Error check CRC-16 (D5C0H)	3.5 idle characters
	1	1	2	2	2	

- Response message from the slave in normal status

3.5 idle characters	Slave address (01H)	Function code (03H)	Response byte count (32H)	Data (00000000055A...0000H)	Error check CRC-16 (60D9H)	3.5 idle characters
	1	1	1	50 (2 x 25)	2	

Response data section is shown below.

	Data Item	Data	Data (Converted to Hexadecimal)
0001H	SV1	0	0000H
0002H	Input type	K [-200 to 1370°C]	0000H
0003H	Scaling high limit	1370	055AH
0004H	Scaling low limit	-200	FF38H
0005H	Decimal point place	No decimal point	0000H
0006H	Alarm 1 type	No alarm action	0000H
0007H	Alarm 2 type	No alarm action	0000H
0008H	Alarm 3 type	No alarm action	0000H
0009H	Alarm 4 type	No alarm action	0000H
000AH	Reserved	0	0000H
000BH	Reserved	0	0000H
000CH	Reserved	0	0000H
000DH	Reserved	0	0000H
000EH	SV1	0	0000H
000FH	SV2	0	0000H
0010H	Reserved	0	0000H
0011H	Reserved	0	0000H
0012H	Alarm 1 value	0	0000H
0013H	Alarm 1 high limit alarm value	0	0000H
0014H	Alarm 2 value	0	0000H
0015H	Alarm 2 high limit alarm value	0	0000H
0016H	Alarm 3 value	0	0000H
0017H	Alarm 3 high limit alarm value	0	0000H
0018H	Alarm 4 value	0	0000H
0019H	Alarm 4 high limit alarm value	0	0000H

**(5) Write [Slave address 1, 25 commands from SV1]**

(e.g.) The data (25 commands from SV1) is shown below.

	Data Item	Data	Data (Converted to Hexadecimal)
0001H	SV1	2000	07D0H
0002H	Input type	K [-199.9 to 400.0°C]	0001H
0003H	Scaling high limit	4000	0FA0H
0004H	Scaling low limit	0	0000H
0005H	Decimal point place	XXX.X (1 digit after decimal point)	0001H
0006H	Alarm 1 type	High/Low limits independent alarm	000AH
0007H	Alarm 2 type	High limit alarm	0001H
0008H	Alarm 3 type	Low limit alarm	0002H
0009H	Alarm 4 type	No alarm action	0000H
000AH	Reserved	0	0000H
000BH	Reserved	0	0000H
000CH	Reserved	0	0000H
000DH	Reserved	0	0000H
000EH	SV1	2000	07D0H
000FH	SV2	0	0000H
0010H	Reserved	0	0000H
0011H	Reserved	0	0000H
0012H	Alarm 1 value	1000	03E8H
0013H	Alarm 1 high limit alarm value	500	01F4H
0014H	Alarm 2 value	1000	03E8H
0015H	Alarm 2 high limit alarm value	0	0000H
0016H	Alarm 3 value	-1500	FA24H
0017H	Alarm 3 high limit alarm value	0	0000H
0018H	Alarm 4 value	0	0000H
0019H	Alarm 4 high limit alarm value	0	0000H

- A request message from the master (When writing the above data)

3.5 idle characters	Slave address (01H)	Function code (10H)	Data item (0001H)	Amount of data (0019H)	Byte count (32H)
	1	1	2	2	1

Data (07D000010FA0 ••• 0000H)	Error check CRC-16 (5C89H)	3.5 idle characters
50 (2 x 25)	2	

- Response message from the slave in normal status

3.5 idle characters	Slave address (01H)	Function code (10H)	Data item (0001H)	Amount of data (0019H)	Error check CRC-16 (5003H)	3.5 idle characters
	1	1	2	2	2	

## 6.5 Diagnostics Function

MODBUS protocol has the following diagnostics functions.

- Echoes back the request message.
- Reads device identification information.

### 6.5.1 Message Configuration

#### ASCII mode

Header (:)	Slave address	Function code	Data	Error check LRC	Delimiter (CR)	Delimiter (LF)
---------------	------------------	------------------	------	--------------------	-------------------	-------------------

#### RTU mode

3.5 idle characters	Slave address	Function code	Data	Error check CRC-16	3.5 idle characters
------------------------	------------------	------------------	------	-----------------------	------------------------

#### (1) Slave address

Slave address is an individual instrument number on the slave side, and is set within the range 1 to 95 (01H to 5FH).

The master identifies slaves by the slave address of the requested message.

The slave informs the master which slave is responding to the master by placing its own address in the response message.

Diagnostics function is disabled for the Slave address 0 (00H, broadcast address).

#### (2) Function code

The function code is the command code for the slave to undertake the following action types.

Type	Function Code	Sub-Function Code	Contents
Diagnostics	08 (08H)	00 (0000H)	Echoes back the request message.
	43 (2BH)	14 (0EH)	Reads device identification information.

Function code is used to discern whether the response is normal (acknowledgement) or if any error (negative acknowledgement) has occurred when the slave returns the response message to the master.

When acknowledgement is returned, the slave simply returns the original function code.

When negative acknowledgement is returned, the MSB of the original function code is set as 1 for the response.

For example, when the master sends request message setting 0FH to the sub-function code by mistake, slave returns ABH by setting the MSB to 1, because the former is a non-existent sub-function code.

For negative acknowledgement, the exception codes below are set to the data of the response message, and returned to the master in order to inform it of what kind of error has occurred.

Exception Code	Contents
1 (01H)	Illegal function (Non-existent function) Sub-function code is not correct.
2 (02H)	Illegal data address (Non-existent data address) For function code 43: Object ID is any value other than 00, 01, 02.
3 (03H)	Illegal data value (Value out of the setting range) For function code 08: Data is less than 1, or has exceeded 100. For function code 43: Read Device ID code is any value other than 01, 04.

#### (3) Data

Data differs depending on the function code.

For the Function code 08 (08H), a request message from the master side is composed of 'Sub-function code 2 Bytes (0000H)' and 'Data n x 2 Bytes'. [n: Amount of data (Max. 100)]

In normal status, a response message from the slave side is the same as the request message.

Function code	1 Byte	08H
Sub-function code	1 Byte	0000H fixed
Data	n x 2 Bytes	Random value (Max. 100)

For Function code 43 (2BH), the request message from the master side is composed of Sub-function code 14 (0EH), Read Device ID code and Object ID.

Function code	1 Byte	2BH	
Sub-function code (MEI type)	1 Byte	0EH	
Read Device ID code (Corresponds to Basic category)	1 Byte	01H/04H	
Object ID	1 Byte	00	Vendor name SHINKO TECHNOS CO., LTD.
		01	Product code (model) (e.g.) DCL-33A-R/M
		02	Version number (D, T, MP) (e.g.) Dxx-xxxx-xx, MPxxxx-xx

Response message from the slave is composed of Sub-function code 14 (0EH) (for request), Read Device ID code and Object ID.

Function code	1 Byte	2BH	
Sub-function code (MEI type)	1 Byte	0EH	
Data	Read Device ID code	1 Byte	01H/04H
	Conformity level	1 Byte	01H/81H
	More Follows	1 Byte	00H/FFH
	Next Object ID	1 Byte	Object ID number
	Number of Objects	1 Byte	
	List of Object ID	1 Byte	
	List of Object length	1 Byte	
	List of Object value	Object length	

For the response message (negative acknowledgement), an exception code is set and returned.

Function code	1 Byte	ABH
Exception code	1 Byte	01H/02H/03H

#### (4) Error check

16-bit data to detect communication errors.

Refer to Section '6.3 Message Configuration (4) Error Check (pp.12, 13).

### 6.5.2 Message Example

Message example in RTU mode are shown below.

Numerals written below the message represent the number of characters.

#### (1) Echo back Slave address 1, Request message

- A request message from the master [Test data 200 (00C8H), 60 (003CH), 10 (000AH)]

3.5 idle characters	Slave address (01H)	Function code (08H)	Sub-function code (0000H)	Data (00C8003C000AH)	Error check CRC-16 (E7D9H)	3.5 idle characters
	1	1	2	n x 2	2	

- Response message from the slave in normal status (Echoes back the same message.)

3.5 idle characters	Slave address (01H)	Function code (08H)	Sub-function code (0000H)	Data (00C8003C000AH)	Error check CRC-16 (E7D9H)	3.5 idle characters
	1	1	2	n x 2	2	

**(2) Read Slave address 1, Device identification information (Vendor name)**

- A request message from the master

3.5 idle characters	Slave address (01H)	Function code (2BH)	Sub-function code (0EH)	Data (0400H)	Error check CRC-16 (7327H)	3.5 idle characters
	1	1	1	2	2	

- Response message from the slave in normal status (SHINKO TECHNOS CO., LTD.)

3.5 idle characters	Slave address (01H)	Function code (2BH)	Sub-function code (0EH)
	1	1	1

Data
(048100000100185348494E4B4F20544543484E4F5320434F2E2C204C54442EH)
31

Error check CRC-16 (1C54H)	3.5 idle characters
2	

Data in the response message becomes as follows.

Data	Read Device ID code	1 Byte	04H
	Conformity level	1 Byte	81H
	More Follows	1 Byte	00H
	Next Object ID	1 Byte	00H
	Number of Objects	1 Byte	01H
	List of Object ID	1 Byte	00H
	List of Object length	1 Byte	24(18H)
	List of Object value	Object length	S(53H)
			H(48H)
			I(49H)
			N(4EH)
			K(4BH)
			O(4FH)
			(20H)
			T(54H)
			E(45H)
			C(43H)
			H(48H)
			N(4EH)
			O(4FH)
			S(53H)
			(20H)
			C(43H)
			O(4FH)
			.(2EH)
			,(2CH)
		(20H)	
		L(4CH)	
		T(54H)	
		D(44H)	
		.(2EH)	

### (3) Read Slave address 1, Device identification information (Product code)

- A request message from the master

3.5 idle characters	Slave address (01H)	Function code (2BH)	Sub-function code (0EH)	Data (0401H)	Error check CRC-16 (B2E7H)	3.5 idle characters
	1	1	1	2	2	

- Response message from the slave in normal status (DCL-33A-R/M)

3.5 idle characters	Slave address (01H)	Function code (2BH)	Sub-function code (0EH)			
	1	1	1			
				Data	Error check CRC-16	3.5 idle characters
				(0481000001010B44434C2D3333412D522F4DH)	(8EF3H)	
				18	2	

Data in the response message becomes as follows.

Data	Read Device ID code	1 Byte	04H
	Conformity level	1 Byte	81H
	More Follows	1 Byte	00H
	Next Object ID	1 Byte	00H
	Number of Objects	1 Byte	01H
	List of Object ID	1 Byte	01H
	List of Object length	1 Byte	11(0BH)
	List of Object value	Object length	D(44H)
			C(43H)
			L(4CH)
			-(2DH)
			3(33H)
			3(33H)
			A(41H)
			-(2DH)
			R(52H)
		/ (2FH)	
		M(4DH)	

- Response message from the slave in exception (error) status [when Sub-function code (MEI type) is incorrect]

The function code MSB is set to 1 for the response message in exception (error) status, and ABH is returned.

Exception code 01H (Non-existent function) is returned (error).

3.5 idle characters	Slave address (01H)	Function code (ABH)	Exception code (01H)	Error check CRC-16 (9EF0H)	3.5 idle characters
	1	1	1	2	

# 7. Communication Command Table

## 7.1 Shinko Protocol, MODBUS ASCII Mode, MODBUS RTU Mode Commands

### 7.1.1 A Single Piece of Data Read/Write Command

Shinko Command Type	MODBUS Function Code	Data Item		Data
20H/50H	03H/06H	0001H	SV1	Set value
20H/50H	03H/06H	0003H	AT Perform/Cancel	0000H: AT Cancel 0001H: AT Perform
20H/50H	03H/06H	0004H	OUT1 proportional band	Set value
20H/50H	03H/06H	0005H	OUT2 proportional band	Set value
20H/50H	03H/06H	0006H	Integral time	Set value
20H/50H	03H/06H	0007H	Derivative time	Set value
20H/50H	03H/06H	0008H	OUT1 proportional cycle	Set value
20H/50H	03H/06H	0009H	OUT2 proportional cycle	Set value
20H/50H	03H/06H	000AH	Manual reset	Set value
20H/50H	03H/06H	000BH	Alarm 1 value	Set value
20H/50H	03H/06H	000FH	Heater burnout alarm value	Set value
20H/50H	03H/06H	0010H	Loop break alarm time	Set value
20H/50H	03H/06H	0011H	Loop break alarm band	Set value
20H/50H	03H/06H	0012H	Set value lock	0000H: Unlock 0001H: Lock 1 0002H: Lock 2 0003H: Lock 3
20H/50H	03H/06H	0015H	Sensor correction	Set value
20H/50H	03H/06H	0016H	Overlap/Dead band	Set value
20H/50H	03H/06H	0018H	Scaling high limit	Set value
20H/50H	03H/06H	0019H	Scaling low limit	Set value
20H/50H	03H/06H	001AH	Decimal point place	0000H: XXXX (No decimal point) 0001H: XXX.X (1 digit after decimal point) 0002H: XX.XX (2 digits after decimal point) 0003H: X.XXX (3 digits after decimal point)
20H/50H	03H/06H	001BH	PV filter time constant	Set value
20H/50H	03H/06H	001CH	OUT1 high limit	Set value
20H/50H	03H/06H	001DH	OUT1 low limit	Set value
20H/50H	03H/06H	001EH	OUT1 ON/OFF hysteresis	Set value
20H/50H	03H/06H	001FH	OUT2 cooling method	0000H: Air cooling (Linear characteristic) 0001H: Oil cooling (1.5th power of the linear characteristic) 0002H: Water cooling (2nd power of the linear characteristic)
20H/50H	03H/06H	0020H	OUT2 high limit	Set value
20H/50H	03H/06H	0021H	OUT2 low limit	Set value
20H/50H	03H/06H	0022H	OUT2 ON/OFF hysteresis	Set value
20H/50H	03H/06H	0023H	Alarm 1 type	0000H: No alarm action 0001H: High limit alarm 0002H: Low limit alarm 0003H: High/Low limits alarm 0004H: High/Low limit range alarm 0005H: Process high alarm 0006H: Process low alarm 0007H: High limit with standby alarm 0008H: Low limit with standby alarm 0009H: High/Low limits with standby

Shinko Command Type	MODBUS Function Code	Data Item		Data
20H/50H	03H/06H	0023H	Alarm 1 type	000AH: High/Low limits independent 000BH: High/Low limit range independent 000CH: High/Low limits with standby independent
20H/50H	03H/06H	0025H	Alarm 1 hysteresis	Set value
20H/50H	03H/06H	0029H	Alarm 1 delay time	Set value
20H/50H	03H/06H	0040H	Alarm 1 Energized/De-energized	0000H: Energized 0001H: De-energized
20H/50H	03H/06H	0042H	Alarm 1 HOLD function	0000H: Not holding 0001H: Holding
20H/50H	03H/06H	0044H	Input type	0000H: K [-200 to 1370°C] 0001H: K [-199.9 to 400.0°C] 0002H: J [-200 to 1000°C] 0003H: R [0 to 1760°C] 0004H: S [0 to 1760°C] 0005H: B [0 to 1820°C] 0006H: E [-200 to 800°C] 0007H: T [-199.9 to 400.0°C] 0008H: N [-200 to 1300°C] 0009H: PL-II [0 to 1390°C] 000AH: C (W/Re5-26) [0 to 2315°C] 000BH: Pt100 [-199.9 to 850.0°C] 000CH: JPt100 [-199.9 to 500.0°C] 000DH: Pt100 [-200 to 850°C] 000EH: JPt100 [-200 to 500°C] 000FH: K [-320 to 2500°F] 0010H: K [-199.9 to 750.0°F] 0011H: J [-320 to 1800°F] 0012H: R [0 to 3200°F] 0013H: S [0 to 3200°F] 0014H: B [0 to 3300°F] 0015H: E [-320 to 1500°F] 0016H: T [-199.9 to 750.0°F] 0017H: N [-320 to 2300°F] 0018H: PL-II [0 to 2500°F] 0019H: C (W/Re5-26) [0 to 4200°F] 001AH: Pt100 [-199.9 to 999.9°F] 001BH: JPt100 [-199.9 to 900.0°F] 001CH: Pt100 [-300 to 1500°F] 001DH: JPt100 [-300 to 900°F] 001EH: 4 to 20 mA DC [-1999 to 9999] (Externally mounted shunt resistor) 001FH: 0 to 20mA DC [-1999 to 9999] (Externally mounted shunt resistor) 0020H: 0 to 1 V DC [-1999 to 9999] 0021H: 0 to 5 V DC [-1999 to 9999] 0022H: 1 to 5 V DC [-1999 to 9999] 0023H: 0 to 10 V DC [-1999 to 9999] 0024H: 0 to 20 mA DC [-1999 to 9999] (Built-in shunt resistor) 0025H: 0 to 20mA DC [-1999 to 9999] (Built-in shunt resistor)
20H/50H	03H/06H	0045H	Direct/Reverse action	0000H: Heating (Reverse action) 0001H: Cooling (Direct action)
20H/50H	03H/06H	0047H	AT bias	Set value
20H/50H	03H/06H	0048H	ARW	Set value
20H/50H	03H/06H	006FH	Key lock	0000H: Key Enabled 0001H: Key Locked



### 7.1.2 A Single Piece of Data Write Command

Shinko Command Type	MODBUS Function Code	Data Item		Data
50H	06H	0070H	Key operation change flag clearing	0000H: No action 0001H: Clear key operation change flag

### 7.1.3 A Single Piece of Data Read Command

Shinko Command Type	MODBUS Function Code	Data Item		Data
20H	03H	0080H	PV	PV (Process variable)
20H	03H	0081H	OUT1 MV (MV1)	Current OUT1 MV (MV1)
20H	03H	0082H	OUT2 MV (MV2)	Current OUT2 MV (MV2)
20H	03H	0085H	Status flag	<p>0000 0000 0000 0000  <math>2^{15}</math> to <math>2^0</math></p> <p> <math>2^0</math> digit: OUT1                      0: OFF 1: ON  <math>2^1</math> digit: Not used (Always 0)  <math>2^2</math> digit: Alarm 1 output                      0: OFF 1: ON  <math>2^3</math> to <math>2^5</math> digits: Not used (Always 0)  <math>2^6</math> digit: Heater burnout alarm output                      0: OFF 1: ON                      (For sensor burnout, 0: OFF)  <math>2^7</math> digit: Loop break alarm output                      0: OFF 1: ON  <math>2^8</math> digit: Overscale                      0: OFF 1: ON  <math>2^9</math> digit: Underscale                      0: OFF 1: ON  <math>2^{10}</math> digit: Not used (Always 0)  <math>2^{11}</math> digit: During AT                      0: OFF 1: During AT  <math>2^{12}</math> digit: Not used (Always 0)  <math>2^{13}</math> digit: Controller/Converter                      0: Controller 1: Converter  <math>2^{14}</math> digit: Not used (Always 0)  <math>2^{15}</math> digit: Change in key operation                      0: No 1: Yes</p>

**7.2 Shinko Protocol (Block Read/Write available), MODBUS ASCII Mode (Block Read/Write available), MODBUS RTU Mode (Block Read/Write available) Commands**

**7.2.1 A Single/Multiple Piece(s) of Data Read/Write Command**

Shinko Command Type	MODBUS Function Code	Data Item		Data
20H/24H/50H/54H	03H/06H/10H	0001H	SV1	Set value
20H/24H/50H/54H	03H/06H/10H	0002H	Input type	0000H: K [-200 to 1370°C] 0001H: K [-199.9 to 400.0°C] 0002H: J [-200 to 1000°C] 0003H: R [0 to 1760°C] 0004H: S [0 to 1760°C] 0005H: B [0 to 1820°C] 0006H: E [-200 to 800°C] 0007H: T [-199.9 to 400.0°C] 0008H: N [-200 to 1300°C] 0009H: PL-II [0 to 1390°C] 000AH: C (W/Re5-26) [0 to 2315°C] 000BH: Pt100 [-199.9 to 850.0°C] 000CH: JPt100 [-199.9 to 500.0°C] 000DH: Pt100 [-200 to 850°C] 000EH: JPt100 [-200 to 500°C] 000FH: K [-320 to 2500°F] 0010H: K [-199.9 to 750.0°F] 0011H: J [-320 to 1800°F] 0012H: R [0 to 3200°F] 0013H: S [0 to 3200°F] 0014H: B [0 to 3300°F] 0015H: E [-320 to 1500°F] 0016H: T [-199.9 to 750.0°F] 0017H: N [-320 to 2300°F] 0018H: PL-II [0 to 2500°F] 0019H: C (W/Re5-26) [0 to 4200°F] 001AH: Pt100 [-199.9 to 999.9°F] 001BH: JPt100 [-199.9 to 900.0°F] 001CH: Pt100 [-300 to 1500°F] 001DH: JPt100 [-300 to 900°F] 001EH: 4 to 20 mA DC [-1999 to 9999] (Externally mounted shunt resistor) 001FH: 0 to 20 mA DC [-1999 to 9999] (Externally mounted shunt resistor) 0020H: 0 to 1 V DC [-1999 to 9999] 0021H: 0 to 5 V DC [-1999 to 9999] 0022H: 1 to 5 V DC [-1999 to 9999] 0023H: 0 to 10 V DC [-1999 to 9999] 0024H: 0 to 20 mA DC [-1999 to 9999] (Built-in shunt resistor) 0025H: 0 to 20 mA DC [-1999 to 9999] (Built-in shunt resistor)
20H/24H/50H/54H	03H/06H/10H	0003H	Scaling high limit	Set value
20H/24H/50H/54H	03H/06H/10H	0004H	Scaling low limit	Set value
20H/24H/50H/54H	03H/06H/10H	0005H	Decimal point place	0000H: XXXX (No decimal point) 0001H: XXX.X (1 digit after decimal point) 0002H: XX.XX (2 digits after decimal point) 0003H: X.XXX (3 digits after decimal point)

Shinko Command Type	MODBUS Function Code	Data Item		Data
20H/24H/50H/54H	03H/06H/10H	0006H	Alarm 1 type	0000H: No alarm action 0001H: High limit alarm 0002H: Low limit alarm 0003H: High/Low limits alarm 0004H: High/Low limit range alarm 0005H: Process high alarm 0006H: Process low alarm 0007H: High limit with standby alarm 0008H: Low limit with standby alarm 0009H: High/Low limits with standby 000AH: High/Low limits independent 000BH: High/Low limit range independent 000CH: High/Low limits with standby independent
20H/24H/50H/54H	03H/06H/10H	0007H	Alarm 2 type	0000H: No alarm action 0001H: High limit alarm 0002H: Low limit alarm 0003H: High/Low limits alarm 0004H: High/Low limit range alarm 0005H: Process high alarm 0006H: Process low alarm 0007H: High limit with standby alarm 0008H: Low limit with standby alarm 0009H: High/Low limits with standby 000AH: High/Low limits independent 000BH: High/Low limit range independent 000CH: High/Low limits with standby independent
20H/24H/50H/54H	03H/06H/10H	0008H	Alarm 3 type	0000H: No alarm action 0001H: High limit alarm 0002H: Low limit alarm 0003H: High/Low limits alarm 0004H: High/Low limit range alarm 0005H: Process high alarm 0006H: Process low alarm 0007H: High limit with standby alarm 0008H: Low limit with standby alarm 0009H: High/Low limits with standby 000AH: High/Low limits independent 000BH: High/Low limit range independent 000CH: High/Low limits with standby independent
20H/24H/50H/54H	03H/06H/10H	0009H	Alarm 4 type	0000H: No alarm action 0001H: High limit alarm 0002H: Low limit alarm 0003H: High/Low limits alarm 0004H: High/Low limit range alarm 0005H: Process high alarm 0006H: Process low alarm 0007H: High limit with standby alarm 0008H: Low limit with standby alarm 0009H: High/Low limits with standby 000AH: High/Low limits independent 000BH: High/Low limit range independent 000CH: High/Low limits with standby independent
20H/24H/50H/54H	03H/06H/10H	000AH	Reserved (*1)	

Shinko Command Type	MODBUS Function Code	Data Item		Data
20H/24H/50H/54H	03H/06H/10H	000BH	Reserved (*1)	
20H/24H/50H/54H	03H/06H/10H	000CH	Reserved (*1)	
20H/24H/50H/54H	03H/06H/10H	000DH	Reserved (*1)	
20H/24H/50H/54H	03H/06H/10H	000EH	SV1	Set value
20H/24H/50H/54H	03H/06H/10H	000FH	SV2	Set value
20H/24H/50H/54H	03H/06H/10H	0010H	Reserved (*1)	
20H/24H/50H/54H	03H/06H/10H	0011H	Reserved (*1)	
20H/24H/50H/54H	03H/06H/10H	0012H	Alarm 1 value	Set value
20H/24H/50H/54H	03H/06H/10H	0013H	Alarm 1 high limit alarm value	Set value
20H/24H/50H/54H	03H/06H/10H	0014H	Alarm 2 value	Set value
20H/24H/50H/54H	03H/06H/10H	0015H	Alarm 2 high limit alarm value	Set value
20H/24H/50H/54H	03H/06H/10H	0016H	Alarm 3 value	Set value
20H/24H/50H/54H	03H/06H/10H	0017H	Alarm 3 high limit alarm value	Set value
20H/24H/50H/54H	03H/06H/10H	0018H	Alarm 4 value	Set value
20H/24H/50H/54H	03H/06H/10H	0019H	Alarm 4 high limit alarm value	Set value
20H/24H/50H/54H	03H/06H/10H	001AH	Reserved (*1)	
20H/24H/50H/54H	03H/06H/10H	001BH	Reserved (*1)	
20H/24H/50H/54H	03H/06H/10H	001CH	Heater burnout alarm value	Set value
20H/24H/50H/54H	03H/06H/10H	001DH	Reserved (*1)	
20H/24H/50H/54H	03H/06H/10H	001EH	Loop break alarm time	Set value
20H/24H/50H/54H	03H/06H/10H	001FH	Loop break alarm band	Set value
20H/24H/50H/54H	03H/06H/10H	0020H	Event input DI allocation	0000H: No event 0001H: Set value memory 0002H: Control ON/OFF 0003H: Direct/Reverse action 0004H: Preset output 1 ON/OFF 0005H: Preset output 2 ON/OFF 0006H: Auto/Manual control 0007H: Integral action Holding/ Usual integral action 0008H: Set value memory 0009H: Control ON/OFF 000AH: Direct/Reverse action 000BH: Preset output 1 ON/OFF 000CH: Preset output 2 ON/OFF 000DH: Auto/Manual control 000EH: Integral action Holding/ Usual integral action
20H/24H/50H/54H	03H/06H/10H	0021H	Reserved (*1)	
20H/24H/50H/54H	03H/06H/10H	0022H	Reserved (*1)	
20H/24H/50H/54H	03H/06H/10H	0023H	Reserved (*1)	

Shinko Command Type	MODBUS Function Code	Data Item		Data
20H/24H/50H/54H	03H/06H/10H	0024H	Alarm 1 value 0 Enabled/Disabled	0000H: Disabled 0001H: Enabled
20H/24H/50H/54H	03H/06H/10H	0025H	Alarm 1 hysteresis	Set value
20H/24H/50H/54H	03H/06H/10H	0026H	Alarm 1 delay time	Set value
20H/24H/50H/54H	03H/06H/10H	0027H	Alarm 1 Energized/ De-energized	0000H: Energized 0001H: De-energized
20H/24H/50H/54H	03H/06H/10H	0028H	Alarm 2 value 0 Enabled/Disabled	0000H: Disabled 0001H: Enabled
20H/24H/50H/54H	03H/06H/10H	0029H	Alarm 2 hysteresis	Set value
20H/24H/50H/54H	03H/06H/10H	002AH	Alarm 2 delay time	Set value
20H/24H/50H/54H	03H/06H/10H	002BH	Alarm 2 Energized/ De-energized	0000H: Energized 0001H: De-energized
20H/24H/50H/54H	03H/06H/10H	002CH	Alarm 3 value 0 Enabled/Disabled	0000H: Disabled 0001H: Enabled
20H/24H/50H/54H	03H/06H/10H	002DH	Alarm 3 hysteresis	Set value
20H/24H/50H/54H	03H/06H/10H	002EH	Alarm 3 delay time	Set value
20H/24H/50H/54H	03H/06H/10H	002FH	Alarm 3 Energized/ De-energized	0000H: Energized 0001H: De-energized
20H/24H/50H/54H	03H/06H/10H	0030H	Alarm 4 value 0 Enabled/Disabled	0000H: Disabled 0001H: Enabled
20H/24H/50H/54H	03H/06H/10H	0031H	Alarm 4 hysteresis	Set value
20H/24H/50H/54H	03H/06H/10H	0032H	Alarm 4 delay time	Set value
20H/24H/50H/54H	03H/06H/10H	0033H	Alarm 4 Energized/ De-energized	0000H: Energized 0001H: De-energized
20H/24H/50H/54H	03H/06H/10H	0034H	Reserved (*1)	
20H/24H/50H/54H	03H/06H/10H	0035H	Reserved (*1)	
20H/24H/50H/54H	03H/06H/10H	0036H	Reserved (*1)	
20H/24H/50H/54H	03H/06H/10H	0037H	Reserved (*1)	
20H/24H/50H/54H	03H/06H/10H	0038H	Reserved (*1)	
20H/24H/50H/54H	03H/06H/10H	0039H	Reserved (*1)	
20H/24H/50H/54H	03H/06H/10H	003AH	Reserved (*1)	
20H/24H/50H/54H	03H/06H/10H	003BH	Reserved (*1)	
20H/24H/50H/54H	03H/06H/10H	003CH	OUT1 proportional band	Set value
20H/24H/50H/54H	03H/06H/10H	003DH	Integral time	Set value
20H/24H/50H/54H	03H/06H/10H	003EH	Derivative time	Set value
20H/24H/50H/54H	03H/06H/10H	003FH	ARW	Set value
20H/24H/50H/54H	03H/06H/10H	0040H	Manual reset	Set value
20H/24H/50H/54H	03H/06H/10H	0041H	OUT1 proportional cycle	Set value
20H/24H/50H/54H	03H/06H/10H	0042H	OUT1 ON/OFF hysteresis	Set value
20H/24H/50H/54H	03H/06H/10H	0043H	OUT1 high limit	Set value
20H/24H/50H/54H	03H/06H/10H	0044H	OUT1 low limit	Set value
20H/24H/50H/54H	03H/06H/10H	0045H	Reserved (*1)	

Shinko Command Type	MODBUS Function Code	Data Item		Data
20H/24H/50H/54H	03H/06H/10H	0046H	OUT2 cooling method	0000H: Air cooling (Linear characteristic) 0001H: Oil cooling (1.5 <sup>th</sup> power of the linear characteristic) 0002H: Water cooling (2 <sup>nd</sup> power of the linear characteristic)
20H/24H/50H/54H	03H/06H/10H	0047H	OUT2 proportional band	Set value
20H/24H/50H/54H	03H/06H/10H	0048H	OUT2 proportional cycle	Set value
20H/24H/50H/54H	03H/06H/10H	0049H	OUT2 ON/OFF hysteresis	Set value
20H/24H/50H/54H	03H/06H/10H	004AH	OUT2 high limit	Set value
20H/24H/50H/54H	03H/06H/10H	004BH	OUT2 low limit	Set value
20H/24H/50H/54H	03H/06H/10H	004CH	Overlap/Dead band	Set value
20H/24H/50H/54H	03H/06H/10H	004DH	Direct/Reverse action	0000H: Heating (Reverse action) 0001H: Cooling (Direct action)
20H/24H/50H/54H	03H/06H/10H	004EH	Set value lock	0000H: Unlock 0001H: Lock 1 0002H: Lock 2 0003H: Lock 3
20H/24H/50H/54H	03H/06H/10H	004FH	Reserved (*1)	
20H/24H/50H/54H	03H/06H/10H	0050H	Sensor correction	Set value
20H/24H/50H/54H	03H/06H/10H	0051H	PV filter time constant	Set value
20H/24H/50H/54H	03H/06H/10H	0052H	Reserved (*1)	
20H/24H/50H/54H	03H/06H/10H	0053H	SVTC bias	Set value
20H/24H/50H/54H	03H/06H/10H	0054H	External setting input high limit	Set value
20H/24H/50H/54H	03H/06H/10H	0055H	External setting input low limit	Set value
20H/24H/50H/54H	03H/06H/10H	0056H	Remote bias	Set value
20H/24H/50H/54H	03H/06H/10H	0057H	SV Rise/Fall rate start type	0000H: SV start 0001H: PV start
20H/24H/50H/54H	03H/06H/10H	0058H	SV rise rate	Set value
20H/24H/50H/54H	03H/06H/10H	0059H	SV fall rate	Set value
20H/24H/50H/54H	03H/06H/10H	005AH	Reserved (*1)	
20H/24H/50H/54H	03H/06H/10H	005BH	AT bias	Set value
20H/24H/50H/54H	03H/06H/10H	005CH	Output status when input errors occur	0000H: Output OFF 0001H: Output ON
20H/24H/50H/54H	03H/06H/10H	005DH	Auto/Manual after power ON	0000H: Automatic control 0001H: Manual control
20H/24H/50H/54H	03H/06H/10H	005EH	Reserved (*1)	
20H/24H/50H/54H	03H/06H/10H	005FH	OUT1 MV preset value	Set value
20H/24H/50H/54H	03H/06H/10H	0060H	OUT2 MV preset value	Set value
20H/24H/50H/54H	03H/06H/10H	0061H	Alarm 1 HOLD function	0000H: Not holding 0001H: Holding
20H/24H/50H/54H	03H/06H/10H	0062H	Alarm 2 HOLD function	0000H: Not holding 0001H: Holding

<b>Shinko Command Type</b>	<b>MODBUS Function Code</b>	<b>Data Item</b>		<b>Data</b>
20H/24H/50H/54H	03H/06H/10H	0063H	Alarm 3 HOLD function	0000H: Not holding 0001H: Holding
20H/24H/50H/54H	03H/06H/10H	0064H	Alarm 4 HOLD function	0000H: Not holding 0001H: Holding
20H/24H/50H/54H	03H/06H/10H	0065H	Reserved (*1)	
:	:	:	:	
20H/24H/50H/54H	03H/06H/10H	008CH	Reserved (*1)	
20H/24H/50H/54H	03H/06H/10H	008DH	Not used (*2)	
:	:	:	:	
20H/24H/50H/54H	03H/06H/10H	00DFH	Not used (*2)	

### 7.2.2 A Single Piece of Data Read/Write Command

Shinko Command Type	MODBUS Function Code	Data Item		Data
20H/50H	03H/06H	00E0H	SUB-MODE key function	0000H: Control output OFF function 0001H: Auto/Manual control 0002H: Alarm HOLD cancel
20H/50H	03H/06H	00E1H	Remote/Local	0000H: Local 0001H: Remote
20H/50H	03H/06H	00E2H	Control output OFF function, Auto/Manual control, or Alarm HOLD cancel	Control output OFF function 0000H: Control output ON 0001H: Control output OFF Auto/Manual control 0000H: Automatic control 0001H: Manual control Alarm HOLD cancel 0000H: No action 0001H: Alarm HOLD cancel
20H/50H	03H/06H	00E3H	Reserved (*1)	
20H/50H	03H/06H	00E4H	Reserved (*1)	
20H/50H	03H/06H	00E5H	Manual control MV (*3)	Set value
20H/50H	03H/06H	00E6H	AT Perform/Cancel	0000H: AT Cancel 0001H: AT Perform
20H/50H	03H/06H	00E7H	Controller/Converter	0000H: Controller 0001H: Converter
20H/50H	03H/06H	00E8H	Reserved (*1)	
20H/50H	03H/06H	00E9H	Reserved (*1)	
20H/50H	03H/06H	00EAH	Control output OUT1/EVT	0000H: OUT1 0001H: EVT
20H/50H	03H/06H	00EBH	Heater burnout alarm output Enabled/Disabled	0000H: Disabled 0001H: Enabled
20H/50H	03H/06H	00ECH	Loop break alarm output Enabled/Disabled	0000H: Disabled 0001H: Enabled
20H/50H	03H/06H	00EDH	Alarm 1 output Enabled/Disabled	0000H: Disabled 0001H: Enabled
20H/50H	03H/06H	00EEH	Alarm 2 output Enabled/Disabled	0000H: Disabled 0001H: Enabled
20H/50H	03H/06H	00EFH	Alarm 3 output Enabled/Disabled	0000H: Disabled 0001H: Enabled
20H/50H	03H/06H	00F0H	Alarm 4 output Enabled/Disabled	0000H: Disabled 0001H: Enabled
20H/50H	03H/06H	00F1H	Not used (*2)	
:	:	:	:	
20H/50H	03H/06H	00FDH	Not used (*2)	
20H/50H	03H/06H	00FEH	Reserved (*1)	

### 7.2.3 A Single Piece of Data Write Command

Shinko Command Type	MODBUS Function Code	Data Item		Data
50H	06H	00FFH	Key operation change flag clearing (*4)	0000H: No action 0001H: Clear key operation change flag



### 7.2.4 A Single/Multiple Piece(s) of Data Read Command

Shinko Command Type	Modbus Function Code	Data Item		Data
20H/24H	03H/04H	0100H	PV	PV (Process variable)
20H/24H	03H/04H	0101H	OUT1 MV (MV1)	Current OUT1 MV (MV1)
20H/24H	03H/04H	0102H	OUT2 MV (MV2)	Current OUT2 MV (MV2)
20H/24H	03H/04H	0103H	Current SV	Current SV (desired value)
20H/24H	03H/04H	0104H	Reserved (*1)	
20H/24H	03H/04H	0105H	Reserved (*1)	
20H/24H	03H/04H	0106H	Reserved (*1)	
20H/24H	03H/04H	0107H	Reserved (*1)	
20H/24H	03H/04H	0108H	Reserved (*1)	
20H/24H	03H/04H	0109H	CT1 current value	CT1 current value (current value when OUT1 is ON)
20H/24H	03H/04H	010AH	Reserved (*1)	
20H/24H	03H/04H	010BH	Reserved (*1)	
20H/24H	03H/04H	010CH	Reserved (*1)	
20H/24H	03H/04H	010DH	Status flag 1	0000 0000 0000 0000 $2^{15}$ to $2^0$  2 <sup>0</sup> digit: OUT1 0: OFF 1: ON (Current output: Unfixed) 2 <sup>1</sup> digit: OUT2 0: OFF 1: ON (Current output: Unfixed) 2 <sup>2</sup> digit: Alarm 1 output 0: OFF 1: ON 2 <sup>3</sup> digit: Alarm 2 output 0: OFF 1: ON 2 <sup>4</sup> digit: Alarm 3 output 0: OFF 1: ON 2 <sup>5</sup> digit: Alarm 4 output 0: OFF 1: ON 2 <sup>6</sup> digit: Heater burnout alarm output 0: OFF 1: ON (When sensor burnout, 0: OFF) 2 <sup>7</sup> digit: Loop break alarm output 0: OFF 1: ON 2 <sup>8</sup> digit: Oversclae 0: OFF 1: ON 2 <sup>9</sup> digit: Undersclae 0: OFF 1: ON 2 <sup>10</sup> digit: Not used (Always 0) 2 <sup>11</sup> digit: During AT 0: OFF 1: During AT 2 <sup>12</sup> digit: Not used (Always 0) 2 <sup>13</sup> digit: Controller/Converter 0: Controller 1: Converter 2 <sup>14</sup> digit: Not used (Always 0) 2 <sup>15</sup> digit: Change in key operation 0: No 1: Yes

Shinko Command Type	MODBUS Function Code	Data Item		Data
20H/24H	03H/04H	010EH	Status flag 2	0000 0000 0000 0000 $2^{15}$ to $2^0$ 2 <sup>0</sup> digit: Event input DI1 0: OFF 1: ON 2 <sup>1</sup> to 2 <sup>5</sup> digits: Reserved 2 <sup>6</sup> digit: Unit status 0: PV/SV Display mode 1: Setting mode 2 <sup>7</sup> digit: Warm-up 0: Finished 1: Warm-up 2 <sup>8</sup> to 2 <sup>9</sup> digits: Reserved 2 <sup>10</sup> digit: Auto/Manual control 0: Automatic 1: Manual 2 <sup>11</sup> to 2 <sup>15</sup> digits: Reserved
20H/24H	03H/04H	010FH	Reserved (*1)	
20H/24H	03H/04H	0110H	Reserved (*1)	
20H/24H	03H/04H	0111H	Software version	Software version No.
20H/24H	03H/04H	0112H	Unit model information 1	0000 0000 0000 0000 $2^{15}$ to $2^0$ 2 <sup>0</sup> digit: Event input DI1 Enabled/Disabled 0: Disabled 1: Enabled 2 <sup>1</sup> digit: External setting input Enabled/Disabled 0: Disabled 1: Enabled 2 <sup>2</sup> digit: Alarm 1 function Enabled/Disabled 0: Disabled 1: Enabled 2 <sup>3</sup> digit: Alarm 2 function Enabled/Disabled 0: Disabled 1: Enabled 2 <sup>4</sup> digit: Alarm 3 function Enabled/Disabled 0: Disabled 1: Enabled 2 <sup>5</sup> digit: Alarm 4 function Enabled/Disabled 0: Disabled 1: Enabled 2 <sup>6</sup> digit: Heater burnout alarm output Enabled/Disabled 0: Disabled 1: Enabled 2 <sup>7</sup> digit: Loop break alarm output Enabled/Disabled 0: Disabled 1: Enabled 2 <sup>8</sup> digit: Heater burnout alarm output rated current (5A) 0: 10A, 20A, 50A 1: 5A 2 <sup>9</sup> digit: Heater burnout alarm output rated current (10A) 0: 5A, 20A, 50A 1: 10A 2 <sup>10</sup> digit: Heater burnout alarm output rated current (20A) 0: 5A, 10A, 50A 1: 20A 2 <sup>11</sup> digit: Heater burnout alarm output rated current (50A) 0: 5A, 10A, 20A 1: 50A 2 <sup>12</sup> to 2 <sup>15</sup> digits: Not used (Always 0)

Shinko Command Type	MODBUS Function Code	Data Item		Data
20H/24H	03H/04H	0113H	Unit model information 2	0000 0000 0000 0000 $2^{15}$ to $2^0$  2 <sup>0</sup> to 2 <sup>2</sup> digits: Model 0: xxD 1: xxR (Vertical type) 2: xxM 3: xxS 4: xxL 5: xxR (Horizontal type) 2 <sup>3</sup> to 2 <sup>4</sup> digits: OUT1 output type 0: R/M (Relay contact) 1: S/M (Non-contact voltage) 2: A/M (Direct current) 2 <sup>5</sup> to 2 <sup>15</sup> digits: Not used (Always 0)

(\*1) For 'Reserved' items, if a Single/Multiple piece(s) of data Read is/are executed, acknowledgement will be returned (but data is 0).

If a Single/Multiple piece(s) of data Write is/are executed, acknowledgement will be returned, and data will be discarded.

(\*2) For 'Not used' items, if a Single/Multiple piece(s) of data Read/Write is executed, Error code 1 (31H, Shinko protocol) or Exception code 2 (02H, MODBUS protocol) will be returned.

(\*3) For 00E5H (Manual control MV), if Write is executed for the following, Error code 3 (33H, Shinko protocol) or Exception code 3 (03H, MODBUS protocol) will be returned:

- For ON/OFF control action, if Write is executed for any value other than OUT1 low limit value, OUT1 high limit value
- When Heating side (in Heating/Cooling control) is ON/OFF control, and if Write is executed for any value other than OUT1 low limit value, OUT1 high limit value on Heating side, or if Write is executed for any value other than OUT2 low limit value, OUT2 high limit value on Cooling side
- When Cooling side (in Heating/Cooling control) is ON/OFF control, and if Write is executed for any value other than [from OUT1 low limit value to OUT1 high limit value] on Heating side, or if Write is executed for any value other than OUT2 low limit value, OUT2 high limit value on Cooling side

(\*4) For 00FFH (Key operation change flag clearing), if Read is executed, Error code 1 (31H, Shinko protocol) or Exception code 2 (02H, MODBUS protocol) will be returned.

If any value **other than 0001H** (Clear key operation change flag) is written, Error code 3 (33H, Shinko protocol) or Exception code 3 (03H, MODBUS protocol) will be returned.

## 7.3 Data

### 7.3.1 Notes about Write/Read Command

- The data (set value, decimal) is converted to a hexadecimal number. Negative numbers are represented in 2's complement.
- When connecting multiple slaves, the address (instrument number) must not be duplicated.
- Do not use undefined Data items. If they are used, negative acknowledgement will be returned or a random value will be written or read, resulting in malfunction.
- MODBUS protocol uses Holding Register addresses. The Holding Register addresses are created as follows. A Shinko command Data item is converted to decimal number, and the offset of 40001 is added. The result is the Holding Register address.  
Using Data item 0001H (SV1) as an example: Data item in the sending message is 0001H, however, MODBUS protocol Holding Register address is 40002 (1 + 40001).

### 7.3.2 Write Command

- Setting range of each item is the same as that of keypad operation.
- When data (set value) has a decimal point, a whole number (hexadecimal) without a decimal point is used.
- Writing via software communication will be possible even in the set value lock status.
- If Lock 3 is selected in [Set value lock], the written data will not be saved in the non-volatile IC memory. Therefore, if the power is turned off, they will return to their value before Lock 3.
- If an alarm type is changed in [Alarm type] (Data items 0023H, 0006H, 0007H, 0008H, 0009H), the alarm value (Data items 000BH, 0012H, 0014H, 0016H, 0018H) will default to 0 (zero). Alarm output status will also be initialized.
- Even if options are not ordered, writing via software communication will be possible. However, their command contents will not function.
- Communication parameters such as Instrument Number, Communication Speed of the slave cannot be written by software communication. They can only be set via the keypad. See p.3.
- When writing a command by Global address [95 (7FH), Shinko protocol] or Broadcast address [(00H) MODBUS protocol], the same command is sent to all the slaves connected. However, the response is not returned.
- Up to 1,000,000 (one million) entries can be stored in non-volatile IC memory.  
If the number of writings exceeds the limit, the data will not be saved. So, do not change the set values frequently via software communication. (If a value written via software communication is the same as the value before the writing, the value will not be written in non-volatile IC memory.)

### 7.3.3 Read Command

- When the data (set value) has a decimal point, a whole number (hexadecimal) without a decimal point is used for a response.

## 7.4 Negative Acknowledgement

The slave will return Error code 1 (31H, Shinko protocol) or Exception code 2 (02H, MODBUS protocol) in the following case:

- When non-existent data item is read or written.

The slave will return Error code 3 (33H, Shinko protocol) or Exception code 3 (03H, MODBUS protocol) in the following case:

- When a value out of the setting range is written.

The slave will return Error code 4 (34H, Shinko protocol) or Exception code 17 (11H, MODBUS protocol) in the following cases:

- When 0001H (AT Perform) is written **at** Data item 0003H or 00E6H (AT Perform/Cancel) during PI control or ON/OFF control action
- While AT is performing, and if 0001H (AT Perform) is written **at** Data item 0003H or 00E6H (AT Perform/Cancel)
- When Write is executed for Manual control MV (00E5H) during automatic control

The slave will return Error code 5 (35H, Shinko protocol) or Exception code 18 (12H, MODBUS protocol) in the following case:

- During setting mode by keypad operation

## 7.5 Notes on Programming Monitoring Software

### 7.5.1 How to Speed up the Scan Time

When monitoring multiple units of the controller, set the program so that the requisite minimum pieces of data such as Data item 0080H or 0100H (PV), Data item 0081H or 0101H (OUT1 MV), Data item 0082H or 0102H (OUT2 MV), Data item 0085H (Status flag), Data item 010DH (Status flag 1), can be read. For other data, set the program so that they can be read only when their set value has changed. This will speed up the scan time.

### 7.5.2 How to Read the Set Value Changes Made by Front Keypad Operation

If any set value is changed by the keypad operation, the controller sets 0085H (Status flag) or 010DH (Status flag 1, 2<sup>15</sup>: Change in key operation) to “1 (Yes)”.

There are 2 methods of reading the set value changes made by front keypad.

#### (1) Reading method 1

- ① On the monitoring software side, check that 0085H (Status flag) or 010DH (Status flag 1, 2<sup>15</sup>: Change in key operation) has been set to “1 (Yes)”, then read all set values.
- ② Clear 0085H (Status flag) or 010DH (Status flag 1, 2<sup>15</sup>: Change in key operation), by writing 0001H (Clear key operation change flag) **at** Data item 0070H or 00FFH (Key operation change flag clearing).  
If 0001H (Clear key operation change flag) is written **at** Data item 0070H or 00FFH (Key operation change flag clearing) during the setting mode of the controller, Error code 5 (35H, Shinko protocol) or Exception Code 18 (12H, MODBUS protocol) will be returned as a negative acknowledgement. And 0085H (Status flag) or 010DH (Status flag 1, 2<sup>15</sup>: Change in key operation) cannot be cleared.  
Set a program so that all set values can be read when a negative acknowledgement is returned.
- ③ Read all set values again after acknowledgement is returned.

#### (2) Reading method 2

- ① On the monitoring software side, check that 0085H (Status flag) or 010DH (Status flag 1, 2<sup>15</sup>: Change in key operation) has been set to “1 (Yes)”, then write 0001H (Clear key operation change flag) **at** Data item 0070H or 00FFH (Key operation change flag clearing).
- ② Set the program depending on the acknowledgement or negative acknowledgement as follows.  
When acknowledgement is returned;  
Consider it as settings completed, and read all set values.  
When Error code 5 (35H, Shinko protocol) or Exception code 18 (12H, MODBUS protocol) is returned as a negative acknowledgement;  
Consider it as still in setting mode, and read the requisite minimum pieces of data such as Data item 0080H or 0100H (PV), 0081H or 0101H (OUT1 MV), 0082H or 0102H (OUT2 MV), 0085H (Status flag), 010DH (Status flag 1), then return to Step ①.

Thus, programs which do not affect the scan time can be created using the methods described above, even if set values on the monitoring software will not be updated until settings are complete.

### 7.5.3 How to Read PID Parameters after AT Finishes

While AT is performing, this controller sets 0085H (Status flag) or 010DH (Status flag 1, 2<sup>11</sup>: During AT) to “1 (During AT)”.

After AT is finished, PID parameters are updated.

On the monitoring software side, check that 0085H (Status flag) or 010DH (Status flag 1, 2<sup>11</sup>: During AT) has been set to “0 (OFF)”, then read parameters such as P, I, D, ARW.

### 7.5.4 Note When Sending All Set Values Simultaneously

- When changing alarm types at Data item 0023H, 0006H, 0007H, 0008H or 0009H (Alarm type), the alarm values will default to 0 (zero).  
First, send the selected alarm type, then send each alarm value.
- When changing input types at Data item 0044H or 0002H (Input type), the set values such as SV1, OUT1 proportional band, Alarm value will be initialized.  
First, send the selected input type, then send other set values.

## 7.6 When Communicating with a PLC

To communicate with a PLC, use the SIF-600, Shinko PLC Interface Unit.

No programming is needed for connection. However, Shinko protocol Multiple pieces of data Read (24H) and Multiple pieces of data Write (54H) are not available.

### PLCs corresponding to the SIF-600, its manufacturer and host link units:

PLC manufacturer	PLC model	Host link unit model
Mitsubishi Electric Corp.	MELSEC Q, QnA series (*)	AJ71UC24, A1SJ71UC24-R2/R4/PRF A1SJ71C24-R2/R4/PRF, QJ71C24
	MELSEC FX series (*)	
Omron Corp.	SYSMAC CJ series	CS1W-SCU21-V1 CJ1W-SCU21, CJ1W-SCU41
Keyence Corp.	KV	KV-L20V
Yokogawa Electric Corp.	FA-M3	F3LC11-2N, F3LC11-1F, F3LC12-1F
Fuji Electric Co., Ltd.	MICREX-SX series	NP1L-RS1, NP1L-RS2, NP1L-RS3, NP1L-RS4

(\*) Models with compatible QR/QW communication commands (MC protocol 1C Format 4).

# 8. SV Digital Transmission

Step SV can be received from the connected Shinko programmable controllers PCA1 or PCB1 (on which 'SV digital transmission' should be selected in [Communication protocol]).

## 8.1 Wiring

When connecting to the PCB1, connect YA (-) to YA (-), YB (+) to YB (+), SG (PCB1) to COM (DCL-33A) respectively.

Up to 31 units of the DCL-33A can be connected.

The following shows a connection example of PCB1 and DCL-33A (Fig. 8.1-1).

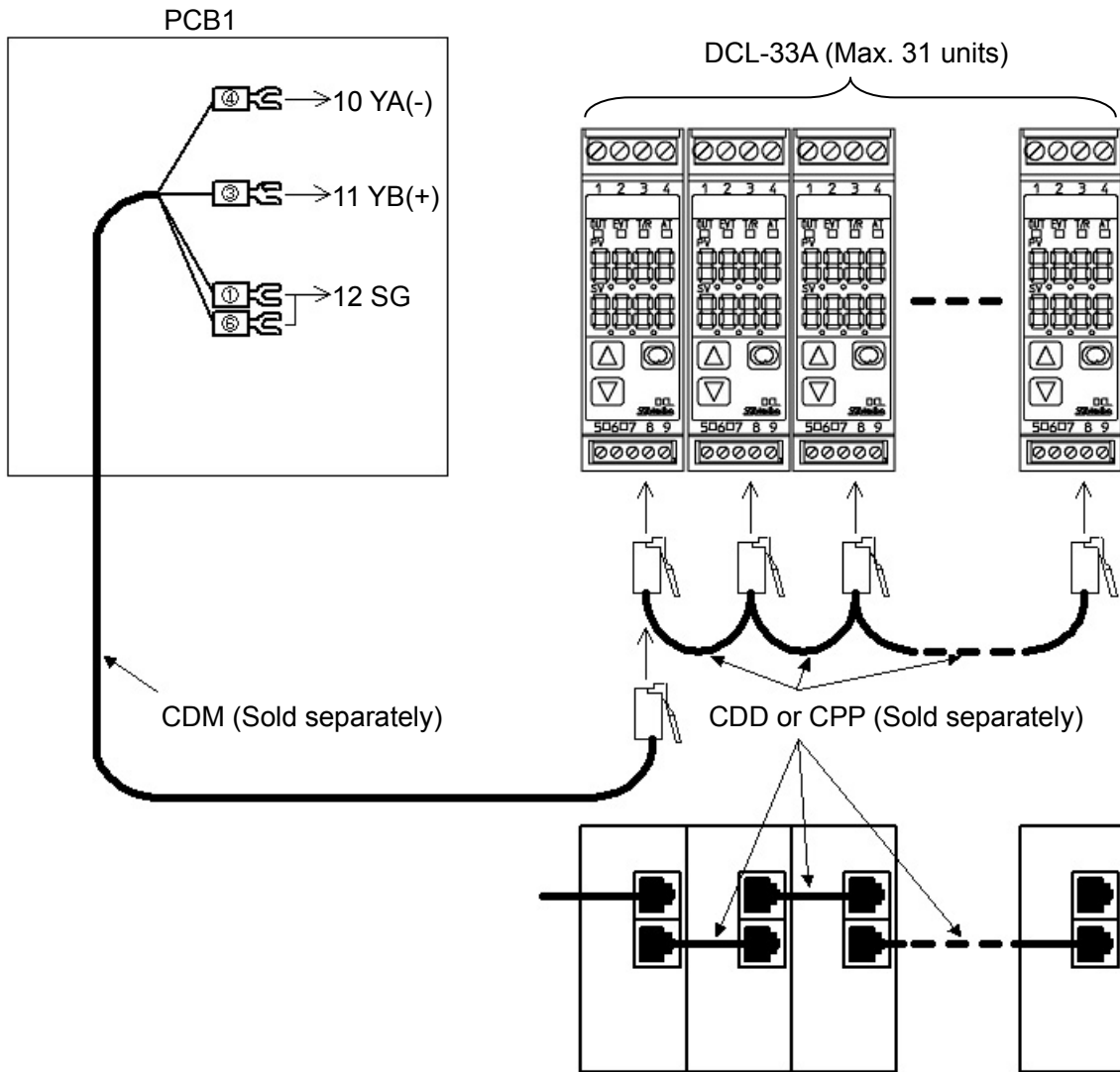

(Fig. 8.1-1)

## 8.2 Setting Method of Controllers

### (1) Setting the PCB1

Set the following. Refer to the Instruction Manual for the PCB1.

- Select "SV digital transmission (Shinko protocol)" in [Communication protocol].
- Select 9600 bps, 19200 bps or 38400 bps in [Communication speed].

### (2) Setting the DCL-33A

Check the following settings. (Refer to the Instruction Manual for the DCL-33A.)

- Shinko protocol has been selected in [Communication protocol].
- Communication speed of the DCL-33A is identical with that of PCB1 (9600 bps, 19200 bps or 38400 bps).

### (3) The SV Digital Transmission starts.

Enter the program values on the PCB1, and press the **RUN** key to perform program control. Step SV of the PCB1 will be transmitted to the DCL-33A.

During Program control STOP (in Standby), 0 (zero) is sent to the DCL-33A.

## 9. Specifications

Cable length: 1.2 km (Max.) Cable resistance: Within 50  $\Omega$  (Terminators are not necessary, but if used, use 120  $\Omega$  minimum on both sides.)

Communication line: EIA RS-485

Communication method: Half-duplex communication

Communication speed: 2400/4800/9600/19200/38400 bps (Selectable by keypad) (Default: 9600 bps)

Synchronization method: Start-stop synchronization

Code form: ASCII, binary

Communication protocol: Shinko protocol/MODBUS ASCII/MODBUS RTU (Selectable by keypad) (Default: Shinko protocol)

Data format:

Communication protocol	Shinko Protocol	MODBUS ASCII	MODBUS RTU
Start bit	1	1	1
Data bit	7	7	8
Parity	Even	Even (No parity, Odd) Selectable	No parity (Even, Odd) Selectable
Stop bit	1	1 (2) Selectable	1 (2) Selectable

Error correction: Command request repeat system

Error detection: Parity check, checksum (Shinko protocol), LRC (MODBUS ASCII), CRC-16 (MODBUS RTU)

## 10. Troubleshooting

Check that power is being supplied to the master and slave that customers use.  
If communication failure still occurs, check the following.

- **Problem: Communication failure**

Check if any of the following have occurred.
Imperfect contact between the communication cable and the connector, or between the communication connector and instrument port
Incorrect wiring of the communication cable and/or connector.
Communication speed of the slave does not match that of the master.
The data bit, parity and stop bit of the master do not correspond to those of the slave.
The instrument number (address) of the slave does not correspond to that of the command.
The instrument numbers (addresses) are duplicated in multiple slaves.
Make sure that the program is appropriate for the transmission timing.

- **Problem: Although communication is occurring, the response is negative acknowledgement.**

Check if any of the following have occurred.
A non-existent command code has been sent.
The Write command data exceeds the setting range of the slave.
The DCL-33A cannot be written when functions such as AT are performing.
The DCL-33A is in front keypad operation setting mode.

For all other malfunctions, please contact our main office or dealers.

**MOD-TRONIC**

[www.mod-tronic.com](http://www.mod-tronic.com) | [sales@mod-tronic.com](mailto:sales@mod-tronic.com) | 1-800-794-5883