

Ranges and Resolution

See table below. Select range and default engineering units.
Consult factory for special engineering units.
Units may be changed to any listed under the same sensor range.
Resolution is fixed and limited to available display digits.

Accuracy

Includes linearity, hysteresis, repeatability
Standard: ±0.25% of full scale ±1 least significant digit
HA option: ±0.1% FS ±1 LSD, see table below for availability

Display

3 readings per second nominal display update rate
4 digit LCD, 0.5" H and 5 character 0.25" H alphanumeric
BL: Red LED backlight on when gauge is on

Power

8-24 VAC 50/60 Hz or 9-32 VDC

AD: Approximately 5 mA

ADBL: Approximately 80 mA

3 ft long, 2-conductor 22 AWG cable

All models are designed for continuous operation

Order optional WMPSK 115V/12 VDC wall mount power supply kit.

Controls and Functions

Front button turns gauge on or off, zeros gauge reference gauges, and cycles through min/max functions
Internal buttons for engineering unit selection, auto shutoff time, min/max setup, calibration. Pass code protected setup & calibration.

Min/Max Functions

Minimum and maximum readings stored 3 times per second
Front button cycles through min display, max display, clear
Configurable for min only, max only, min/max, or none
Configure to clear or retain min/max values at power off

Calibration

Pass code protected calibration
Non-interactive zero, span, and linearity, ±10% of range

Weight

Gauge: 9 ounces (approximately)
Shipping: 1 pound (approximately)

Housing

F16AD: Extruded aluminum case, epoxy powder coated, ABS/polycarbonate bezel (aluminum bezel optional), front and rear gaskets, polycarbonate label

F16ADN: ABS/polycarbonate NEMA 4X case, rear gasket, polycarbonate label

Connection and Material

1/4" NPT male fitting, 316L stainless steel
All wetted parts are 316L stainless steel

Overpressure, Burst, Vacuum

Ranges using 3000 psig sensor: 5000 psig
Ranges using 5000 psig sensor: 7500 psig
All others: 2 X pressure range
3000 psi, 5000 psi, and 4 digit ranges 112.5% full scale out-of-range display: 1--- or 1---.---

4 X sensor burst pressure rating, or 10,000 psi, whichever is less

Vacuum service: ±15 psig, 15 psig, 30 psia, 100 psia, 100 psia, 200 psig sensors.

Under-range display (non-vacuum sensors): -Err

Environmental

Storage temperature: -40 to 203°F (-40 to 95°C)
Operating temperature: -4 to 185°F (-20 to 85°C)
Compensated temperature: 32 to 158°F (0 to 70°C)

- ±0.25% Test Gauge Accuracy
- 316 Stainless Steel Wetted Parts
- Minimum, Maximum, Zero Functions
- Selectable Units
- Low Voltage Powered



F16AD



F16ADN

Sensor Ranges and Engineering Units ± -HA option not available											
3 psig ±	Res	15 psig vac ±	Res	30 psia ±	Res	-15V100psig ±	Res	300 psig	Res		
3PSIG	.001	100KPAVAC	.1	2KGCMA	.001	-15V100PSIG	.1	300PSIG	.1		
6INHGG	.001	0.1MPAVAC	.0001	2ATMA	.001	-30INHG/100PSIG	.1	610INHGG	.1		
85INH20G	.1	1BARVAC	.001	30 psig	Res	-30V200INHGG	.1	4800ZING	1		
50ZING	.01	1KGCMMVAC	.01	30PSIG	.01	-400V2770INH20G	1	700FTH20	.1		
210GCMG	.1	1ATMVAC	.001	60INHGG	.01	-240V1600ZING	1	2000KPAG	1		
150MMHGG	.1	15 psig	Res	850INH20G	1	-760V5200MMHGG	1	2MPAG	.001		
150TORRG	.1	15PSIG	.01	480ZING	.1	-760V5200TORRG	1	20BARG	.01		
200MBARG	.1	30INHGG	.01	2100GCMG	1	-100V700KPAG	1	20KGCMMG	.01		
200CMH20G	.1	400INH20G	.1	1600MMHGG	1	-0.1V0.7MPAG	.001	20ATMG	.01		
2000MMH20G	1	240ZING	.1	1600TORRG	1	-1V7BARG	.01	500 psig	Res		
7FTH20	.001	1000GCMG	1	2000MBARG	1	-1V7KGCMMG	.01	500PSIG	.1		
20KPAG	.01	760MMHGG	.1	2100CMH20G	1	-1V7ATMG	.01	1020INHGG	1		
5 psig		Res	760TORRG	.1	70FTH20	.01	100 psig	Res	1150FTH20	1	
5PSIG	.001	1000MBARG	1	200KPAG	1	100PSIG	.1	3500KPAG	1		
10INHGG	.01	1000CMH20G	1	0.2MPAG	.0001	200INHGG	.1	3.5MPAG	.001		
140INH20G	.1	35FTH20	.01	2BARG	.001	2770INH20G	1	35BARG	.01		
80ZING	.1	100KPAG	.1	2KGCMMG	.001	1600ZING	1	35KGCMMG	.01		
350GCMG	.1	0.1MPAG	.0001	2ATMG	.001	7000GCMG	1	35ATMG	.01		
260MMHGG	.1	1BARG	1	60 psig	Res	5200MMHGG	1	1000 psig	Res		
260TORRG	.1	1KGCMMG	1	60PSIG	.01	5200TORRG	1	1000PSIG	1		
350MBARG	.1	1ATMG	1	120INHGG	.1	7000MBARG	1	2040INHGG	1		
350CMH20G	.1	±15 psig ±	Res	1660INH20G	1	7000CMH20G	1	2300FTH20	1		
3500MMH20G	1	±15PSIG	.01	960ZING	1	230FTH20	.1	7000KPAG	1		
12FTH20	.01	-30INHG/15PSIG	.01	4200GCMG	1	700KPAG	1	7MPAG	.0001		
35KPAG	.01	±30INHGG	.01	3100MMHGG	1	0.7MPAG	.0001	70BARG	.01		
15 psia ±	Res	±400INH20G	1	3100TORRG	1	7BARG	.001	70KGCMMG	.01		
15PSIA	.01	±240ZING	.1	4100MBARG	1	7KGCMMG	.001	70ATMG	.01		
30INHGA	.01	±1000GCMG	1	4200CMH20G	1	7ATMG	.001	2000 psig	Res		
400INH20A	.1	±760MMHGG	1	140FTH20	.1	-15V200 psig ±	Res	2000PSIG	1		
240ZINA	.1	±760TORRG	1	400KPAG	.1	-15V200PSIG	.1	4070INHGG	1		
1000GCMG	1	±1000MBAR	1	0.4MPAG	.0001	-30INHG/200PSIG	.1	4600FTH20	1		
760MMHGA	.1	±1000CMH20G	1	4BARG	.001	-30V400INHGG	.1	14MPAG	.01		
760TORRA	.1	±100KPAG	.1	4KGCMMG	.001	-400V5500INH20G	1	140BARG	.1		
1000MBARA	1	±0.1MPAG	.0001	4ATMG	.001	-240V3200ZING	1	140KGCMMG	.1		
1000CMH20A	1	±1BARG	.001	100 psia ±	Res	-100V1400KPAG	1	140ATMG	.1		
100KPAA	.1	±1KGCMMG	.001	100PSIA	.1	-0.1V1.4MPAG	.001	3000 psig	Res		
0.1MPAA	.0001	±1ATMG	.001	200INHGA	.1	-1V14BARG	.01	3000PSIG	1		
1BARA	.001	30 psia ±	Res	2770INH20A	1	-1V14KGCMMG	.01	6100INHGG	1		
1KGCMA	.001	30PSIA	.01	1600ZINA	1	-1V 14ATMG	.01	6900FTH20	1		
1ATMA	.001	60INHGA	.01	7000GCMG	1	200 psig	Res	20MPAG	.01		
15 psig vac ±	Res	850INH20A	1	5200MMHGA	1	200PSIG	.1	200BARG	.1		
15PSIVAC	.01	480ZINA	.1	5200TORRA	1	400INHGG	.1	200KGCMMG	.1		
30INHGVAC	.01	2100GCMG	1	7000MBARA	1	5500INH20G	1	200ATMG	.1		
400INH20VAC	.1	1600MMHGA	1	7000CMH20A	1	3200ZING	1	5000 psig	Res		
240ZINVAC	.1	1600TORRA	1	700KPAA	.1	480FTH20	.1	5000PSIG	1		
1000GCMVAC	1	2000MBARA	1	0.7MPAA	.0001	1400KPAG	1	35MPAG	.01		
760MMHGVAC	.1	2100CMH20A	1	7BARG	.001	1.4MPAG	.001	350BARG	.1		
760TORRVAC	.1	200KPAA	.1	7KGCMA	.001	14BARG	.01	350KGCMMG	.1		
1000MBARVAC	1	0.2MPAA	.0001	7ATMA	.001	14KGCMMG	.01	340ATMG	.1		
1000CMH20VAC	1	2BARA	.001	14ATMG	.01	14ATMG	.01				

How to Specify	Type
F16AD range - options	Standard housing
F16ADBL range - options	Standard housing, backlight display
F16ADN range - options	NEMA 4X housing
F16ADNBL range - options	NEMA 4X housing, backlight display

Range—see table at left

psi = PSI torr = TORR mbar = MBAR
 inHg = INHG mmH₂O = MMH2O bar = BAR
 oz/in² = ZIN kg/cm² = KGCM cmH₂O = CMH2O
 inH₂O = INH2O g/cm² = GCM atm = ATM
 ftH₂O = FTH2O kPa = KPA
 mmHg = MMHG MPa = MPA

G = gauge reference pressure
 VAC = gauge reference vacuum
 A = absolute reference

If vacuum gauge requires a minus sign, please specify.
 The range code indicates the gauge's default range. Engineering units may be changed to any of those listed under the same sensor range. The listed ranges are rounded off.

Options—add to end of model number	
HA	High accuracy, ±0.1% FS ±1 LSD. Not available with 3 psi, bipolar, absolute, or vacuum sensors, and some 3.5 digit display ranges. See table at left for availability.
PM	Panel mount, 4.1" x 4.1". Not avail. with NEMA models.
MC	Metal front cover. Not available with NEMA models.
CC	Moisture resistant circuit board conformal coating
TP	Top gauge port. Not available with NEMA models.
Accessories—order separately	
WMPSK	Wall mount power supply kit, 115 VAC/12 VDC
RB	Protective rubber boot. Not avail. with NEMA models.
CD	Calibration data; 5 test points and date
NC	NIST traceability documentation, 5 points and date

Example: **F16ADBL100PSIG-HA**
 Low voltage powered, backlight display, 0-100 psig, high accuracy

Dimensions

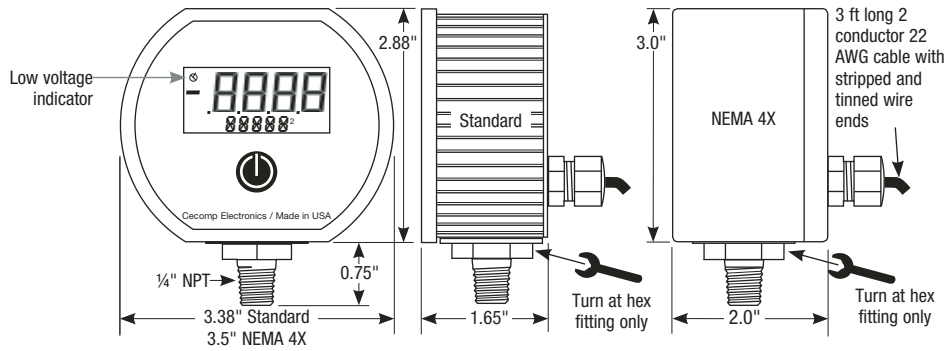

Installation Precautions

- ✓ Read these instructions before using the gauge. Configuration may be easier before installation. Contact the factory for assistance.
- ✓ These products do not contain user-serviceable parts. Contact us for repairs, service, or refurbishment.
- ✓ Gauges must be operated within specified ambient temperature ranges.
- ✓ Outdoor or wash down applications require a NEMA 4X gauge or installation in a NEMA 4X housing.
- ✓ Use a pressure or vacuum range appropriate for the application.
- ✓ Use fittings appropriate for the pressure range of the gauge.
- ✓ Due to the hardness of 316 stainless steel, it is recommended that a thread sealant be used to ensure leak-free operation.
- ✓ For contaminated media use an appropriate screen or filter to keep debris out of gauge port.
- ✓ Remove system pressures before removing or installing gauge.
- ✓ Install or remove gauge using a wrench on the hex fitting only. Do not attempt to turn gauge by forcing the housing.
- ✓ Good design practice dictates that positive displacement liquid pumps include protection devices to prevent sensor damage from pressure spikes, acceleration head, and vacuum extremes.
- ✗ Avoid permanent sensor damage! Do not apply vacuum to non-vacuum gauges or hydraulic vacuum to any gauges.
- ✗ Avoid permanent sensor damage! NEVER insert objects into gauge port or blow out with compressed air.
- ⚠ Gauges are not for oxygen service. Accidental rupture of sensor diaphragm may cause silicone oil inside sensor to react with oxygen.

Types of Gauges

Bipolar ranges read positive pressure and vacuum in the same units, and zero with the gauge port open.

1000 psi and higher sensor are a sealed reference type. They read zero with the gauge port open are internally referenced to 14.7 psi. Functionally similar to gauge reference sensors.

Absolute reference gauges read zero at full vacuum and atmospheric pressure with the gauge port open. With an open gauge port the readings will vary continuously due to the effects of barometric pressure.

Selectable Ranges

Range Codes

The range code is part of the gauge model number and indicates the default range when the gauge is ordered.

Selectable Ranges

Engineering units may be changed to any of those listed in the same sensor range as shown in the range table.

Conversion

Engineering units are calculated from the factory default unit to the newly selected units. The ranges listed under the psi sensor range are rounded off.

Power

The AD series is powered by 8-24 VAC 50/60 Hz or 9-32 VDC.

The type and magnitude of the supply voltage have negligible effects on the gauge calibration as long as it is within the voltage ranges stated above. No polarity needs to be observed when connecting a power supply. An inexpensive unregulated low voltage AC or DC power supply can be used.

After the gauge is installed, route the wires away from heat sources and moving equipment and connect the low-voltage power source to the gauge wires.

Ensure that the gauge supply voltage does not fall below 8 VAC_{RMS} if AC power is used, or 9 VDC if DC power is used. Operation with less than these values may cause erratic or erroneous readings.

When operating multiple gauges from the same power supply, refer to the mA rating in the specifications to ensure adequate power.

Note that standard 24 VAC transformers with small loads often operate at voltages well over the gauge's 24 VAC limit.

Operation

Power-Up

Press and hold the front button for approximately 1 second.

The display is tested, the default full-scale range is indicated, the full-scale range in the selected units are indicated, the display is tested again, then the actual pressure and units are displayed.

Power-Up With Zero

This applies to gauge reference models only. Absolute reference gauges do not use the zero feature since they read atmospheric pressure under normal conditions.

Be sure the gauge port is exposed to normal atmospheric pressure and no pressure is applied. The zeroing function is only activated at each power-up and the stored zero correction is erased when the gauge is shut off.

Press and hold the front button. The display is tested and then 0000 is displayed. The gauge is now zeroed. Release the button and the full-scale range in the selected units are indicated, the display is tested again, then the actual pressure and units are displayed.

Attempting to zero the gauge with pressure greater than approximately 3% of full-scale pressure or vacuum applied will result in an error condition, and the display will alternately indicate Err 0 and the actual measured pressure. The gauge must be powered down to reset the error condition.

Normal Operation

Following the start-up initialization, the display indicates the pressure reading updated approximately 3 times per second. The gauge may be left on continuously or shut off as desired.

If excessive vacuum is applied to a pressure-only gauge, the display will indicate -Err until the vacuum is released.

Applying vacuum to a gauge designed for pressure may damage the pressure sensor. If excessive pressure is applied (112.5% over range), an out-of-range indication of 1 - - - or 1.-.- will be displayed depending on model.

Display Backlighting (BL models only)

Display backlighting is on whenever the gauge is on.

The display backlighting will not be apparent under bright lighting conditions.

Operation—continued

Minimum and Maximum Readings

Gauges are normally configured with minimum and maximum capture functions enabled. One or both can be disabled in the User Configuration mode.

Minimum and maximum readings are continuously stored and updated whenever the gauge is on. The stored readings can be manually cleared if desired. The MAX and MIN memory is also cleared whenever the gauge is off unless configured to save the readings.

Press and hold the button for about 1 second until MAX is displayed alternating with the units. The maximum reading will be continuously updated. The gauge may be left in this mode.

After MAX is displayed, press and hold the button for about 1 second until MIN is displayed alternating with the units. The minimum reading will be continuously updated. The gauge may be left in this mode. If excessive vacuum is applied to a pressure-only gauge while in this mode, the display will indicate -Err until the MAX/MIN readings are cleared.

After MIN is displayed, press and hold the button again for about 1 second until * * * * is displayed. The MAX and MIN memory is not erased and the gauge returns to normal operation with the display indicating the current reading.

Press and continue to hold the button until the display indicates CLR MX/MIN (about 3 seconds total) and then release the button. Both maximum and minimum values are cleared and the gauge returns to the normal mode and displays the current pressure.

Shut-Down

To shut off the gauge manually at any time, press and hold the button until the display indicates OFF (about 5 seconds) and then release.

Function	Button	Prompt (Release Button)
On	Press for 1 second	Display test > default units > selected units <i>FULL SCALE</i> > display test > actual reading
Zero (gauge ref. only)	Press and hold	Display test > 0000 > default units > selected units <i>FULL SCALE</i> > display test > actual reading
Hi reading	Press/hold	<i>MAX</i> > max. reading & units
Lo reading	Press/hold	<i>MIN</i> > min. reading & units
Exit Hi/Lo	Press/hold	* * * * > actual reading
Clear Hi/Lo	Press/hold	<i>MAX</i> > <i>CLR MAX/MIN</i> > actual reading
Clear, off	Press/hold	<i>MAX</i> > <i>CLR MAX/MIN</i> > <i>OFF</i>

Cecomp maintains a constant effort to upgrade and improve its products. Specifications are subject to change without notice. Consult factory for your specific requirements.

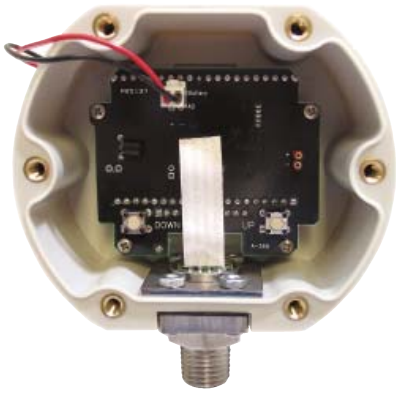
Basic Configuration**Engineering Unit Selection**

Engineering unit selection is done via internal buttons to help prevent accidental or unauthorized changes. The selected engineering unit is stored in non-volatile memory and will be retained even with the gauge off or batteries removed. The available engineering units depend on the sensor range and display resolution.

Compound (inHg/PSIG) gauges must be changed to display single-unit vacuum/pressure readings in the Advanced Configuration mode before different engineering units can be selected.

The default engineering units are mathematically converted to the newly selected engineering unit. When the gauge is powered up, the originally configured range is displayed and then the conversion with the selected engineering unit is displayed.

To change engineering units remove the rear cover to gain access to the two internal buttons located near the lower right and left corners of the circuit board.

With the gauge powered up, press and hold the UP button. Release the button when the engineering units begin to flash.

Use the UP and DOWN buttons to scroll through the list of engineering units available for the pressure range of the sensor.

When the desired units are displayed, press and release the front button to save the selection and return to normal operation.

Note: The gauge will automatically revert to normal operation if no buttons are operated for approximately 15 seconds.

Replace the rear cover taking care not to pinch the power wires between the cover and the case.

Advanced Configuration

User configuration allows requires a pass code for access and allows more features to be configured.

Remove the rear cover to gain access to the buttons located near the lower right and left corners of the circuit board.

With the gauge off, press and hold the UP button. Then press the front button. Release all buttons when the display indicates CFG and the program version then the full-scale range is indicated and the display is tested.

The display then indicates _ _ _ _ with the first underscore blinking, and with CFGPC (configuration pass code) on the character segments.

Note: The gauge will automatically revert to normal operation if no buttons are operated for approximately 15 seconds. To cancel and return to normal operation, press and release the front button without entering any pass code characters.

Pass Code Entry

The factory default is 3510, but this may be changed by the user under the Pass Code Configuration section.

1. Use the UP or DOWN buttons to set the left-most digit to 3.
2. Press and release the front button to move to the next position. The 3 will remain, and the second position will be blinking.
3. Use the UP or DOWN buttons to select 5.
4. Press and release the front button to index to the next position. 35 will remain, and the third position will be blinking.
5. Use the UP or DOWN buttons to select 1.
6. Press and release the front button to index to the next position. 351 will remain, and the fourth position will be blinking.
7. Use the UP or DOWN buttons to select 0.
8. Press and release the front button to proceed with configuration procedures.

If an incorrect pass code is entered, the gauge will return to the start of the pass code entry sequence.

Factory/User Configuration

The upper display section will be blank, and the lower section will display either USER_ or FCTRY.

If USER_ is selected, the user configuration can be modified as described in the following steps.

To select USER_, press and release the DOWN button.

The lower display will indicate USER_.

Press and release the front button to continue.

If FCTRY is selected, the existing user configuration will be replaced by the original factory configuration.

To select FCTRY, press and release the UP button.

The lower display will indicate FCTRY.

Press and release the front button to restore the factory configuration and restart the gauge.

Max/Min Configuration

Use the UP and DOWN buttons to select from the following:

- MX/MN Both highest and lowest values will be captured
 MX/--- Only highest value will be captured
 --/MN Only lowest value will be captured
 --/-- Capture feature is disabled

Press and release the front button to move to the next parameter.

Max/Min Memory

The upper display section will indicate clr.

Use the UP and DOWN buttons to select from the following:

- AUTO Automatically clear max. and min. values when the gauge is powered off
 MAN Manually clear max. and min. values

Press and release the front button to move to the next parameter.

Gauge Type Configuration

This will only appear with 15, 100, or 200 psig ranges that were originally ordered as compound gauges.

Use the UP and DOWN buttons to select from the following:

- /+EU Vacuum is indicated as negative pressure in the selected engineering units
 CMPND Vacuum is negative INHG, pressure is PSIG. This setting will disable engineering unit selection.

Press and release the front button to save the user configuration and restart the gauge.

Replace the rear cover taking care not to pinch the power wires between the cover and the case.

Calibration Preparation

All gauges are factory calibrated using NIST traceable calibration equipment. Calibration is not required before using the gauge. Calibration intervals depend on your quality standards, but annual re-calibration is customary.

Calibration equipment is not required to zero gauge reference ranges. Absolute reference ranges may be zeroed with application of full vacuum.

Span calibration should only be performed using appropriate calibration procedures with calibration standards that are at least four times more accurate than the gauge being calibrated.

The calibration system must be able to generate and measure pressure/vacuum over the full range of the gauge. A vacuum pump able to produce a vacuum of 100 microns (0.1 torr or 100 millitorr) or lower is required for vacuum and absolute gauges.

Connect gauge to a 8-24 VAC 50/60 Hz or 9-32 VDC power supply.

Allow the gauge to equalize to normal room temperature for approximately 20 minutes before calibration.

Remove the rear cover to gain access to the UP and DOWN buttons located near the lower right and left corners of the circuit board.

Continued on next page...

Calibration

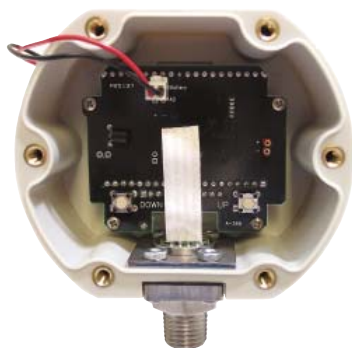

Entering Calibration Mode

With the gauge off, press and hold the DOWN button. Then press the front button. Release all buttons when the display indicates CAL.

The display begins by indicating the full-scale positive pressure rating of the gauge in the engineering units as configured by the factory, and then shows all display.

Before the gauge enters the Calibration Mode, the display initially indicates _____ with the first underscore blinking, and with CALPC (calibration pass code) on the lower display.

Note: The gauge will automatically revert to normal operation if no buttons are operated for approximately 15 seconds. To cancel and return to normal operation, press and release the front button without entering any pass code characters.

Enter the User-Modifiable Pass Code

The factory default is 3510, but this is user changeable.

1. Use the UP or DOWN buttons to set the left-most digit to 3.
2. Press and release the front button to move to the next position. The 3 will remain, and the second position will be blinking.
3. Use the UP or DOWN buttons to select 5.
4. Press and release the front button to index to the next position. 35 will remain, and the third position will be blinking.
5. Use the UP or DOWN buttons to select 1.
6. Press and release the front button to index to the next position. 351 will remain, and the fourth position will be blinking.
7. Use the UP or DOWN buttons to select 0.
8. Press and release the front button to proceed with configuration procedures.

If an incorrect pass code is entered, the gauge will return to the start of the pass code entry sequence.

Calibration Mode

The gauge enters and remains in the calibration mode until restarted manually or power is removed. Features not related to calibration are disabled and compound range models are set for the same engineering units for pressure and for vacuum.

The calibration may be performed in any of the available engineering units as well as percent (PCT). For greatest accuracy, use the UP and DOWN buttons to select engineering units for calibration with highest resolution (highest number of display counts). Press and release the front button when the appropriate engineering units are displayed. Suggested units are listed below.

Sensor	Suggested units for calibration
5 PSI	5.000 PSI
15 PSI	775.7 MMHG (TORR)
30 PSI	61.08 INHG
50 PSI	50.00 PSI
60 PSI	60.00 PSI
100 PSI	7.031 KG/CM2
200 PSI	407.2 INHG
300 PSI	610.8 INHG
500 PSI	500.0 PSI
1000 PSI	70.31 KG/CM2
2000 PSI	4072 INHG
3000 PSI	6108 INHG
5000 PSI	5000 PSI
Any	100.00 PCT (percent)

The display will then indicate the currently applied pressure in the engineering units selected for calibration.

Calibration—continued

UP and DOWN Button Operation

Each time one of the calibration buttons is pressed and released quickly, a small change is made to the digitized pressure signal. It may take more than one of these small changes to result in a single digit change on the display.

To make larger changes, press and hold the appropriate calibration button. After about one second, the display will begin to change continuously. Release the button to stop. Then make fine adjustments by pressing and quickly releasing the calibration buttons as previously described.

Gauge Reference Pressure Gauges

Apply zero pressure by venting the gauge port to atmosphere. The character display will alternate between ZERO and CAL. Adjust for a display indication of zero using the UP and the DOWN buttons.

Apply full-scale pressure. The character display will alternate between +SPAN and CAL. Adjust for a display indication of full-scale pressure using the UP and the DOWN buttons.

Apply 50% full-scale pressure. The character display will alternate between +MID and CAL. Adjust for a display indication equal to 50% of full-scale pressure using the UP and the DOWN buttons.

Gauge Reference Vacuum Gauges

Apply zero pressure by venting the gauge port to atmosphere. The character display will alternate between ZERO and CAL. Adjust for a display indication of zero using the UP and the DOWN buttons.

Apply full-scale vacuum. The character display will alternate between +SPAN and CAL. Adjust for a display indication of full-scale vacuum using the UP and the DOWN buttons.

Apply 50% full-scale vacuum. The character display will alternate between +MID and CAL. Adjust for a display indication equal to 50% of full-scale vacuum using the UP and the DOWN buttons.

Absolute Reference Gauges

Apply full vacuum to the gauge. The character display will alternate between ZERO and CAL. Press the UP and DOWN buttons to obtain a display indication of zero.

Apply full-scale pressure. The character display will alternate between +SPAN and CAL. Press the UP and DOWN buttons to obtain a display indication equal to full-scale pressure.

Apply 50% of full-scale pressure. The lower display will alternate between +MID and CAL. Press the UP and DOWN buttons to obtain an indication equal to 50% of full-scale pressure.

Compound and Bipolar Gauges

In addition to the steps described above for pressure gauges, apply full-scale vacuum. The character display will alternate between -SPAN and CAL. Adjust for a display indication of actual applied vacuum using the UP and the DOWN buttons.

For bipolar and -30.00inHg/+15.00psig compound range models only, apply 50% full-scale vacuum. The character display will alternate between -MID and CAL. Adjust for a display indication equal to 50% of full-scale vacuum using the UP and the DOWN buttons.

Save Calibration

Once the adjustments are complete, press and hold the front button until the display indicates - - - - then release the button to store the calibration parameters in non-volatile memory and restart the gauge.

Verify the pressure indications at 0%, 25%, 50%, 75% and 100% of full scale.

Replace the rear cover taking care not to pinch the wires between the cover and the case.

User-Defined Pass Code Configuration

Remove the rear cover to access the buttons located near the lower right and left corners of the circuit board.

View or change user configuration pass code
With the unit off, press and hold the UP button, then press the front button.

Release all buttons when the display indicates CFG.

View or change user calibration pass code
With the unit off, press and hold the DOWN button, then press the front button.

Release all buttons when the display indicates CAL.

Enter access code 1220

Before the unit enters the view or change pass code mode, the display initially indicates ' _ _ _ _ ' with the first underscore blinking, and with CFGPC or CALPC on the character display.

Note: The gauge will automatically revert to normal operation if no buttons are operated for approximately 15 seconds.

To cancel and return to normal operation, press and release the POWER button without entering any pass code characters.

1. Use the UP and DOWN buttons to set the left-most digit to 1.
2. Press and release the front button to move to the next position. The 1 will remain, and the second position will be blinking.
3. Use the UP and DOWN buttons to select 2.
4. Press and release the front button to index to the next position. 12 will remain, and the third position will be blinking.
5. Use the UP and DOWN buttons to select 2.
6. Press and release the front button to move to the next position. 1 2 2 will remain, and the fourth position will be blinking.
7. Use the UP and DOWN buttons to select 0.
8. Press and release the front button to proceed.

Note: If an incorrect access code was entered, the gauge will return to the start of the access code entry sequence.

Once the access code has been entered correctly, the display will indicate the existing user-defined pass code with CFGPC or CALPC on the character segments.

1. Operate the UP or DOWN button to select the first character of the new pass code.
2. When the correct first character is being displayed, press and release the front button to proceed to the next pass code character.
3. Repeat above until the entire pass code is complete.
4. To exit, press and hold the front button. Release the button when the display indicates ---- to restart the gauge.
5. Replace the rear cover taking care not to pinch the power wires between the cover and the case.