

COMMUNICATION INSTRUCTION MANUAL **JCL-33A (C5)**

No.JCL3CE3 2018.11

This manual contains instructions for the communication functions, operations and notes when operating the JCL-33A.

To prevent accidents arising from the misuse of this controller, please ensure the operator receives this manual.

Warning

Turn the power supply to the instrument off before wiring or checking. Working on or touching the terminal with the power switched on may result in severe injury or death due to electrical shock.

1. System Configuration

1.1 When Using USB Communication Cable CMC-001-1 (Sold Separately)

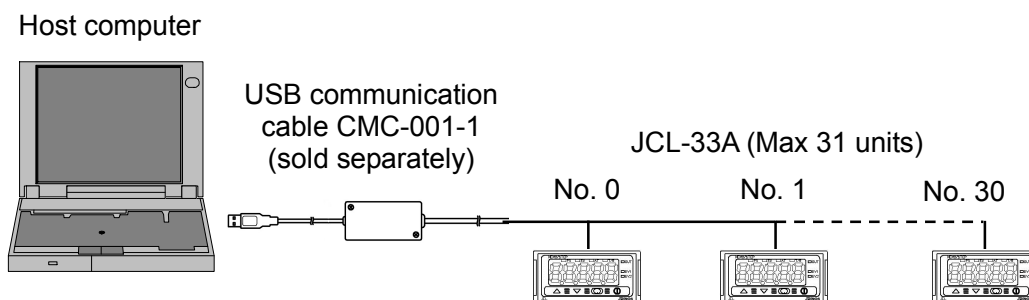

(Fig. 1.1-1)

1.2 When Using Communication Converter IF-400 (Sold Separately)

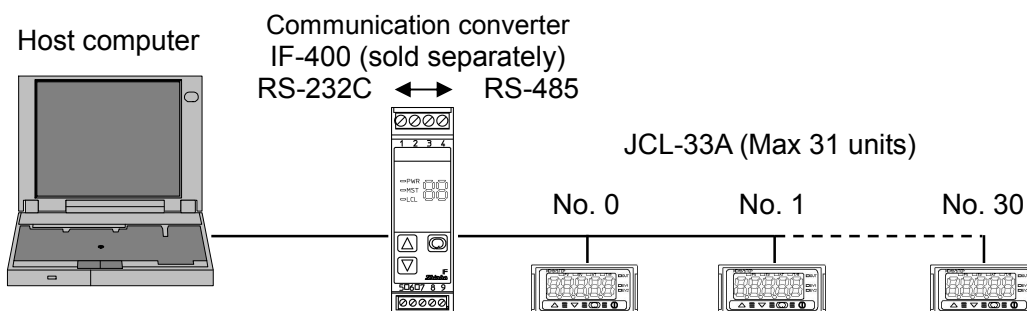

(Fig. 1.2-1)

1.3 System Configuration of SV Digital Transmission

By connecting to Shinko Programmable Controllers [PCA1 or PCB1 (with C5 option)], SV can be received from programmable controllers.

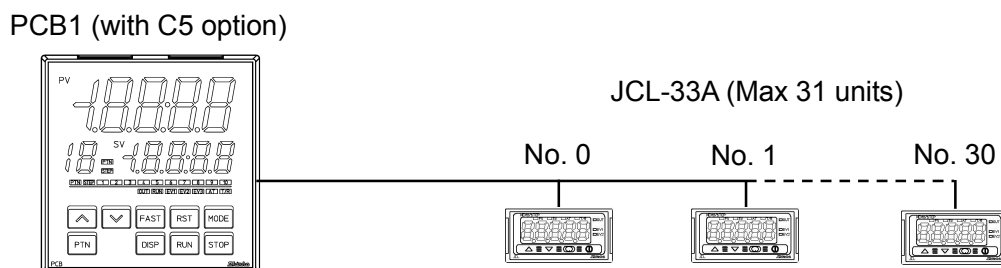

(Fig. 1.3-1)

2. Wiring

2.1 When Using USB Communication Cable CMC-001-1 (sold separately)

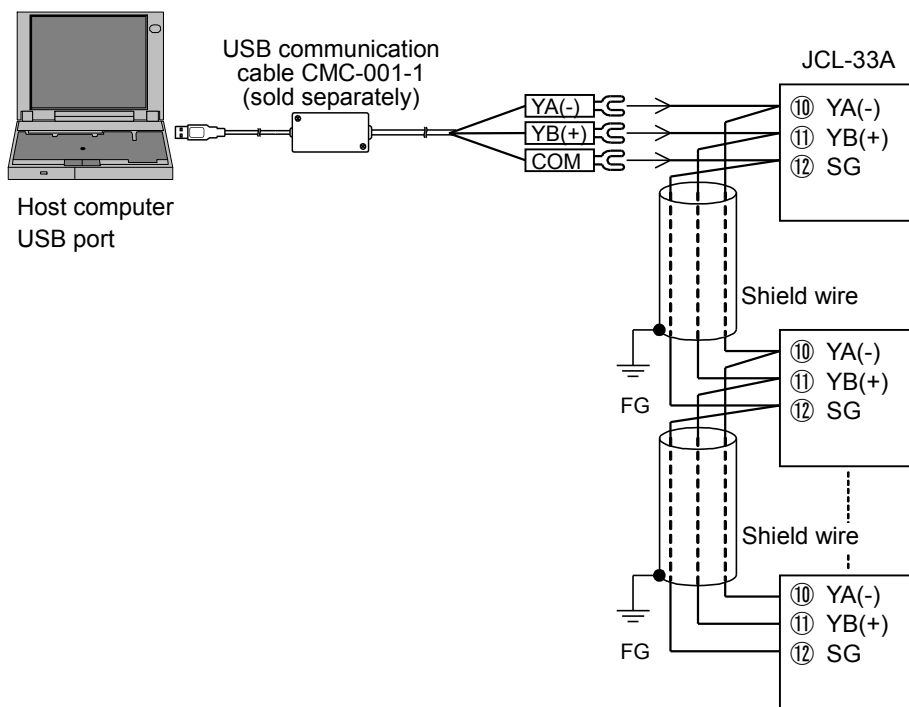

(Fig. 2.1-1)

2.2 When Using Communication Converter IF-400 (Sold Separately)

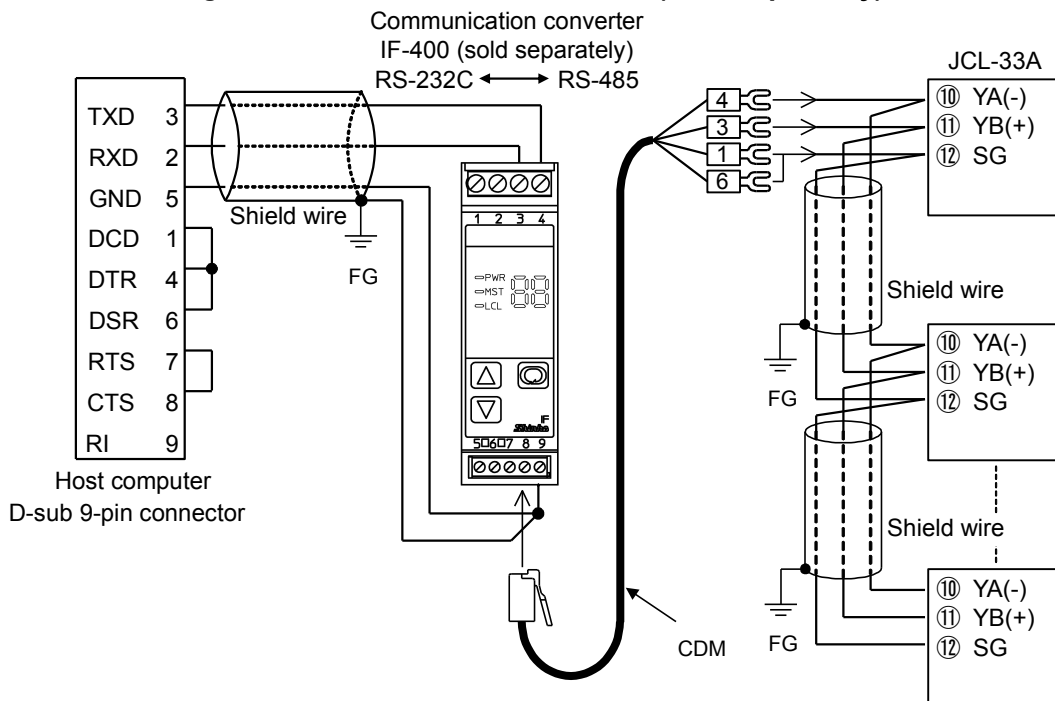

(Fig. 2.2-1)

Shield wire

Connect only one end of the shield to the FG terminal to avoid a ground loop. If both ends of the shield wire are connected to the FG terminal, the circuit will be closed, resulting in a ground loop. This may cause noise.

Be sure to ground the FG terminal.

Recommended cable: OTSC-VB 2PX0.5SQ (made by Onamba Co., Ltd.) or equivalent (Use a twisted pair cable.)

Terminator (Terminal resistor)

Communication converter IF-400 (sold separately) has a built-in terminator.

The terminator is mounted at the end of the wire when connecting multiple peripheral devices to a personal computer. The terminator prevents signal reflection and disturbance.

Do not connect a terminator to the communication line because the JCL-33A has built-in pull-up and pull-down resistors.

3. Setting Communication Parameters

Set communication parameters in Auxiliary function setting mode 1.

To enter Auxiliary function setting mode 1, press the ∇ and \odot keys (in that order) together for approx. 3 seconds in PV/SV Display Mode. 'PV/SV indication' appears.

Press the \odot key 3 times. 'Communication protocol' appears.

Use the Δ or ∇ key for settings (or selections), and register them with the \odot key.

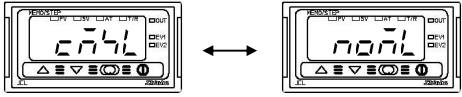
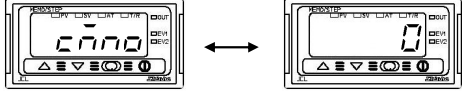
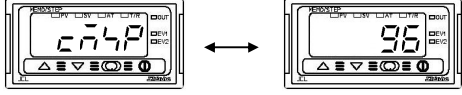
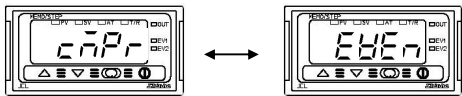
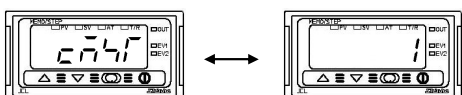
Display	Item, Function, Setting range	Factory Default
	Communication protocol <ul style="list-style-type: none"> • Selects communication protocol. • <i>n0L</i> : Shinko protocol • <i>n0dR</i> : Modbus ASCII mode • <i>n0dr</i> : Modbus RTU mode • <i>b0L</i> : Shinko protocol (Block Read/Write available) • <i>b0dR</i> : Modbus ASCII mode (Block Read/Write available) • <i>b0dr</i> : Modbus RTU mode (Block Read/Write available) 	Shinko protocol
	Instrument number <ul style="list-style-type: none"> • Sets the instrument number. The instrument numbers should be set one by one when multiple instruments are connected in Serial communication, otherwise communication is impossible. • Available only when the C5 option is equipped. • Setting range: 0 to 95 	0
	Communication speed <ul style="list-style-type: none"> • Selects a communication speed equal to that of the host computer. • $\square 24$: 2400 bps • $\square 48$: 4800 bps • $\square 96$: 9600 bps • $\square 192$: 19200 bps • $\square 384$: 38400 bps 	9600 bps
	Parity <ul style="list-style-type: none"> • Selects the parity equal to that of the host computer. • Not available if Shinko protocol or Shinko protocol (Block Read/Write available) is selected. • <i>n0nE</i> : No parity • <i>EVEN</i> : Even • <i>odd</i> : Odd 	Even
	Stop bit <ul style="list-style-type: none"> • Selects the stop bit equal to that of the host computer. • Not available if Shinko protocol or Shinko protocol (Block Read/Write available) is selected. • $\square 1$: 1 bit • $\square 2$: 2 bits 	1 bit

Press the \odot key.

The unit reverts to PV/SV display Mode.

Now, settings are complete.

4. Communication Procedure

Communication starts with command transmission from the host computer (hereafter Master) and ends with the response of the JCL-33A (hereafter Slave).

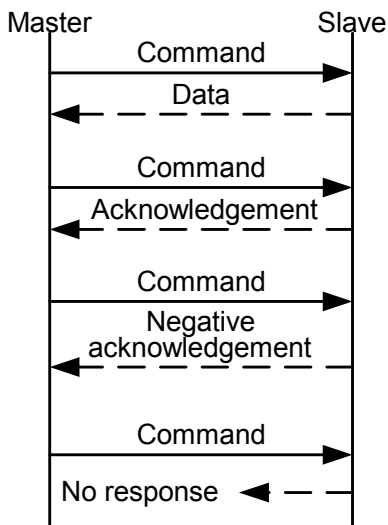

(Fig. 4-1)

• Response with data

When the master sends the Read command, the slave responds with the corresponding set value or current status.

• Acknowledgement

When the master sends the Write command, the slave responds by sending the acknowledgement after the processing is terminated.

• Negative acknowledgement

When the master sends a non-existent command or value out of the setting range, the slave returns a negative acknowledgement.

• No response

The slave will not respond to the master in the following cases:

- Global address (Shinko protocol) is set.
- Broadcast address (Modbus protocol) is set.
- Communication error (framing error, parity error)
- Checksum error (Shinko protocol), LRC discrepancy (Modbus ASCII mode), CRC-16 discrepancy (Modbus RTU mode)

Communication Timing of the RS-485 (C5 option)

Master Side (Take note while programming)

When the master starts transmission through the RS-485 communication line, the master is arranged so as to provide an idle status (mark status) transmission period of 1 or more characters before sending the command to ensure synchronization on the receiving side.

Set the program so that the master can disconnect the transmitter from the communication line within a 1 character transmission period after sending the command in preparation for reception of the response from the slave.

To avoid collision of transmissions between the master and the slave, send the next command after carefully checking that the master has received the response.

If a response to the command is not returned due to communication errors, set the Retry Processing to send the command again. (It is recommended to execute Retry twice or more.)

Slave Side

When the slave starts transmission through the RS-485 communication line, the slave is arranged so as to provide an idle status (mark status) of 1 character transmission period or more before sending the response to ensure synchronization on the receiving side.

The slave is arranged so as to disconnect the transmitter from the communication line within a 1 character transmission period after sending the response.

5. Shinko Protocol

5.1 Transmission Mode

Shinko protocol is composed of ASCII.

Hexadecimal (0 to 9, A to F), which is divided into high order (4-bit) and low order (4-bit) out of 8-bit binary data in command is transmitted as ASCII characters.

Data format Start bit: 1 bit
 Data bit: 7 bits
 Parity: Even
 Stop bit: 1 bit

Error detection: Checksum

5.2 Command Configuration

All commands are composed of ASCII.

The data (set value, decimal number) is represented by a hexadecimal number.

The negative numbers are represented by 2's complement.

Numerals written below the command represent number of characters.

(1) Write command

• Write a single piece of data

Header (02H)	Address	Sub address (20H)	Command type (50H)	Data item	Data	Checksum	Delimiter (03H)
1	1	1	1	4	4	2	1

• Write multiple pieces of data

Header (02H)	Address	Sub address (20H)	Command type (54H)	Data item	Data	Checksum	Delimiter (03H)
1	1	1	1	4	4 x n	2	1

n: Amount of data

(2) Read command

• Read a single piece of data

Header (02H)	Address	Sub address (20H)	Command type (20H)	Data item	Checksum	Delimiter (03H)
1	1	1	1	4	2	1

• Read multiple pieces of data

Header (02H)	Address	Sub address (20H)	Command type (24H)	Data item	Amount of read data n	Checksum	Delimiter (03H)
1	1	1	1	4	4	2	1

(3) Response with data

• Response to 'Read a single piece of data'

Header (06H)	Address	Sub address (20H)	Command type (20H)	Data item	Data	Checksum	Delimiter (03H)
1	1	1	1	4	4	2	1

• Response to 'Read multiple pieces of data'

Header (06H)	Address	Sub address (20H)	Command type (24H)	Data item	Data	Checksum	Delimiter (03H)
1	1	1	1	4	4 x n	2	1

n: Amount of data

(4) Acknowledgement

Header (06H)	Address	Checksum	Delimiter (03H)
1	1	2	1

(5) Negative acknowledgement

Header (15H)	Address	Error code	Checksum	Delimiter (03H)
1	1	1	2	1

Header: Control code to represent the beginning of the command or the response.
 ASCII is used.
 Write command, Read command: STX (02H) fixed
 Response with data, Acknowledgement: ACK (06H) fixed
 Negative acknowledgement: NAK (15H) fixed

Instrument number (Address): Numbers by which the master discerns each slave.
 Instrument number 0 to 94 and Global address 95.
 ASCII (20H to 7FH) is used by adding 20H to instrument numbers 0 to 95 (00H to 5FH).
 95 (7FH) is called Global address, which is used when the same command is sent to all the slaves connected. However, the response is not returned.

Sub address: 20H fixed

Command type: Codes for Write command and Read command.

Command Type	Contents	Description
20H	Read (A single piece of data)	Reads a single piece of data.
24H	Read (Multiple pieces of data)	Reads consecutive multiple pieces of data. (Amount of data: Max. 100)
50H	Write (A single piece of data)	Writes a single piece of data.
54H	Write (Multiple pieces of data)	Writes consecutive multiple pieces of data. (Amount of data: Max. 100)

Notes about Read/Write multiple pieces of data

When reading or writing multiple pieces of data, as it takes time until slave sends response data, the master determines no response based on the timeout period below after sending a command.

Timeout period calculation: 6 ms x Amount of data

Data item: Classification of the command object.
 Composed of 4-digit hexadecimal numbers, using ASCII.
 Refer to Section '7. Communication Command Table' (pp.21 - 29).

Data: The contents of data (set values) differ depending on the Write command.
 Composed of 4-digit hexadecimal numbers, using ASCII.
 Refer to Section '7. Communication Command Table' (pp. 21 - 29).

Checksum: 2-character data to detect communication errors.
 Refer to Section '5.3 Checksum Calculation' (p.8).

Delimiter: Control code to represent the end of command.
 ASCII code ETX (03H) fixed

Error code: Represents an error type using ASCII.

- 1 (31H)... Non-existent command
- 2 (32H)... Not used
- 3 (33H)... Setting outside the setting range
- 4 (34H)... Status unable to be written (e.g. AT is performing.)
- 5 (35H)... During setting mode by keypad operation

5.3 Checksum Calculation

Checksum is used to detect receiving errors in the command or data.

Set the program for the master side as well to calculate the checksum of the response data from the slaves so that communication errors can be checked.

The ASCII code (hexadecimal) corresponding to the characters which range from the address to that before the checksum is converted to binary notation, and the total value is calculated.

The lower one byte of the total value is converted to 2's complement, and then to hexadecimal numbers, that is, ASCII code for the checksum.

- 1's complement: Reverse each binary bit. 0 will become 1 and vice versa.
- 2's complement: Add 1 to 1's complement.

[Example of checksum calculation]

Write SV1 to 600°C (0258H). See (Fig. 5.3-1).

Address (instrument number): 0 (20H)

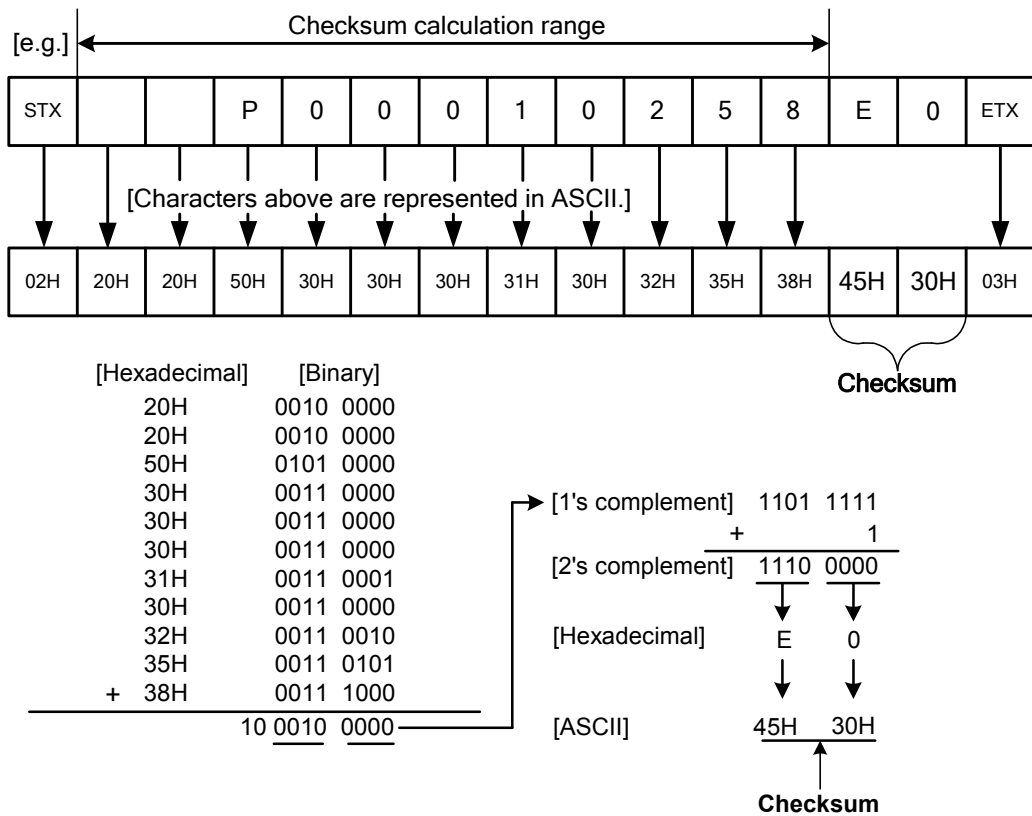

(Fig. 5.3-1)

5.4 Command Example

Numerals written below the command represent number of characters.

(1) Read [Address 1, PV]

- Read command from the master

Header (02H)	Address (21H)	Sub address (20H)	Command type (20H)	Data item [0080H] (30H 30H 38H 30H)	Checksum (44H 37H)	Delimiter (03H)
1	1	1	1	4	2	1

- A response from the slave in normal status [When PV=25°C (0019H)]

Header (06H)	Address (21H)	Sub address (20H)	Command type (20H)	Data item [0080H] (30H 30H 38H 30H)	Data [0019H] (30H 30H 31H 39H)	Checksum (30H 44H)	Delimiter (03H)
1	1	1	1	4	4	2	1

(2) Read [Address 1, SV1]

- Read command from the master

Header (02H)	Address (21H)	Sub address (20H)	Command type (20H)	Data item [0001H] (30H 30H 30H 31H)	Checksum (44H 45H)	Delimiter (03H)
1	1	1	1	4	2	1

- A response from the slave in normal status [When SV1=600°C (0258H)]

Header (06H)	Address (21H)	Sub address (20H)	Command type (20H)	Data item [0001H] (30H 30H 30H 31H)	Data [0258H] (30H 32H 35H 38H)	Checksum (30H 46H)	Delimiter (03H)
1	1	1	1	4	4	2	1

(3) Write [Address 1, SV1]

- Write command from the master [When writing SV1 to 600°C (0258H)]

Header (02H)	Address (21H)	Sub address (20H)	Command type (50H)	Data item [0001H] (30H 30H 30H 31H)	Data [0258H] (30H 32H 35H 38H)	Checksum (44H 46H)	Delimiter (03H)
1	1	1	1	4	4	2	1

- A response from the slave in normal status

Header (06H)	Address (21H)	Checksum (44H 46H)	Delimiter (03H)
1	1	2	1

(4) Read [Address 1, 25 commands from SV1]

- Read command from the master

Header (02H)	Address (21H)	Sub address (20H)	Command type (24H)	Data item [0001H] (30H 30H 30H 31H)	Amount of read data 25 [0019H] (30H 30H 31H 39H)	Checksum (31H 30H)	Delimiter (03H)
1	1	1	1	4	4	2	1

- A response from the slave in normal status

Header (06H)	Address (21H)	Sub address (20H)	Command type (24H)	Data item [0001H] (30H 30H 30H 31H)
1	1	1	1	4

	Data [00000000055A...0000] (30H 30H 30H 30H 30H 30H 30H 30H 30H 30H 35H 35H 41H ... 30H 30H 30H 30H)	Checksum (43H 38H)	Delimiter (03H)
	100 (4 x 25)	2	1

Response data becomes as follows.

	Data Item	Data	Data (Converted to Hexadecimal)
0001H	SV1	0	0000H
0002H	Input type	K [-200 to 1370°C]	0000H
0003H	Scaling high limit	1370	055AH
0004H	Scaling low limit	-200	FF38H
0005H	Decimal point place	No decimal point	0000H
0006H	Alarm 1 type	No alarm action	0000H
0007H	Alarm 2 type	No alarm action	0000H
0008H	Reserved	0	0000H
0009H	Reserved	0	0000H
000AH	SV1/Step 1 SV	0	0000H
000BH	Step 2 SV	0	0000H
000CH	Step 3 SV	0	0000H
000DH	Step 4 SV	0	0000H
000EH	Step 5 SV	0	0000H
000FH	Step 6 SV	0	0000H
0010H	Step 7 SV	0	0000H
0011H	Step 8 SV	0	0000H
0012H	Step 9 SV	0	0000H
0013H	Step 1 time	0	0000H
0014H	Step 2 time	0	0000H
0015H	Step 3 time	0	0000H
0016H	Step 4 time	0	0000H
0017H	Step 5 time	0	0000H
0018H	Step 6 time	0	0000H
0019H	Step 7 time	0	0000H

(5) Write [Address 1, 25 commands from SV1]

(e.g.) The data (25 commands from SV1) is shown below.

	Data Item	Data	Data (Converted to Hexadecimal)
0001H	SV1	2000	07D0H
0002H	Input type	K [-199.9 to 400.0°C]	0001H
0003H	Scaling high limit	4000	0FA0H
0004H	Scaling low limit	0	0000H
0005H	Decimal point place	1 digit after decimal point	0001H
0006H	Alarm 1 type	High limit alarm	0001H
0007H	Alarm 2 type	Low limit alarm	0002H
0008H	Reserved	0	0000H
0009H	Reserved	0	0000H
000AH	SV1/Step 1 SV	2000	07D0H
000BH	Step 2 SV	2000	07D0H
000CH	Step 3 SV	3000	0BB8H
000DH	Step 4 SV	3000	0BB8H
000EH	Step 5 SV	0	0000H
000FH	Step 6 SV	0	0000H
0010H	Step 7 SV	0	0000H
0011H	Step 8 SV	0	0000H
0012H	Step 9 SV	0	0000H
0013H	Step 1 time	60 minutes	003CH
0014H	Step 2 time	120 minutes	0078H
0015H	Step 3 time	30 minutes	001EH
0016H	Step 4 time	60 minutes	003CH
0017H	Step 5 time	120 minutes	0078H
0018H	Step 6 time	0	0000H
0019H	Step 7 time	0	0000H

- Write command from the master (When writing the above data)

Header (02H)	Address (21H)	Sub address (20H)	Command type (54H)	Data item [0001H] (30H 30H 30H 31H)
1	1	1	1	4

	Data [07D000010FA0...0000] (30H 37H 44H 30H 30H 30H 30H 31H 30H 46H 41H 30H...30H 30H 30H 30H)	Checksum (42H 35H)	Delimiter (03H)
	100 (4 x 25)	2	1

- Response from the slave in normal status

Header (06H)	Address (21H)	Checksum (44H 46H)	Delimiter (03H)
1	1	2	1

6. Modbus Protocol

6.1 Transmission Mode

There are 2 transmission modes (ASCII and RTU) in Modbus protocol.

6.1.1 ASCII Mode

Hexadecimal (0 to 9, A to F), which is divided into high order (4-bit) and low order (4-bit) out of 8-bit binary data in command is transmitted as ASCII characters.

Data format Start bit: 1 bit
 Data bit: 7 bits (Selectable)
 Parity: Even (No parity, Odd) (Selectable)
 Stop bit: 1 bit (2 bits) (Selectable)
 Error detection : LRC (Longitudinal Redundancy Check)

6.1.2 RTU Mode

8-bit binary data in command is transmitted as it is.

Data format Start bit: 1 bit
 Data bit: 8 bits
 Parity: No parity (Even, Odd) (Selectable)
 Stop bit: 1 bit (2 bits) (Selectable)
 Error detection: CRC-16 (Cyclic Redundancy Check)

6.2 Data Communication Interval

6.2.1 ASCII Mode

No communication interval limit between characters

6.2.2 RTU Mode

1.5 character transmission times or less
 (Communication speed 2400, 4800, 9600, 19200 bps: 1.5 character transmission times,
 Communication speed 38400 bps: 750 μ s)
 To transmit continuously, an interval between characters which consist of one message, must be within 1.5 character transmission times.
 If an interval lasts longer than 1.5 character transmission times, the JCL-33A assumes that transmission from the master is finished, which results in a communication error, and will not return a response.

6.3 Message Configuration

6.3.1 ASCII Mode

ASCII mode message is configured to start by Header [: (colon) (3AH)] and end by Delimiter [CR (carriage return) (0DH) + LF (Line feed) (0AH)].

Data section: Max. 2 x 252 characters

Header (:)	Slave address	Function code	Data	Error check LRC	Delimiter (CR)	Delimiter (LF)
------------	---------------	---------------	------	-----------------	----------------	----------------

6.3.2 RTU Mode

RTU mode is configured to start after idle time is processed for more than 3.5 character transmission times, and end after idle time is processed for more than 3.5 character transmission times.

(Communication speed 2400, 4800, 9600, 19200 bps: 3.5 character transmission times,
 Communication speed 38400 bps: 1.75 ms)

Data section: Max. 252 bytes

3.5 idle characters	Slave address	Function code	Data	Error check CRC-16	3.5 idle characters
---------------------	---------------	---------------	------	--------------------	---------------------

(1) Slave Address

Slave address is an individual instrument number on the slave side, and is set within the range 0 to 95 (00H to 5FH). The master identifies slaves by the slave address of the requested message. The slave informs the master which slave is responding to the master by placing its own address in the response message.

Slave address 00H (Broadcast address) can identify all the slaves connected. However, slaves do not respond.

(2) Function Code

The function code is the command code for the slave to undertake one of the following actions.

(Table 6.3-1)

Type	Function Code	Sub-Function Code	Contents
Data access	03 (03H)		Reads a single or multiple piece(s) of data from slave(s).
	06 (06H)		Writes a single piece of data to slave(s).
	16 (10H)		Writes multiple pieces of data to slave(s).

The function code is used to discern whether the response is normal (acknowledgement) or if any error (negative acknowledgement) has occurred when the slave returns the response message to the master.

When acknowledgement is returned, the slave simply returns the original function code.

When negative acknowledgement is returned, the MSB of the original function code is set as 1 for the response.

For example, if the master sends request message setting 13H to the function code by mistake, slave returns 93H by setting the MSB to 1, because the former is an illegal function.

For negative acknowledgement, the exception codes below (Table 6.3-2) are set to the data of the response message, and returned to the master in order to inform it of what kind of error has occurred.

(Table 6.3-2)

Exception Code	Contents
1 (01H)	Illegal function (Non-existent function)
2 (02H)	Illegal data address (Non-existent data address)
3 (03H)	Illegal data value (Value out of the setting range)
17 (11H)	Shinko protocol error code 4 (Status unable to be written. (e.g.) AT is performing.)
18 (12H)	Shinko protocol error code 5 (During setting mode by keypad operation)

(3) Data

Data differs depending on the function code.

A request message from the master is composed of a data item, amount of data and setting data.

A response message from the slave is composed of the byte count, data and exception codes in negative acknowledgements, corresponding to the request message.

The effective range of data is -32768 to 32767 (8000H to 7FFFH).

Refer to Section "7. Communication Command Table" (pp.21 - 29).

(4) Error Check

ASCII Mode

After calculating LRC (Longitudinal Redundancy Check) from the slave address to the end of data, the calculated 8-bit data is converted to two ASCII characters, and are appended to the end of message.

How to Calculate LRC

- ① Create a message in RTU mode.
- ② Add all the values from the slave address to the end of data. This is assumed as X.
- ③ Make a complement for X (bit reverse). This is assumed as X.
- ④ Add a value of 1 to X. This is assumed as X.
- ⑤ Set X as an LRC to the end of the message.
- ⑥ Convert the whole message to ASCII characters.

RTU Mode

After calculating CRC-16 (Cyclic Redundancy Check) from the slave address to the end of the data, the calculated 16-bit data is appended to the end of message in sequence from low order to high order.

How to calculate CRC-16

In the CRC-16 system, the information is divided by the polynomial series. The remainder is added to the end of the information and transmitted. The generation of a polynomial series is as follows.

(Generation of polynomial series: $X^{16} + X^{15} + X^2 + 1$)

- ① Initialize the CRC-16 data (assumed as X) (FFFFH).
- ② Calculate exclusive OR (XOR) with the 1st data and X. This is assumed as X.
- ③ Shift X one bit to the right. This is assumed as X.
- ④ When a carry is generated as a result of the shift, XOR is calculated by X of ③ and the fixed value (A001H). This is assumed as X. If a carry is not generated, go to step ⑤.
- ⑤ Repeat steps ③ and ④ until shifting 8 times.
- ⑥ XOR is calculated with the next data and X. This is assumed as X.
- ⑦ Repeat steps ③ to ⑤.
- ⑧ Repeat steps ③ to ⑤ up to the final data.
- ⑨ Set X as CRC-16 to the end of message in sequence from low order to high order.

6.4 Message Example

6.4.1 ASCII Mode

Numerals written below the message represent the number of characters.

(1) Read [Slave address 1, PV (0100H)]

- A request message from the master

Header	Slave address	Function code	Data item [0100H]	Amount of data [0001H]	Error check LRC	Delimiter CR+LF
(3AH)	(30H 31H)	(30H 33H)	(30H 31H 30H 30H)	(30H 30H 30H 31H)	(46H 41H)	(0DH 0AH)
1	2	2	4	4	2	2

- Response message from the slave in normal status [When PV=600°C (0258H)]

Header	Slave address	Function code	Response byte count [02H]	Data [0258H]	Error check LRC	Delimiter CR+LF
(3AH)	(30H 31H)	(30H 33H)	(30H 32H)	(30H 32H 35H 38H)	(41H 30H)	(0DH 0AH)
1	2	2	2	4	2	2

(2) Write [Slave address 1, SV1 (0001H)]

- A request message from the master [When writing SV1 to 600°C (0258H)]

Header	Slave address	Function code	Data item [0001H]	Data [0258H]	Error check LRC	Delimiter CR+LF
(3AH)	(30H 31H)	(30H 36H)	(30H 30H 30H 31H)	(30H 32H 35H 38H)	(39H 45H)	(0DH 0AH)
1	2	2	4	4	2	2

- Response message from the slave in normal status

Header	Slave address	Function code	Data item [0001H]	Data [0258H]	Error check LRC	Delimiter CR+LF
(3AH)	(30H 31H)	(30H 36H)	(30H 30H 30H 31H)	(30H 32H 35H 38H)	(39H 45H)	(0DH 0AH)
1	2	2	4	4	2	2

- Response message from the slave in exception (error) status (When a value out of the setting range is written)

The function code MSB is set to 1 for the response message in exception (error) status [86H (38H 36H)]. The exception code 03H (30H 33H: Value out of the setting range) is returned (error).

Header	Slave address	Function code	Exception code [03H]	Error check LRC	Delimiter CR+LF
(3AH)	(30H 31H)	(38H 36H)	(30H 33H)	(37H 36H)	(0DH 0AH)
1	2	2	2	2	2

(3) Read [Slave address 1, SV1 (0001H)]

- A request message from the master

Header (3AH)	Slave address (30H 31H)	Function code (30H 33H)	Data item [0001H] (30H 30H 30H 31H)	Amount of data [0001H] (30H 30H 30H 31H)	Error check LRC (46H 41H)	Delimiter CR+LF (0DH 0AH)
1	2	2	4	4	2	2

- Response message from the slave in normal status [When SV1=600°C (0258H)]

Header (3AH)	Slave address (30H 31H)	Function code (30H 33H)	Response byte count [02H] (30H 32H)	Data [0258H] (30H 32H 35H 38H)	Error check LRC (41H 30H)	Delimiter CR+LF (0DH 0AH)
1	2	2	2	4	2	2

- Response message from the slave in exception (error) status (When data item is incorrect)
The function code MSB is set to 1 for the response message in exception (error) status [83H (38H 33H)].

The exception code 02H (30H 32H: Non-existent data address) is returned (error).

Header (3AH)	Slave address (30H 31H)	Function code (38H 33H)	Exception code [02H] (30H 32H)	Error check LRC (37H 41H)	Delimiter CR+LF (0DH 0AH)
1	2	2	2	2	2

(4) Read [Slave address 1, 25 commands from SV1]

- A request message from the master

Header (3AH)	Slave address (30H 31H)	Function code (30H 33H)	Data item [0001H] (30H 30H 30H 31H)	Amount of data [0019H] (30H 30H 31H 39H)	Error check LRC (45H 32H)	Delimiter CR+LF (0DH 0AH)
1	2	2	4	4	2	2

- Response message from the slave in normal status

Header (3AH)	Slave address (30H 31H)	Function code (30H 33H)	Response byte count [32H] (33H 32H)
1	2	2	2

Data [00000000055A...0000] (30H 30H 30H 30H 30H 30H 30H 30H 35H 35H 41H...30H 30H 30H 30H)			Error check LRC (33H 34H)	Delimiter CR+LF (0DH 0AH)
100 (4 x 25)			2	2

Response data section is shown below.

	Data Item	Data	Data (Converted to Hexadecimal)
0001H	SV1	0	0000H
0002H	Input type	K [-200 to 1370°C]	0000H
0003H	Scaling high limit	1370	055AH
0004H	Scaling low limit	-200	FF38H
0005H	Decimal point place	No decimal point	0000H
0006H	Alarm 1 type	No alarm action	0000H
0007H	Alarm 2 type	No alarm action	0000H
0008H	Reserved	0	0000H
0009H	Reserved	0	0000H
000AH	SV1/Step 1 SV	0	0000H
000BH	Step 2 SV	0	0000H
000CH	Step 3 SV	0	0000H
000DH	Step 4 SV	0	0000H
000EH	Step 5 SV	0	0000H
000FH	Step 6 SV	0	0000H
0010H	Step 7 SV	0	0000H
0011H	Step 8 SV	0	0000H
0012H	Step 9 SV	0	0000H
0013H	Step 1 time	0	0000H
0014H	Step 2 time	0	0000H
0015H	Step 3 time	0	0000H
0016H	Step 4 time	0	0000H
0017H	Step 5 time	0	0000H
0018H	Step 6 time	0	0000H
0019H	Step 7 time	0	0000H

(5) Write (Slave address 1, 25 commands from SV1)

The data (25 commands from SV1) is shown below as an example.

Amount of data: 25 (0019H)

Byte count: 50 (32H)

Data: Converted to hexadecimal as follows.

	Data Item	Data	Data (Converted to Hexadecimal)
0001H	SV1	2000	07D0H
0002H	Input type	K [-199.9 to 400.0°C]	0001H
0003H	Scaling high limit	4000	0FA0H
0004H	Scaling low limit	0	0000H
0005H	Decimal point place	1 digit after decimal point	0001H
0006H	Alarm 1 type	High limit alarm	0001H
0007H	Alarm 2 type	Low limit alarm	0002H
0008H	Reserved	0	0000H
0009H	Reserved	0	0000H
000AH	SV1/Step 1 SV	2000	07D0H
000BH	Step 2 SV	2000	07D0H
000CH	Step 3 SV	3000	0BB8H
000DH	Step 4 SV	3000	0BB8H
000EH	Step 5 SV	0	0000H
000FH	Step 6 SV	0	0000H
0010H	Step 7 SV	0	0000H
0011H	Step 8 SV	0	0000H
0012H	Step 9 SV	0	0000H
0013H	Step 1 time	60 minutes	003CH
0014H	Step 2 time	120 minutes	0078H
0015H	Step 3 time	30 minutes	001EH
0016H	Step 4 time	60 minutes	003CH
0017H	Step 5 time	120 minutes	0078H
0018H	Step 6 time	0	0000H
0019H	Step 7 time	0	0000H

- A request message from the master (when writing the above data)

Header (3AH)	Slave address (30H 31H)	Function code (31H 30H)	Data item [0001H] (30H 30H 30H 31H)	Amount of data [0019H] (30H 30H 31H 39H)	Byte count [32H] (33H 32H)	
1	2	2	4	4	2	

Data [07D00001 ••• 0000 (30H 37H 44H 30H 30H 30H 30H 31H ••• 30H 30H 30H 30H)]			Error check LRC (35H 45H)	Delimiter CR+LF (0DH 0AH)
100 (4 x 25)			2	2

- Response message from the slave in normal status

Header (3AH)	Slave address (30H 31H)	Function code (31H 30H)	Data item [0001H] (30H 30H 30H 31H)	Amount of data [0019H] (30H 30H 31H 39H)	Error check LRC (44H 35H)	Delimiter CR+LF (0DH 0AH)
1	2	2	4	4	2	2

6.4.2 RTU Mode

Numerals written below the message represent number of characters.

(1) Read [Slave address 1, PV (0100H)]

- A request message from the master

3.5 idle characters	Slave address (01H)	Function code (03H)	Data item (0100H)	Amount of data (0001H)	Error check CRC-16 (85F6H)	3.5 idle characters
	1	1	2	2	2	

- Response message from the slave in normal status [When PV is 600°C (0258H)]

3.5 idle characters	Slave address (01H)	Function code (03H)	Response byte count (02H)	Data (0258H)	Error check CRC-16 (B8DEH)	3.5 idle characters
	1	1	1	2	2	

(2) Write [Slave address 1, SV1 (0001H)]

- A request message from the master [When 600°C (0258H) is written to SV1]

3.5 idle characters	Slave address (01H)	Function code (06H)	Data item (0001H)	Data (0258H)	Error check CRC-16 (D890H)	3.5 idle characters
	1	1	2	2	2	

- Response message from the slave in normal status

3.5 idle characters	Slave address (01H)	Function code (06H)	Data item (0001H)	Data (0258H)	Error check CRC-16 (D890H)	3.5 idle characters
	1	1	2	2	2	

- Response message from the slave in exception (error) status (When a value out of the setting range is set)
The function code MSB is set to 1 for the response message in exception (error) status, and 86H is returned.

The Exception code 03H (Value out of the setting range) is returned (error).

3.5 idle characters	Slave address (01H)	Function code (86H)	Exception code (03H)	Error check CRC-16 (0261H)	3.5 idle characters
	1	1	1	2	

(3) Read [Slave address 1, SV1 (0001H)]

- A request message from the master

3.5 idle characters	Slave address (01H)	Function code (03H)	Data item (0001H)	Data (0001H)	Error check CRC-16 (D5CAH)	3.5 idle characters
	1	1	2	2	2	

- Response message from the slave in normal status [When SV1 is 600°C (0258H)]

3.5 idle characters	Slave address (01H)	Function code (03H)	Response byte count (02H)	Data (0258H)	Error check CRC-16 (B8DEH)	3.5 idle characters
	1	1	1	2	2	

- Response message from the slave in exception (error) status (When data item is incorrect)
The function code MSB is set to 1 for the response message in exception (error) status, and 83H is returned. The Exception code 02H (Non-existent data address) is returned (error).

3.5 idle characters	Slave address (01H)	Function code (83H)	Exception code (02H)	Error check CRC-16 (C0F1H)	3.5 idle characters
	1	1	1	2	

(4) Read [Slave address 1, 25 commands from SV1]

- A request message from the master

3.5 idle characters	Slave address (01H)	Function code (03H)	Data item (0001H)	Amount of data (0019H)	Error check CRC-16 (D5C0H)	3.5 idle characters
	1	1	2	2	2	

- Response message from the slave in normal status

3.5 idle characters	Slave address (01H)	Function code (03H)	Response byte count (32H)	Data (00000000055A...0000H)	Error check CRC-16 (60D9H)	3.5 idle characters
	1	1	1	50 (2 x 25)	2	

Response data section is shown below.

	Data Item	Data	Data (Converted to Hexadecimal)
0001H	SV1	0	0000H
0002H	Input type	K [-200 to 1370°C]	0000H
0003H	Scaling high limit	1370	055AH
0004H	Scaling low limit	-200	FF38H
0005H	Decimal point place	No decimal point	0000H
0006H	Alarm 1 type	No alarm action	0000H
0007H	Alarm 2 type	No alarm action	0000H
0008H	Reserved	0	0000H
0009H	Reserved	0	0000H
000AH	SV1/Step 1 SV	0	0000H
000BH	Step 2 SV	0	0000H
000CH	Step 3 SV	0	0000H
000DH	Step 4 SV	0	0000H
000EH	Step 5 SV	0	0000H
000FH	Step 6 SV	0	0000H
0010H	Step 7 SV	0	0000H
0011H	Step 8 SV	0	0000H
0012H	Step 9 SV	0	0000H
0013H	Step 1 time	0	0000H
0014H	Step 2 time	0	0000H
0015H	Step 3 time	0	0000H
0016H	Step 4 time	0	0000H
0017H	Step 5 time	0	0000H
0018H	Step 6 time	0	0000H
0019H	Step 7 time	0	0000H

(5) Write (Slave address 1, 25 commands from SV1)

The data (25 commands from SV1) is shown below as an example.

Amount of data: 25 (0019H)

Byte count: 50 (32H)

Data: Converted to hexadecimal as follows.

	Data Item	Data	Data (Converted to Hexadecimal)
0001H	SV1	2000	07D0H
0002H	Input type	K [-199.9 to 400.0°C]	0001H
0003H	Scaling high limit	4000	0FA0H
0004H	Scaling low limit	0	0000H
0005H	Decimal point place	1 digit after decimal point	0001H
0006H	Alarm 1 type	High limit alarm	0001H
0007H	Alarm 2 type	Low limit alarm	0002H
0008H	Reserved	0	0000H
0009H	Reserved	0	0000H
000AH	SV1/Step 1 SV	2000	07D0H
000BH	Step 2 SV	2000	07D0H
000CH	Step 3 SV	3000	0BB8H
000DH	Step 4 SV	3000	0BB8H
000EH	Step 5 SV	0	0000H
000FH	Step 6 SV	0	0000H
0010H	Step 7 SV	0	0000H
0011H	Step 8 SV	0	0000H
0012H	Step 9 SV	0	0000H
0013H	Step 1 time	60 minutes	003CH
0014H	Step 2 time	120 minutes	0078H
0015H	Step 3 time	30 minutes	001EH
0016H	Step 4 time	60 minutes	003CH
0017H	Step 5 time	120 minutes	0078H
0018H	Step 6 time	0	0000H
0019H	Step 7 time	0	0000H

- A request message from the master (When writing the above data)

3.5 idle characters	Slave address (01H)	Function code (10H)	Data item (0001H)	Amount of data (0019H)	Byte count (32H)
	1	1	2	2	1

Data (07D000010FA0 ••• 0000H)	Error check CRC-16 (269AH)	3.5 idle characters
50 (2 x 25)	2	

- Response message from the slave in normal status

3.5 idle characters	Slave address (01H)	Function code (10H)	Data item (0001H)	Amount of data (0019H)	Error check CRC-16 (5003H)	3.5 idle characters
	1	1	2	2	2	

7. Communication Command Table

7.1 Shinko Protocol, Modbus ASCII Mode, Modbus RTU Mode Commands

7.1.1 A Single Piece of Data Read/Write Command

Shinko Command Type	Modbus Function Code	Data Item		Data
20H/50H	03H/06H	0001H	SV1	Set value
20H/50H	03H/06H	0003H	AT Perform/Cancel	0000H: AT Cancel 0001H: AT Perform
20H/50H	03H/06H	0004H	OUT1 proportional band	Set value
20H/50H	03H/06H	0005H	OUT2 proportional band	Set value
20H/50H	03H/06H	0006H	Integral time	Set value
20H/50H	03H/06H	0007H	Derivative time	Set value
20H/50H	03H/06H	0008H	OUT1 proportional cycle	Set value
20H/50H	03H/06H	0009H	OUT2 proportional cycle	Set value
20H/50H	03H/06H	000AH	Manual reset	Set value
20H/50H	03H/06H	000BH	A1 value	Set value
20H/50H	03H/06H	000CH	A2 value	Set value
20H/50H	03H/06H	0012H	Set value lock	0000H: Unlock 0001H: Lock 1 0002H: Lock 2 0003H: Lock 3
20H/50H	03H/06H	0015H	Sensor correction	Set value
20H/50H	03H/06H	0016H	Overlap/Dead band	Set value
20H/50H	03H/06H	0018H	Scaling high limit	Set value
20H/50H	03H/06H	0019H	Scaling low limit	Set value
20H/50H	03H/06H	001AH	Decimal point place	0000H: No decimal point 0001H: 1 digit after decimal point 0002H: 2 digits after decimal point 0003H: 3 digits after decimal point
20H/50H	03H/06H	001BH	PV filter time constant	Set value
20H/50H	03H/06H	001CH	OUT1 high limit	Set value
20H/50H	03H/06H	001DH	OUT1 low limit	Set value
20H/50H	03H/06H	001EH	OUT1 ON/OFF hysteresis	Set value
20H/50H	03H/06H	0022H	OUT2 ON/OFF hysteresis	Set value
20H/50H	03H/06H	0023H	A1 type	0000H: No alarm action 0001H: High limit alarm 0002H: Low limit alarm 0003H: High/Low limits alarm 0004H: High/Low limit range alarm 0005H: Process high alarm 0006H: Process low alarm 0007H: High limit with standby alarm 0008H: Low limit with standby alarm 0009H: High/Low limits with standby alarm 000AH: Timer function 000BH: Pattern end output
20H/50H	03H/06H	0024H	A2 type	Same as those of A1 type
20H/50H	03H/06H	0025H	A1 hysteresis	Set value
20H/50H	03H/06H	0026H	A2 hysteresis	Set value
20H/50H	03H/06H	0029H	A1 delay time	Set value
20H/50H	03H/06H	002AH	A2 delay time	Set value
20H/50H	03H/06H	0037H	ON/OFF (RUN/STOP)	0000H: ON (STOP) 0001H: OFF (RUN)

Shinko Command Type	Modbus Function Code	Data Item		Data
20H/50H	03H/06H	0042H	Alarm HOLD function	0000H: Alarm Not Holding 0001H: Alarm Holding
20H/50H	03H/06H	0044H	Input type	0000H: K [-200 to 1370°C] 0001H: K [-199.9 to 400.0°C] 0002H: J [-200 to 1000°C] 0003H: R [0 to 1760°C] 0004H: S [0 to 1760°C] 0005H: B [0 to 1820°C] 0006H: E [-200 to 800°C] 0007H: T [-199.9 to 400.0°C] 0008H: N [-200 to 1300°C] 0009H: PL-II [0 to 1390°C] 000AH: C(W/Re5-26) [0 to 2315°C] 000BH: Pt100 [-199.9 to 850.0°C] 000CH: JPt100 [-199.9 to 500.0°C] 000DH: Pt100 [-200 to 850°C] 000EH: JPt100 [-200 to 500°C] 000FH: K [-320 to 2500°F] 0010H: K [-199.9 to 750.0°F] 0011H: J [-320 to 1800°F] 0012H: R [0 to 3200°F] 0013H: S [0 to 3200°F] 0014H: B [0 to 3300°F] 0015H: E [-320 to 1500°F] 0016H: T [-199.9 to 750.0°F] 0017H: N [-320 to 2300°F] 0018H: PL-II [0 to 2500°F] 0019H: C(W/Re5-26) [0 to 4200°F] 001AH: Pt100 [-199.9 to 999.9°F] 001BH: JPt100 [-199.9 to 900.0°F] 001CH: Pt100 [-300 to 1500°F] 001DH: JPt100 [-300 to 900°F] 001EH: 4 to 20 mA DC[-1999 to 9999] 001FH: 0 to 20 mA DC[-1999 to 9999] 0020H: 0 to 1 V DC [-1999 to 9999] 0021H: 0 to 5 V DC [-1999 to 9999] 0022H: 1 to 5 V DC [-1999 to 9999] 0023H: 0 to 10 V DC [-1999 to 9999]
20H/50H	03H/06H	0045H	Direct/Reverse action	0000H: Reverse (Heating) 0001H: Direct (Cooling)
20H/50H	03H/06H	0047H	AT bias	Set value
20H/50H	03H/06H	0048H	ARW	Set value
20H/50H	03H/06H	006FH	Key lock	0000H: Key Enabled 0001H: Key Locked
20H/50H	03H/06H	1110H	Step 1 SV (*)	Set value
20H/50H	03H/06H	1111H	Step 1 time	Set value
20H/50H	03H/06H	1120H	Step 2 SV	Set value
20H/50H	03H/06H	1121H	Step 2 time	Set value
20H/50H	03H/06H	1130H	Step 3 SV	Set value
20H/50H	03H/06H	1131H	Step 3 time	Set value
20H/50H	03H/06H	1140H	Step 4 SV	Set value
20H/50H	03H/06H	1141H	Step 4 time	Set value
20H/50H	03H/06H	1150H	Step 5 SV	Set value
20H/50H	03H/06H	1151H	Step 5 time	Set value
20H/50H	03H/06H	1160H	Step 6 SV	Set value

(*) Step 1 SV (1110H) is the same as SV1 (0001H).

Shinko Command Type	Modbus Function Code	Data Item		Data
20H/50H	03H/06H	1161H	Step 6 time	Set value
20H/50H	03H/06H	1170H	Step 7 SV	Set value
20H/50H	03H/06H	1171H	Step 7 time	Set value
20H/50H	03H/06H	1180H	Step 8 SV	Set value
20H/50H	03H/06H	1181H	Step 8 time	Set value
20H/50H	03H/06H	1190H	Step 9 SV	Set value
20H/50H	03H/06H	1191H	Step 9 time	Set value

7.1.2 A Single Piece of Data Write Command

Shinko Command Type	Modbus Function Code	Data Item		Data
50H	06H	0070H	Key operation change flag clearing	0000H: No action 0001H: Clear key operation change flag

7.1.3 A Single Piece of Data Read Command

Shinko Command Type	Modbus Function Code	Data Item		Data
20H	03H	0080H	PV	PV
20H	03H	0081H	OUT1 MV	Current OUT1 MV
20H	03H	0082H	OUT2 MV	Current OUT2 MV
20H	03H	0083H	Current SV	Current SV
20H	03H	0084H	Running step remaining time	Remaining time
20H	03H	0085H	Status flag	0000 0000 0000 0000 2^{15} to 2^0 2^0 digit: OUT1 0: OFF 1: ON (For current output, Not fixed) 2^1 digit: OUT2 0: OFF 1: ON 2^2 digit: A1 output 0: OFF 1: ON 2^3 digit: A2 output 0: OFF 1: ON 2^4 to 2^7 digits: Not used (Always 0) 2^8 digit: Overscale 0: OFF 1: ON 2^9 digit: Underscale 0: OFF 1: ON 2^{10} digit: ON (STOP) / OFF (RUN) 0: ON (STOP) 1: OFF (RUN) 2^{11} digit: During AT 0: OFF 1: During AT 2^{12} digit: OUT/OFF key function 0: Control output ON/OFF 1: Program control 2^{13} digit: Controller/Converter 0: Controller 1: Converter 2^{14} digit: Not used (Always 0) 2^{15} digit: Change in key operation 0: No 1: Yes
20H	03H	0086H	Running step	Running step

7.2 Shinko Protocol (Block Read/Write), Modbus ASCII Mode (Block Read/Write), Modbus RTU Mode (Block Read/Write) Commands

7.2.1 A Single/Multiple Piece(s) of Data Read/Write Command

Shinko Command Type	Modbus Function Code	Data Item		Data
20H/24H/50H/54H	03H/06H/10H	0001H	SV1	Set value
20H/24H/50H/54H	03H/06H/10H	0002H	Input type	0000H: K [-200 to 1370°C] 0001H: K [-199.9 to 400.0°C] 0002H: J [-200 to 1000°C] 0003H: R [0 to 1760°C] 0004H: S [0 to 1760°C] 0005H: B [0 to 1820°C] 0006H: E [-200 to 800°C] 0007H: T [-199.9 to 400.0°C] 0008H: N [-200 to 1300°C] 0009H: PL-II [0 to 1390°C] 000AH: C(W/Re5-26) [0 to 2315°C] 000BH: Pt100 [-199.9 to 850.0°C] 000CH: JPt100 [-199.9 to 500.0°C] 000DH: Pt100 [-200 to 850°C] 000EH: JPt100 [-200 to 500°C] 000FH: K [-320 to 2500°F] 0010H: K [-199.9 to 750.0°F] 0011H: J [-320 to 1800°F] 0012H: R [0 to 3200°F] 0013H: S [0 to 3200°F] 0014H: B [0 to 3300°F] 0015H: E [-320 to 1500°F] 0016H: T [-199.9 to 750.0°F] 0017H: N [-320 to 2300°F] 0018H: PL-II [0 to 2500°F] 0019H: C(W/Re5-26) [0 to 4200°F] 001AH: Pt100 [-199.9 to 999.9°F] 001BH: JPt100 [-199.9 to 900.0°F] 001CH: Pt100 [-300 to 1500°F] 001DH: JPt100 [-300 to 900°F] 001EH: 4 to 20 mA DC [-1999 to 9999] 001FH: 0 to 20 mA DC [-1999 to 9999] 0020H: 0 to 1 V DC [-1999 to 9999] 0021H: 0 to 5 V DC [-1999 to 9999] 0022H: 1 to 5 V DC [-1999 to 9999] 0023H: 0 to 10 V DC [-1999 to 9999]
20H/24H/50H/54H	03H/06H/10H	0003H	Scaling high limit	Set value
20H/24H/50H/54H	03H/06H/10H	0004H	Scaling low limit	Set value
20H/24H/50H/54H	03H/06H/10H	0005H	Decimal point place	0000H: No decimal point 0001H: 1 digit after decimal point 0002H: 2 digits after decimal point 0003H: 3 digits after decimal point

Shinko Command Type	Modbus Function Code	Data Item		Data
20H/24H/50H/54H	03H/06H/10H	0006H	A1 type	0000H: No alarm action 0001H: High limit alarm 0002H: Low limit alarm 0003H: High/Low limits alarm 0004H: High/Low limit range alarm 0005H: Process high alarm 0006H: Process low alarm 0007H: High limit with standby alarm 0008H: Low limit with standby alarm 0009H: High/Low limits with standby alarm 000AH: Timer function 000BH: Pattern end output
20H/24H/50H/54H	03H/06H/10H	0007H	A2 type	Same as those of A1 type
20H/24H/50H/54H	03H/06H/10H	0008H	Reserved (*1)	
20H/24H/50H/54H	03H/06H/10H	0009H	Reserved (*1)	
20H/24H/50H/54H	03H/06H/10H	000AH	Step 1 SV (*2)	Set value
20H/24H/50H/54H	03H/06H/10H	000BH	Step 2 SV	Set value
20H/24H/50H/54H	03H/06H/10H	000CH	Step 3 SV	Set value
20H/24H/50H/54H	03H/06H/10H	000DH	Step 4 SV	Set value
20H/24H/50H/54H	03H/06H/10H	000EH	Step 5 SV	Set value
20H/24H/50H/54H	03H/06H/10H	000FH	Step 6 SV	Set value
20H/24H/50H/54H	03H/06H/10H	0010H	Step 7 SV	Set value
20H/24H/50H/54H	03H/06H/10H	0011H	Step 8 SV	Set value
20H/24H/50H/54H	03H/06H/10H	0012H	Step 9 SV	Set value
20H/24H/50H/54H	03H/06H/10H	0013H	Step 1 time	Set value
20H/24H/50H/54H	03H/06H/10H	0014H	Step 2 time	Set value
20H/24H/50H/54H	03H/06H/10H	0015H	Step 3 time	Set value
20H/24H/50H/54H	03H/06H/10H	0016H	Step 4 time	Set value
20H/24H/50H/54H	03H/06H/10H	0017H	Step 5 time	Set value
20H/24H/50H/54H	03H/06H/10H	0018H	Step 6 time	Set value
20H/24H/50H/54H	03H/06H/10H	0019H	Step 7 time	Set value

(*1) For 'Reserved' items, if a single/multiple piece(s) of data is/are read, acknowledgement will be returned (but data is 0).

If a single/multiple piece(s) of data is/are written, data will be discarded, and acknowledgement will be returned.

(*2) Step 1 SV (000AH) is the same as SV1 (0001H).

Shinko Command Type	Modbus Function Code	Data Item		Data
20H/24H/50H/54H	03H/06H/10H	001AH	Step 8 time	Set value
20H/24H/50H/54H	03H/06H/10H	001BH	Step 9 time	Set value
20H/24H/50H/54H	03H/06H/10H	001CH	A1 value	Set value
20H/24H/50H/54H	03H/06H/10H	001DH	A2 value	Set value
20H/24H/50H/54H	03H/06H/10H	001EH	Reserved (*1)	
20H/24H/50H/54H	03H/06H/10H	001FH	Reserved (*1)	
20H/24H/50H/54H	03H/06H/10H	0020H	A1 hysteresis	Set value
20H/24H/50H/54H	03H/06H/10H	0021H	A2 hysteresis	Set value
20H/24H/50H/54H	03H/06H/10H	0022H	Reserved (*1)	
20H/24H/50H/54H	03H/06H/10H	0023H	Reserved (*1)	
20H/24H/50H/54H	03H/06H/10H	0024H	A1 delay time	Set value
20H/24H/50H/54H	03H/06H/10H	0025H	A2 delay time	Set value
20H/24H/50H/54H	03H/06H/10H	0026H	Reserved (*1)	
20H/24H/50H/54H	03H/06H/10H	0027H	Reserved (*1)	
20H/24H/50H/54H	03H/06H/10H	0028H	OUT1 proportional band	Set value
20H/24H/50H/54H	03H/06H/10H	0029H	Integral time	Set value
20H/24H/50H/54H	03H/06H/10H	002AH	Derivative time	Set value
20H/24H/50H/54H	03H/06H/10H	002BH	ARW	Set value
20H/24H/50H/54H	03H/06H/10H	002CH	Manual reset	Set value
20H/24H/50H/54H	03H/06H/10H	002DH	OUT1 proportional cycle	Set value
20H/24H/50H/54H	03H/06H/10H	002EH	OUT1 ON/OFF hysteresis	Set value
20H/24H/50H/54H	03H/06H/10H	002FH	OUT1 high limit	Set value
20H/24H/50H/54H	03H/06H/10H	0030H	OUT1 low limit	Set value
20H/24H/50H/54H	03H/06H/10H	0031H	OUT2 proportional band	Set value
20H/24H/50H/54H	03H/06H/10H	0032H	OUT2 proportional cycle	Set value
20H/24H/50H/54H	03H/06H/10H	0033H	OUT2 ON/OFF hysteresis	Set value
20H/24H/50H/54H	03H/06H/10H	0034H	Reserved (*1)	
20H/24H/50H/54H	03H/06H/10H	0035H	Reserved (*1)	
20H/24H/50H/54H	03H/06H/10H	0036H	Overlap/Dead band	Set value
20H/24H/50H/54H	03H/06H/10H	0037H	Reserved (*1)	
20H/24H/50H/54H	03H/06H/10H	0038H	Direct/Reverse action	0000H: Reverse (Heating) 0001H: Direct (Cooling)
20H/24H/50H/54H	03H/06H/10H	0039H	Set value lock	0000H: Unlock 0001H: Lock 1 0002H: Lock 2 0003H: Lock 3
20H/24H/50H/54H	03H/06H/10H	003AH	Sensor correction	Set value
20H/24H/50H/54H	03H/06H/10H	003BH	PV filter time constant	Set value
20H/24H/50H/54H	03H/06H/10H	003CH	AT bias	Set value

(*1) For 'Reserved' items, if a single/multiple piece(s) of data is/are read, acknowledgement will be returned (but data is 0).

If a single/multiple piece(s) of data is/are written, data will be discarded, and acknowledgement will be returned.

Shinko Command Type	Modbus Function Code	Data Item		Data
20H/24H/50H/54H	03H/06H/10H	003DH	SVTC bias	Set value
20H/24H/50H/54H	03H/06H/10H	003EH	Timer delay time	Set value
		003FH	Not used (*3)	
		↓	↓	
		00CFH	Not used (*3)	
20H/24H/50H/54H	03H/06H/10H	00D0H	PV/SV indication	0000H: PV indication 0001H: SV indication
20H/24H/50H/54H	03H/06H/10H	00D1H	Output status when input errors occur	0000H: OUT1: Outputs OFF (4 mA) or OUT1 low limit value. OUT2: OFF 0001H: OUT1: Outputs a value between OFF (4mA) and ON (20mA), or a value between OUT1 low limit value and OUT1 high limit value depending on deviation. OUT2: ON
20H/24H/50H/54H	03H/06H/10H	00D2H	EV1 output	0000H: A1 output 0001H: A2 output 0002H: Common to A1 and A2 output
20H/24H/50H/54H	03H/06H/10H	00D3H	EV2 output	Same as those of EV1 output
20H/24H/50H/54H	03H/06H/10H	00D4H	Alarm HOLD function	0000H: Alarm Not Holding 0001H: Alarm Holding
		00D5H	Not used (*3)	
		↓	↓	
		00DFH	Not used (*3)	
20H/50H	03H/06H	00E0H	OUT/OFF key function	0000H: Control output ON/OFF 0001H: Program control
20H/50H	03H/06H	00E1H	ON/OFF (RUN/STOP)	0000H: ON (STOP) 0001H: OFF (RUN)
20H/50H	03H/06H	00E2H	AT Perform/Cancel	0000H: AT Cancel 0001H: AT Perform
20H/50H	03H/06H	00E3H	Controller/Converter function	0000H: Controller 0001H: Converter
20H/50H	03H/06H	00E4H	DI input function	0000H: SV1/SV2 external selection 0001H: ON/OFF (RUN/STOP) external selection 0002H: Timer
20H/50H	03H/06H	00E5H	Step time unit	0000H: Hours:Minutes 0001H: Minutes:Seconds
20H/50H	03H/06H	00E6H	Delay action type	0000H: ON delay 0001H: OFF delay 0002H: ON/OFF delay
20H/50H	03H/06H	00E7H	Key lock	0000H: Key Enabled 0001H: Key Locked
		00E8H	Not used (*3)	
		↓	↓	
		00EFH	Not used (*3)	

(*3) For 'Not used' items, if a single piece of data Read/Write is executed, Error code 1 (31H, Shinko protocol) or Exception code 2 (02H, Modbus protocol) will be returned.

7.2.2 A Single Piece of Data Write Command

Shinko Command Type	Modbus Function Code	Data Item		Data
50H	06H	00FFH	Key operation change flag clearing (*4)	0000H: No action 0001H: Clear key operation change flag

(*4) For 00FFH (Key operation change flag clearing), if Read is executed, Error code 1 (31H, Shinko protocol) or Exception code 2 (02H, Modbus protocol) will be returned.

If Write is executed for any value other than 0001H (Clear key operation change flag), Error code 3 (33H, Shinko protocol) or Exception code 3 (03H, Modbus protocol) will be returned.

7.2.3 A Single/Multiple Piece(s) of Data Read Command

Shinko Command Type	Modbus Function Code	Data Item		Data
20H/24H	03H	0100H	PV	PV
20H/24H	03H	0101H	OUT1 MV	Current OUT1 MV
20H/24H	03H	0102H	OUT2 MV	Current OUT2 MV
20H/24H	03H	0103H	Current SV	Current SV
20H/24H	03H	0104H	Current running step	Running step
20H/24H	03H	0105H	Running step remaining time	Remaining time
20H/24H	03H	0106H	Status flag	0000 0000 0000 0000 2^{15} to 2^0 2^0 digit: OUT1 0: OFF 1: ON (Current output: Unfixed) 2^1 digit: OUT2 0: OFF 1: ON 2^2 digit: A1 output 0: OFF 1: ON 2^3 digit: A2 output 0: OFF 1: ON 2^4 to 2^7 digits: Not used (Always 0) 2^8 digit: Overscale 0: OFF 1: ON 2^9 digit: Underscale 0: OFF 1: ON 2^{10} digit: ON (STOP) / OFF (RUN) 0: ON (STOP) 1: OFF (RUN) 2^{11} digit: During AT 0: OFF 1: During AT 2^{12} digit: OUT/OFF key function 0: Control output ON/OFF 1: Program control 2^{13} digit: Controller/Converter 0: Controller 1: Converter 2^{14} digit: Not used (Always 0) 2^{15} digit: Change in key operation 0: No 1: Yes

Shinko Command Type	Modbus Function Code	Data Item		Data
20H/24H	03H	0108H	Software version	Software version No.
20H/24H	03H	0109H	Unit model information 1	0000 0000 0000 0000 2^{15} to 2^0 2^0 digit: Not used (Always 0) 2^1 digit: Heating/Cooling control output Enabled/Disabled 0: Disabled 1: Enabled 2^2 digit: Alarm 1 function Enabled/Disabled 0: Disabled 1: Enabled 2^3 digit: Alarm 2 function Enabled/Disabled 0: Disabled 1: Enabled 2^4 to 2^{15} digits: Not used (Always 0)
20H/24H	03H	010AH	Unit model information 2	0000 0000 0000 0000 2^{15} to 2^0 2^0 to 2^2 digits: Model 4: xxL 2^3 to 2^4 digits: OUT1 output type 0: R/M (Relay contact) 1: S/M (Non-contact voltage) 2: A/M (Direct current) 2^5 to 2^{15} digits: Not used (Always 0)

7.3 Data

7.3.1 Notes about Write/Read Command

- The data (set value, decimal) is converted to a hexadecimal number. Negative numbers are represented in 2's complement.
- When connecting multiple slaves, the address (instrument number) must not be duplicated.
- Do not use undefined Data items. If they are used, negative acknowledgement will be returned or a random value will be written or read, resulting in malfunction.
- Modbus protocol uses Holding Register addresses. The Holding Register addresses are created as follows. A Shinko command Data item is converted to decimal number, and the offset of 40001 is added. The result is the Holding Register address.
Using Data item 0001H (SV1) as an example: Data item in the sending message is 0001H, however, Modbus protocol Holding Register address is 40002 (1 + 40001).

7.3.2 Write Command

- Setting range of each item is the same as that of keypad operation.
- When data (set value) has a decimal point, a whole number (hexadecimal) without a decimal point is used.
- Writing via software communication will be possible even in the set value lock status.
- If the alarm type is changed in [A1 type (0023H or 0006H)] or in [A2 type (0024H or 0007H)], A1 value or A2 value will default to 0 (zero). Alarm output status will also be initialized.
- Even if options are not ordered, writing via software communication will be possible. However, their command contents will not function.
- The Communication protocol, Instrument Numbers, Communication Speed, Parity and Stop bit of the slave cannot be written by software communication. They can only be set via the keypad.
- When writing a command by Global address [95 (7FH), Shinko protocol] or Broadcast address [00H, Modbus protocol], the same command is sent to all the slaves connected. However, the response is not returned.
- Up to 1,000,000 (one million) entries can be stored in non-volatile IC memory. If the number of writings exceeds the limit, the data will not be saved. So, do not change the set values frequently via communication. (If a value written via software communication is the same as the value before writing, the value will not be written in non-volatile IC memory.)

7.3.3 Read Command

- When the data (set value) has a decimal point, a whole number (hexadecimal) without a decimal point is used for a response.

7.4 Negative Acknowledgement

The slave will return Error code 1 (31H, Shinko protocol) or Exception code 1 (01H, Modbus protocol) during PI control or ON/OFF control action in the following case:

- When AT Perform/Cancel (0003H or 00E2H) is read or written

The slave will return Error code 4 (34H, Shinko protocol) or Exception code 17 (11H, Modbus protocol) in the following cases:

- While AT is cancelled, and if 0003H or 00E2H (AT Perform/Cancel) is written to 0000H (AT Cancel)
- While AT is performing, and if 0003H or 00E2H (AT Perform/Cancel) is written to 0001H (AT Perform)

7.5 Notes on Programming Monitoring Software

7.5.1 How to Speed up the Scan Time

When monitoring multiple units of the controller, set the program so that the requisite minimum pieces of data such as Data item 0080H or 0100H (PV), Data item 0081H or 0101H (OUT1 MV), Data item 0085H or 0106H (Status flag), can be read. For other data, set the program so that they can be read only when their set value has changed.

This will speed up the scan time.

7.5.2 How to Read the Set Value Changes Made by Front Keypad Operation

If any set value is changed by the keypad operation, the controller sets 0085H or 0106H (Status flag, 2¹⁵: Change in key operation) to "1 (Yes)".

There are 2 methods of reading the set value changes made by front keypad.

(1) Reading method 1

- ① On the monitoring software side, check that 0085H or 0106H (Status flag, 2¹⁵: Change in key operation) has been set to "1 (Yes)", then read all set values.
- ② Clear 0085H or 0106H (Status flag, 2¹⁵: Change in key operation), by writing Data item 0070H or 00FFH (Key operation change flag clearing) to 0001H (Clear key operation change flag).
If 0070H or 00FFH (Key operation change flag clearing) is written to 0001H (Clear key operation change flag) during the setting mode of the controller, Error code 5 (35H, Shinko protocol) or Exception Code 18 (12H, Modbus protocol) will be returned as a negative acknowledgement. And 0085H or 0106H (Status flag, 2¹⁵: Change in key operation) cannot be cleared.
Set a program so that all set values can be read when a negative acknowledgement is returned.
- ③ Read all set values again after acknowledgement is returned.

(2) Reading method 2

- ① On the monitoring software side, check that 0085H or 0106H (Status flag, 2¹⁵: Change in key operation) has been set to "1 (Yes)", then write 0070H or 00FFH (Key operation change flag clearing) to 0001H (Clear key operation change flag).
- ② Set the program depending on the acknowledgement or negative acknowledgement as follows.
When acknowledgement is returned;
Consider it as settings completed, and read all set values.
When Error code 5 (35H, Shinko protocol) or Exception code 18 (12H, Modbus protocol) is returned as a negative acknowledgement;
Consider it as still in setting mode, and read the requisite minimum pieces of data such as 0080H or 0100H (PV), 0081H or 0101H (OUT1 MV), 0085H or 0106H (Status flag), then return to Step ①.

Thus, programs which do not affect the scan time can be created using the methods described above, even if set values on the monitoring software will not be updated until settings are complete.

7.5.3 How to Read PID Parameters after AT Finishes

While AT is performing, this controller sets 0085H or 0106H (Status flag, 2¹¹: During AT) to "1 (During AT)".

After AT is finished, PID parameters are updated.

On the monitoring software side, check that 0085H or 0106H (Status flag, 2¹¹: During AT) has been set to "0 (OFF)", then read parameters such as P, I, D, ARW.

7.5.4 Note When Sending All Set Values Simultaneously

- When changing alarm types at 0023H or 0006H (A1 type), 0024H or 0007H (A2 type), A1 value or A2 value will default to 0 (zero).
First, send the selected alarm type, then send each alarm value.
- When changing input types at 0044H or 0002H (Input type), the set values such as SV1, OUT1 proportional band, A1 value will be initialized.
First, send the selected input type, then send other set values.

7.6 When Communicating with a PLC

To communicate with a PLC, use the SIF-600, Shinko PLC Interface Unit.

No programming is needed for connection. However, Shinko protocol Multiple pieces of data Read (24H) and Multiple pieces of data Write (54H) are not available.

PLCs corresponding to the SIF-600, its manufacturer and host link units:

PLC manufacturer	PLC model	Host link unit model
Mitsubishi Electric Corp.	MELSEC Q, QnA series (*)	AJ71UC24, A1SJ71UC24-R2/R4/PRF A1SJ71C24-R2/R4/PRF, QJ71C24
	MELSEC FX series (*)	
Omron Corp.	SYSMAC CJ series	CS1W-SCU21-V1 CJ1W-SCU21, CJ1W-SCU41
Keyence Corp.	KV	KV-L20V
Yokogawa Electric Corp.	FA-M3	F3LC11-2N, F3LC11-1F, F3LC12-1F
Fuji Electric Co., Ltd.	MICREX-SX series	NP1L-RS1, NP1L-RS2, NP1L-RS3, NP1L-RS4

(*) Models with compatible QR/QW communication commands.

8. SV Digital Transmission

By connecting to Shinko programmable controllers [PCA1 or PCB1 (with C5 option)], the step SV can be digitally transmitted.

8.1 Wiring

When connecting to the PCB1, connect YA (-) to YA (-), YB (+) to YB (+), SG to SG respectively. Up to 31 units of the JCL-33A can be connected.

The following shows a connection example of PCB1 and JCL-33A (Fig. 8.1-1).

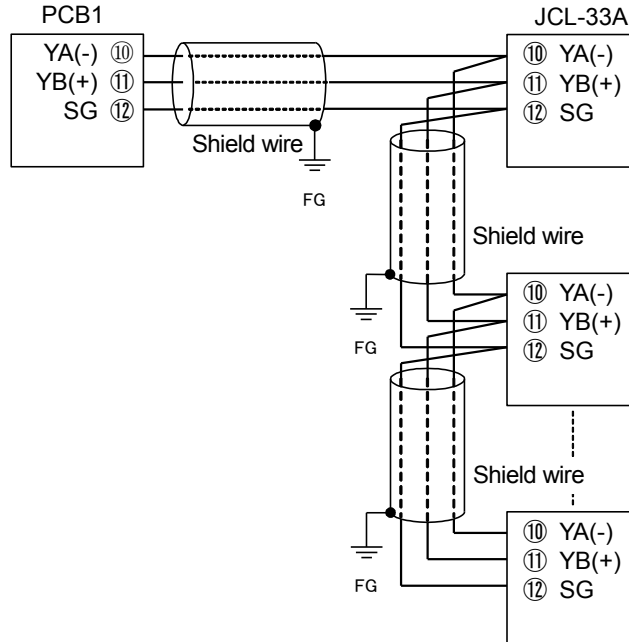

(Fig. 8.1-1)

8.2 Setting Communication Parameters

To use the SV digital transmission function between PCB1 and JCL-33A, communication parameters should be set as follows. Refer to the Instruction Manual for the JCL-33A and PCB1 for details.

Setting Method of Controllers

(1) Setting the PCB1

Select "SV digital transmission (Shinko protocol)" in [Communication protocol].

(2) Setting the JCL-33A

Check the following settings in Auxiliary function setting mode 1.

Refer to Section '3 Setting Communication Parameters' (p.4).

- Shinko protocol has been selected in [Communication protocol].
- Communication speed of the JCL-33A is identical with that of PCB1.

(3) The SV Digital Transmission starts.

Enter the program values on the PCB1, and press the **RUN** key to perform program control. Step SV of the PCB1 will be transmitted to the JCL-33A.

During program control stop (or in standby mode), 0 (zero) is sent to the JCL-33A.

9. Specifications

Cable length	1.2 km (Max.), Cable resistance: Within 50 Ω (Terminators are not necessary, but if used, use 120 Ω or more on both sides.)			
Communication line	EIA RS-485			
Communication method	Half-duplex communication			
Communication speed	2400, 4800, 9600, 19200, 38400 bps (Selectable by keypad)			
Synchronization method	Start-stop synchronization			
Code form	ASCII, Binary			
Communication protocol	Shinko protocol, Modbus ASCII, Modbus RTU In addition, each protocol above is available with Block Read/Write.			
Data format	Communication protocol	Shinko protocol	Modbus ASCII	Modbus RTU
	Start bit	1	1	1
	Data bit	7	7	8
	Parity	Even	Even (No parity, Odd) Selectable	No parity (Even, Odd) Selectable
	Stop bit	1	1 (2) Selectable	1 (2) Selectable
Number of connectable units	Max 31 units to 1 host computer			
Error correction	Command request repeat system			
Error detection	Parity check, checksum (Shinko protocol), LRC (Modbus ASCII), CRC-16 (Modbus RTU)			
Digital external setting	Receives digital SV from Shinko programmable controllers (PCA1 or PCB1 with C5 option).			

10. Troubleshooting

Check that power is being supplied to the master and slave that customers use. If communication failure still occurs, check the following.

Problem	Possible Cause	Solution
Communication failure	Communication cable is not securely connected, or is disconnected/defective.	Check the communication cable and connector.
	Incorrect wiring of the communication cable and/or connector	Check the communication cable and connector. Refer to Section '2. Wiring' (pp. 2, 3).
	Imperfect contact between the communication cable and the connector, or between the communication connector and instrument port	Check the communication cable and connector.
	Communication speed of the slave does not match that of the master.	Set the same communication speed on the master and the slave. Refer to Section '3. Setting Communication Parameters' (p. 4).
	The data bit, parity and stop bit of the master do not correspond to those of the slave.	Set the same data bit, parity and stop bit on the master and the slave. Refer to Section '3. Setting Communication Parameters' (p. 4).
	The instrument number (address) of the slave does not correspond to that of the command.	Check the instrument number (address) of the slave and the command. Refer to Section '3. Setting Communication Parameters' (p. 4).
	The instrument numbers (addresses) are duplicated in multiple slaves.	Check that each slave has a different instrument number (address). Refer to Section '3. Setting Communication Parameters' (p. 4).
	Make sure that the program is appropriate for the transmission timing.	Check the program. Refer to Section '4. Communication Procedure' (p. 5).
Although communication is occurring, the response is negative acknowledgement.	A non-existent command code has been sent.	Check the command code. Refer to Section '7. Communication Command Table' (pp.21 to 29).
	The Write command data exceeds the setting range of the slave.	Check the setting range of the slave.
	The controller cannot be written when functions such as AT are performing.	Check the slave status.
	The instrument is in front keypad operation setting mode.	Return the instrument to RUN mode.

For all other malfunctions, please contact our main office or dealers.

