

NCL-13A



Remote Operation from Your PC!

Control and Communication Functions in a Slimline Unit!

Shinko

Features

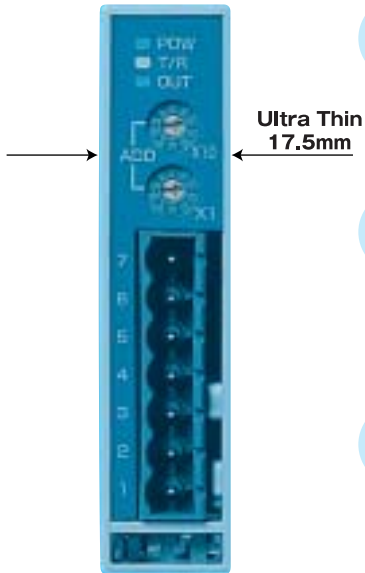

(Actual size)

Small and space saving

Width: 17.5mm, Height: 75mm, Depth: 85mm (excluding the plug)
Its compactness ensures easy mounting when only limited space permits.

Multi-input

18 type of inputs such as thermocouple (10 types), RTD (2 types), DC current (2 types), DC voltage (4 types) are available.
Fast 0.25-second input sampling period allows applications for various processes.

Multi-drop communication

Various operations and settings can be carried out from PCs and programmable interfaces through communication function (Up to 31 units of the NCL-33A can be connected.)
For the communication protocol, Shinko protocol and Modbus protocol are available. (For Modbus protocol, RTU mode and ASCII mode can be selected by the DIP switch.)
Connection to the open network Modbus is possible.

Standard 4 alarm points

Four points of alarm are standard feature.
However, for Alarm 2, Alarm 3 and Alarm 4, the output and Energized/Deenergized functions are not available.

Easy mounting, removal and maintenance

Hook the NCL-13A into the DIN rail, then fit the unit to the DIN rail.
Since the unit is fixed tightly to the DIN rail, it is resistant to vibration, whereby ensuring ease of maintenance.

Wiring is not necessary

Using a screw type plug, the power and communication lines can be connected. Bus plugs enable multiple connection of the NCL-13A units.
The spring type plug for input and output can also be connected or removed.

Safety standard

UL/CSA, CE marking: Approval pending.

Specifications

Model name

NCL-13A-□/M □□□□			
Control output	R	Relay contact	
	S	Non-contact voltage (for SSR drive)	
	A	DC current	
	C	Open collector	
Input	M	Multi-input	
Option	W (20A)	Single phase	Heater burnout alarm/Actuator short circuit alarm
	W (100A)		
	W3 (20A)	3-phase	
	W3 (100A)		
	DC	Heating/Cooling control output	

Specify your specification from the above □, □□ columns.
When adding options, enter them by punctuating with a comma.

Rated range (Full multi-range)

	Input type	Input range	
Thermocouple	K	-200 to 1370 °C	-320 to 2500 °F
	J	-199.9 to 500.0 °C	-199.9 to 932.0 °F
	R	-200 to 1000 °C	-320 to 1800 °F
	S	0 to 1760 °C	0 to 3200 °F
	B	0 to 1820 °C	0 to 3300 °F
	E	0 to 1760 °C	0 to 3200 °F
	T	0 to 1820 °C	0 to 3300 °F
	N	-200 to 800 °C	-320 to 1500 °F
	PL-II	-199.9 to 400.0 °C	-199.9 to 750.0 °F
	C(W/Re5-26)	-200 to 1300 °C	-320 to 2300 °F
RTD	Pt100	0 to 2500 °F	0 to 1393 °C
	JPt100	-200 to 850 °C	-300 to 1500 °F
		-199.9 to 850.0 °C	-199.9 to 999.9 °F
DC current	DC 4 to 20mA	-199.9 to 900 °F	-199.9 to 900.0 °C
	DC 0 to 20mA	-199.9 to 900 °F	-199.9 to 900.0 °C
DC voltage	DC 0 to 1V	-1999 to 9999	-1999 to 9999
	DC 0 to 10V	-1999 to 9999	-1999 to 9999
	DC 1 to 5V	-1999 to 9999	-1999 to 9999
	DC 0 to 5V	-1999 to 9999	-1999 to 9999

* For DC current input, connect 50 Ω shunt resistor (RES-S03-050, sold separately) between input terminals.

Name and functions of the sections

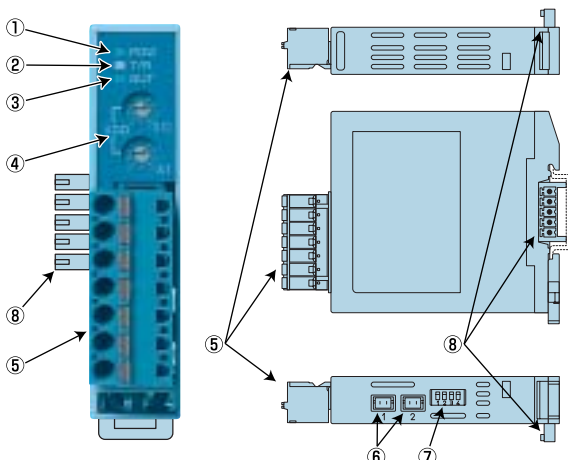

- Power indicator (POW)**
A green LED lights up when the instrument is switched on.
A green LED flashes when an alarm (temperature alarm, Heater burnout alarm/Actuator short circuit alarm, Loop break alarm) is activated.
- Communication indicator (T/R)**
A yellow LED lights up during Serial communication TX output.
- Control output indicator (OUT)**
When Control output is ON, green LED lights up. For DC current output, a green LED flashes corresponding to the output manipulated variable.
- Rotary switch for instrument setting**
Sets the instrument number of the NCL-13A.
- Spring type plug**
Plug for the input, control output and Event output.
- CT1, CT2 input connectors**
Connectors for CT input of Heater burnout alarm/Actuator short circuit alarm (Option: W, W3)
- DIP switch for Communication speed and Communication protocol**
Dip switch for selecting Communication speed and Communication protocol
- Bus plug**
Plug for lines (Power bus, Communication bus)
When connecting multiple units, the bus plug can connect to another bus plug.

Standard specifications

Action indicators	<p>POW (Power indicator) ----- A green LED lights up when the power to the NCL-13A is turned on. Flashes if an alarm occurs (Temperature alarm, Heater burnout alarm/Actuator short circuit alarm, Loop break alarm).</p> <p>T/R (Communication indicator) -- A yellow LED lights up during serial communication TX output.</p> <p>OUT (Control output indicator) --- A green LED lights up when the control output is ON. For DC current output, this flashes corresponding to the output MV.</p>
Input	<p>Thermocouple ---- K, J, R, S, B, E, T, N, PL-II, C (W/Re5-26) External resistance: 100 Ω or less (However, for B input, 40 Ω or less)</p> <p>RTD ----- Pt100, JPt100 3-wire system (Allowable input lead wire resistance: 10 Ω or less per wire)</p> <p>DC current ----- 0 to 20mA DC, 4 to 20mA DC: Input impedance: 50 Ω (Connect 50 Ω shunt resistor between input terminals.) Allowable input current: 50mA DC or less (When 50 Ω shunt resistor is used)</p> <p>DC voltage ----- 0 to 1V DC Input impedance: 1M Ω or greater Allowable input voltage: 5V or less, Allowable signal source resistance: 2k Ω or less</p> <p>0 to 5V DC, 1 to 5V DC, 0 to 10V DC Input impedance: 100k Ω or greater Allowable input voltage: 15V or less, Allowable signal source resistance: 100 Ω or less</p>
Accuracy (Setting · indication)	<p>Thermocouple ---- Within ±0.2% of each input span ±1 digit, or within ±0.2°C (4°F), whichever is greater However, R, S inputs, 0 to 200°C (0 to 400°F): Within ±6°C (12°F) B input, 0 to 300°C (0 to 600°F): Accuracy is not guaranteed.</p> <p>K, J, E, T, N inputs, 0°C (32°F) or less: Within ±0.4% of each input span ±1 digit</p> <p>RTD ----- Within ±0.1% of each input span ±1 digit or within ±1°C (2°F), whichever is greater</p> <p>DC current ----- Within ±0.2% of each input span ±1 digit</p> <p>DC voltage ----- Within ±0.2% of each input span ±1 digit</p>
Input sampling period	0.25 seconds
Control output (OUT)	<p>Relay contact ----- 1a, 250V AC 3A (resistive load), 250V AC 1A (inductive load $\cos \phi = 0.4$), Electric life: 100,000 times</p> <p>Non-contact voltage --- 12⁺V DC, Max. 40mA DC (short circuit protected)</p> <p>DC current ----- 4 to 20mA DC, Load resistance: Max. 550 Ω (Output accuracy: Within ±0.3% of output span, Resolution: 12000)</p> <p>Open collector ----- 24V DC, Max. 100mA DC (isolation type)</p>
Control action	<p>PID (with auto-tuning), PI, PD (with manual reset), ON/OFF</p> <p>OUT1 proportional band (P) -- 0.0 to 110.0% (Default: 2.5%)</p> <p>Integral time (I) ----- 0 to 1000s (Off when set to 0) (Default: 200s)</p> <p>Derivative time (D) ----- 0 to 300s (Off when set to 0) (Default: 50s)</p> <p>OUT1 proportional cycle ----- 1 to 120s (Default: -R/M 30s, -S/M 3s, -C/M 3s, -A/M Unavailable)</p> <p>ARW ----- 0 to 100% (Default: 50%)</p> <p>OUT1 ON/OFF hysteresis ---- 0.1 to 100.0°C (°F) (Default: 1.0°C)</p> <p>DC current, DC voltage: 1 to 1000</p> <p>OUT1 output limit ----- 0 to 100% (DC current output: -5 to 105%, Ineffective when ON/OFF action) (Default: OUT1 low limit 0%, high limit 100%)</p>
Alarm	<p>Alarm 1 output: When Alarm 1 action Energized is selected during Alarm 1 Energized/Deenergized selection mode, the alarm action point is set by ±Deviation from the SV (Except Process alarm). When the input goes out of the range, the Event output is turned ON or OFF (for High/Low limit range alarm). When the action Deenergized is selected, the output acts conversely. This alarm shares output terminals with Loop break alarm and Heater burnout alarm/Actuator short circuit alarm (option W, W3). When option DC is applied, the Event output becomes cooling output. Therefore Alarm 1, Loop break alarm and Heater burnout alarm/Actuator short circuit alarm cannot be outputted.</p> <ul style="list-style-type: none"> • No alarm action • High limit alarm (Deviation setting) Setting range: -(Scaling span) to Scaling span • Low limit alarm (Deviation setting) Setting range: -(Scaling span) to Scaling span • High/Low limits alarm (Deviation setting) Setting range: 0 to Scaling span • High/Low limit range alarm (Deviation setting) Setting range: 0 to Scaling span • Process high alarm Setting range: Scaling low limit to Scaling high limit value • Process low alarm Setting range: Scaling low limit to Scaling high limit value • High limit alarm with standby (Deviation setting) Setting range: -(Scaling span) to Scaling span • Low limit alarm with standby (Deviation setting) Setting range: -(Scaling span) to Scaling span • High/Low limits alarm with standby (Deviation setting) Setting range: 0 to Scaling span <p>Off when set to 0 or 0.0 (except the Process high and Process low alarms). When the input has a decimal point, the negative lower limit value is -199.9 or -1999, and the positive upper limit value is 999.9 or 9999. (Default: 0)</p> <p>Setting accuracy ----- The same as the Accuracy above</p> <p>Action ----- ON/OFF action</p> <p>Hysteresis setting range --- Thermocouple, RTD: 0.1 to 100.0°C (°F) (Default: 1°C) DC current, DC voltage: 1 to 1000</p> <p>Output ----- Open collector, Control capacity: 24V DC 0.1A</p> <p>Alarm hold function ----- Once the alarm is activated, the alarm output is maintained until the power supply to the instrument is turned off, or until the alarm flag is reset by the Alarm hold reset command. (Default: Alarm Hold Not used)</p> <p>Alarm hold reset ----- Can reset the alarm flag by the Communication command (0051H). (0001H: Reset including the standby 0002H: Reset of the alarm flag only.)</p> <p>Alarm 2, Alarm 3 and Alarm 4: Action and type are the same as the above. However, the output and Energized/Deenergized action are not available. The status can be read by reading the status flag in serial Communication.</p>
Loop break alarm [LA]	<p>Detects the actuator abnormality (Heater burnout, sensor burnout). This alarm shares output terminals with Alarm 1 output, Heater burnout alarm/Actuator short circuit alarm (option W, W3). If the option DC is selected, the Event output becomes the cooling output. Therefore Alarm 1, Loop break alarm and Heater burnout alarm/Actuator short circuit alarm are not outputted.</p> <p>Loop break alarm time setting ---- 0 to 200 minutes (Default: 0 minutes)</p> <p>Loop break alarm span setting --- Thermocouple, RTD: 0 to 150°C (°F) or 0.0 to 150.0°C (°F) (Default: 0°C) DC current, DC voltage: 0 to 1500</p> <p>Output ----- Open collector, Control capacity: 24V DC 0.1A</p>

Serial communication	Change of the functions, setting and reading of the values of the NCL-13A can be performed from the host computer. (The setting data is backed up in the non-volatile IC memory.) Communication interface -- Based on EIA RS-485 Communication method ---- Half-duplex communication start-stop synchronous Communication speed ----- 4800, 9600, 19200bps (Selectable by the DIP switch)																														
	<table border="1"> <thead> <tr> <th colspan="2">DIP switch number</th> <th rowspan="2">Communication speed (bps)</th> </tr> <tr> <th>1</th> <th>2</th> </tr> </thead> <tbody> <tr> <td>OFF</td> <td>OFF</td> <td>9600</td> </tr> <tr> <td>ON</td> <td>OFF</td> <td>4800</td> </tr> <tr> <td>OFF</td> <td>ON</td> <td>19200</td> </tr> </tbody> </table>	DIP switch number		Communication speed (bps)	1	2	OFF	OFF	9600	ON	OFF	4800	OFF	ON	19200																
	DIP switch number		Communication speed (bps)																												
1	2																														
OFF	OFF	9600																													
ON	OFF	4800																													
OFF	ON	19200																													
Instrument number ----- Address 0 to 95 (Selectable with 2 Rotary switches.) Communication protocol---- Shinko protocol, Modbus ASCII or Modbus RTU mode (Selectable with the DIP switch)																															
	<table border="1"> <thead> <tr> <th colspan="2">DIP switch number</th> <th rowspan="2">Communication protocol</th> <th rowspan="2">Start bit</th> <th rowspan="2">Data length</th> <th rowspan="2">Stop bit</th> <th rowspan="2">Parity</th> </tr> <tr> <th>3</th> <th>4</th> </tr> </thead> <tbody> <tr> <td>OFF</td> <td>OFF</td> <td>Shinko protocol</td> <td>1 bit</td> <td>7 bits</td> <td>1 bit</td> <td>Yes (Even)</td> </tr> <tr> <td>ON</td> <td>OFF</td> <td>Modbus ASCII</td> <td>1 bit</td> <td>7 bits</td> <td>1 bit</td> <td>Yes (Even)</td> </tr> <tr> <td>OFF</td> <td>ON</td> <td>Modbus RTU</td> <td>1 bit</td> <td>8 bits</td> <td>1 bit</td> <td>No</td> </tr> </tbody> </table> <p>* The contents set by DIP switch and Rotary switch become effective when the power to the unit is turned on. Therefore, values changed after the power was turned on are not effective.</p>	DIP switch number		Communication protocol	Start bit	Data length	Stop bit	Parity	3	4	OFF	OFF	Shinko protocol	1 bit	7 bits	1 bit	Yes (Even)	ON	OFF	Modbus ASCII	1 bit	7 bits	1 bit	Yes (Even)	OFF	ON	Modbus RTU	1 bit	8 bits	1 bit	No
DIP switch number		Communication protocol	Start bit						Data length	Stop bit	Parity																				
3	4																														
OFF	OFF	Shinko protocol	1 bit	7 bits	1 bit	Yes (Even)																									
ON	OFF	Modbus ASCII	1 bit	7 bits	1 bit	Yes (Even)																									
OFF	ON	Modbus RTU	1 bit	8 bits	1 bit	No																									
Supply voltage	24V DC Allowable voltage fluctuation range: 20 to 28V DC																														
Power consumption	Approx. 2 W																														
Isolation resistance	10MΩ or greater at 500V DC																														
Dielectric strength	Non-contact voltage (-S/M), DC current (-A/M), Open collector (-C/M) output: Between input terminal and power terminal ----- 0.5kV AC for 1 minute Between output terminal and power terminal ---- 0.5kV AC for 1 minute Relay contact (-R/M) output: Between input terminal and power terminal ----- 0.5kV AC for 1 minute Between output terminal and power terminal ---- 1.5kV AC for 1 minute																														
Environment	Ambient temperature: 0 to 50℃ Ambient humidity: 35 to 85%RH (Non-condensing)																														
Material • Color	Case and base: Flame resistant resin, Light gray Bus plug and spring type plug: Polyamide, Light gray																														
Mounting method	DIN rail mounting																														
Setting system	Receives setting values from the host computer.																														
External dimensions	W17.5×H75×D85mm																														
Weight	Approx. 85g																														
Attached functions	Self-diagnosis (All outputs OFF when abnormal), Automatic cold junction temperature compensation (for thermocouple only), Burnout, Output status selection when input abnormal, Sensor correction, PV filter, Power failure countermeasure, Non-volatile memory saving selection																														
Required plug sold separately	Screw type plug for lines (Only one plug is required regardless of the number of NCL-13A units connected.)																														

Options

[Specify the option code according to users' needs.]

Heater burnout alarm/ Actuator short circuit alarm Single phase [W], Three-phase [W3]	<p>This option cannot be applied to DC current output type. By adding this option, the heater current is watched by the current transformer (CT), then the heater burnout can be detected. Specify one heater rated current either 20A or 100A. Setting accuracy ---- Within ±5% of the rated value Action ----- ON/OFF action Output ----- Open collector, Control capacity: 24V DC 0.1A Output self-holding -- Not available Accessories ----- Option W (20A) : Wire harness 3m 1 length, CT(CTL-6S) 1 piece Option W (100A) : Wire harness 3m 1 length, CT(CTL-12-S36-10L1) 1 piece Option W3 (20A) : Wire harness 3m 2 lengths, CT(CTL-6S) 2 pieces Option W3 (100A) : Wire harness 3m 2 lengths, CT(CTL-12-S36-10L1) 2 pieces</p>
Heating/Cooling control output [DC]	<p>By applying this option, Control output 2 can be added, and Heating/Cooling control can be performed. If the option DC is selected, the Event output works as a cooling action. Therefore Alarm 1, Loop break alarm, Heater burnout alarm/ Actuator short circuit alarm will not be outputted. For the control output type, only an open collector output (DC) is available. Heating control action: The same as the control output (OUT). Cooling control action: OUT2 proportional band ----- 0.0 to 10.0 times Control output (OUT1) proportional band (ON/OFF action when set to 0.0) Integral time (I) ----- The same as that of Control output (OUT1) integral time Derivative time (D) ----- The same as that of Control output (OUT1) derivative time OUT2 proportional cycle ----- 1 to 120 seconds (Default: 3s) Overlap band/Dead band ----- Thermocouple, RTD: —100.0 to 100.0℃ (°F) DC current, DC voltage: —1000 to 1000 OUT2 ON/OFF hysteresis ----- Thermocouple, RTD: 0.1 to 100.0℃ (°F) DC current, DC voltage: 1 to 1000 OUT2 high limit, OUT2 low limit -- 0 to 100% (Not available for ON/OFF action) (Default: OUT2 low limit; 0%, OUT2 high limit; 100%) OUT2 action mode selection • Air cooling : Linear characteristic (Default) • Oil cooling : 1.5th power of the linear characteristic • Water cooling : 2nd power of the linear characteristic</p>

Terminal arrangement

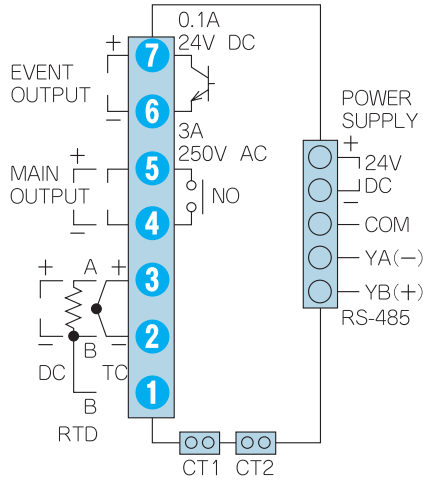

POWER SUPPLY

Power supply terminals

EVENT OUTPUT

Event output terminals [Alarm 1 (shares output terminals with Heater burnout alarm/Actuator short circuit alarm and Loop break alarm) or Cooling control output.]

MAIN OUTPUT

Main control output terminals

RS-485

Serial communication terminals

CT1, CT2

CT (current transformer) input terminals
These terminals are attached only when the option Heater burnout alarm is applied.

TC

Thermocouple input terminals

RTD

RTD input terminals

DC

DC current, voltage input terminals

External dimensions

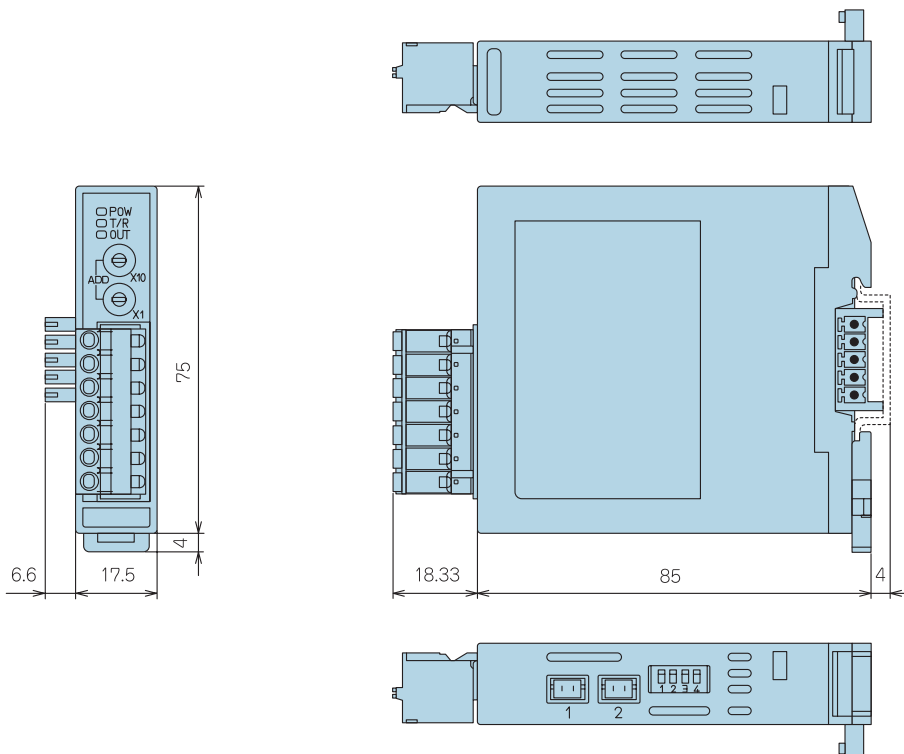

CT dimensions

CTL-6-S (for 20A)

CTL-12-S36-10L1 (for 100A)

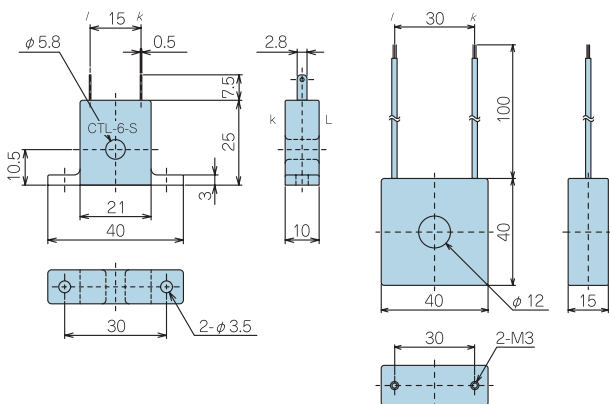

DIN rail mounting (Applicable DIN rail specifications)

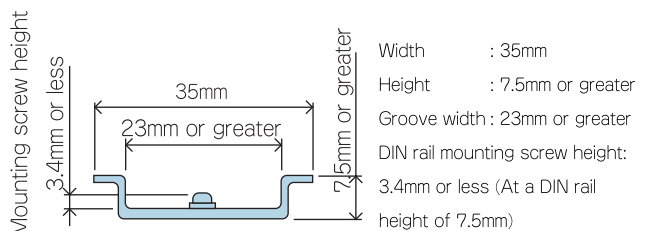

Configuration example

When monitoring multiple NCL-13A units with a personal computer (Basic configuration)

If a personal computer is connected to the NCL-13A units via a Communication converter, up to 31 temperature control points can be monitored. (The communication converter is not necessary if RS-485 communication lines for the personal computer are used.)

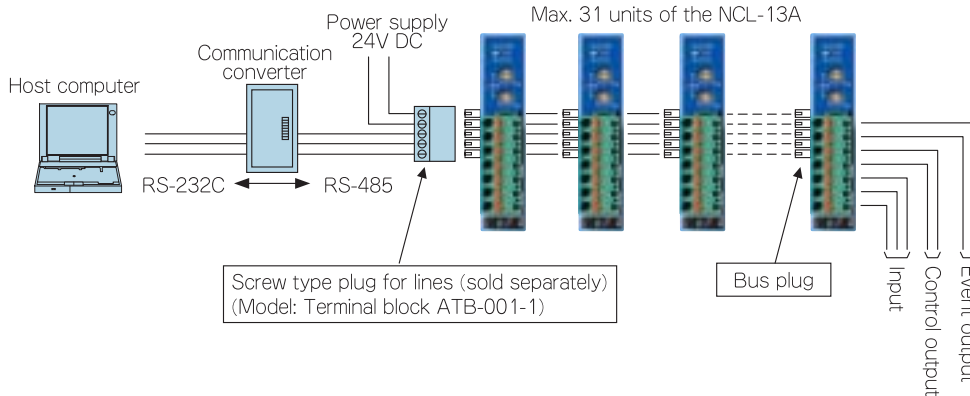

When monitoring multiple NCL-13A units with a touch panel unit

By connecting to a touch panel unit (programmable interface), up to 31 points of temperature control and monitoring can be performed. The NCL-13A complies with the following touch panel units.
 Digital Electronics Corp.: GLC series, GP series
 Hakko Electronics Co. Ltd.: V7 series, V6 series

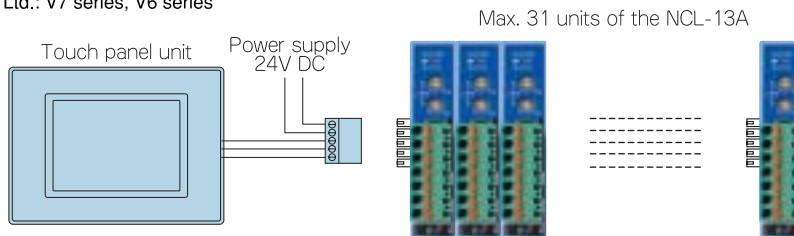

When connecting a maximum of 31 units of the NCL-13A with the PLC

A maximum of 31 units of the NCL-13A can be connected with the PLC via PLC interface unit SIF-400. Please contact us to determine which PLCs correspond to the SIF-400.

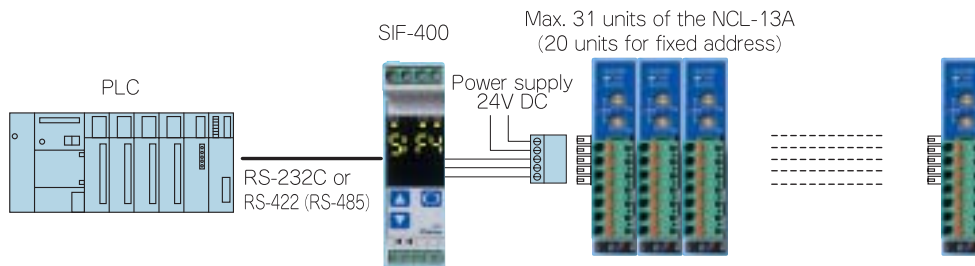

SAFETY PRECAUTIONS

- To ensure safe and correct use, thoroughly read and understand this manual before using this instrument.
- This instrument is intended to be used for industrial machinery, machine tools and measuring equipment. Verify correct usage after consulting purpose of use with our agency or main office. (Never use this instrument for medical purposes with which human lives are involved.)
- External protection devices such as protection equipment against excessive temperature rise, etc. must be installed, as malfunction of this product could result in serious damage to the system or injury to personnel. Also proper periodic maintenance is required.
- This instrument must be used under the conditions and environment described in this manual. Shinko Technos Co., Ltd. does not accept liability for any injury, loss of life or damage occurring due to the instrument being used under conditions not otherwise stated in this manual.

Caution with respect to Export Trade Control Ordinance

To avoid this instrument from being used as a component in, or as being utilized in the manufacture of weapons of mass destruction (i.e. military applications, military equipment, etc.), please investigate the end users and the final use of this instrument. In the case of resale, ensure that this instrument is not illegally exported.



- This catalog is as of June 2004. Specifications and external appearance are subject to change without prior notice.
- If you have any inquiries, please consult our agency or with us directly.

Shinko
North America Ltd.

25 Whitefriars Drive
 Toronto ON, Canada M3A 2L2
 Tel: 416 444-0817
 Fax: 416 444-2361
 Toll Free: 1 - 866-4SHINKO