

## Sensing Fluid Temperature with Thermal-Ribbons

---

**MOD-TRONIC Instruments Ltd · 1 Delta Park Blvd, #12 Brampton, ON L6T 5G1 · 1-800-794-5883 · [www.mod-tronic.com](http://www.mod-tronic.com)**

The logo for MINCO features the word "MINCO" in a bold, blue, sans-serif font. A small orange triangle is positioned above the letter "I".

## Table of Contents

|                                             |        |
|---------------------------------------------|--------|
| Abstract .....                              | Page 3 |
| What are Thermal-Ribbons? .....             | Page 3 |
| Thermal Profile of a Pipe .....             | Page 3 |
| How Thermometers Affect Fluid Systems ..... | Page 4 |
| Sensor Comparison .....                     | Page 5 |
| Thermal-Ribbon Installation.....            | Page 6 |
| Summary.....                                | Page 7 |

## Abstract

Accurate temperature sensing of liquids flowing in pipes is essential to process control and energy management systems. The traditional approach is to use probe-style sensors and thermowells inserted into the fluid stream. These immersed sensors can be costly and difficult to install, especially when retrofitted to existing facilities. This study shows how thermal-ribbon flexible RTDs make an economical alternative to thermowells, offering surface-mounted simplicity with no loss of accuracy.

### What are Thermal-Ribbons?

Thermal-ribbons are thin, flexible resistance thermometers. They contain flat wire-wound elements laminated between layers of electrical insulation. This design improves thermal response in three ways:

1. Flexible sensors conform tightly to sensed surfaces, leaving no air gaps to block heat transfer.
2. Thin electrical insulation reduces the thermal gradient between the sensing element and sensed surface. Response is rapid and self-heating is negligible.
3. The element winding senses over an area to reduce point measurement errors.

To see how these benefits apply to fluid measurement, we need to examine the thermal profile of fluid systems.

### Thermal Profile of a Pipe

What is the temperature of a liquid flowing inside a pipe? It depends on where you sense it. Assuming the fluid is warmer than the ambient air, the highest temperature exists at the center of the flow. Temperature gradually declines as you move to the outside wall of the pipe then drops off sharply through the insulation.

Figure 1 shows the temperature cross-section of a well-insulated pipe. Although the maximum reading is at the pipe's center, all points inside the insulation, including the pipe wall, are at nearly the same temperature. Why then the difference between immersion and surface sensing?

The problem is conduction. When you introduce a thermometer into a system, it conducts heat away from its own sensing element to the outside environment. The element actually detects a temperature somewhere between true fluid temperature and the ambient air.

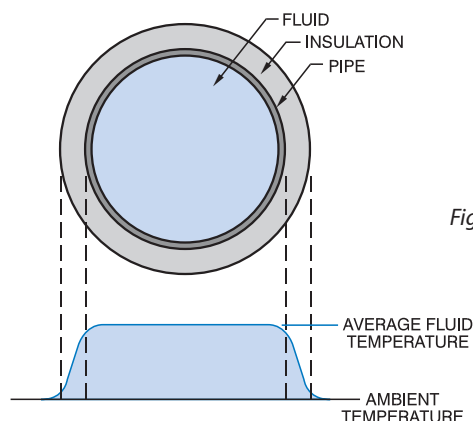

Figure 1: Thermal profile of an insulated pipe

## How Thermometers Affect Fluid Systems

Figure 2 shows a typical thermowell/sensor installation. The metal thermowell and connection head conduct heat from the sensing area to the air outside the pipe insulation. A large gradient appears along the well. Errors can result if the thermowell tip does not penetrate far enough into the fluid stream.

The major drawback to thermowells is their installation complexity. Pipes must be drained, holes drilled, fittings welded, and threads tapped. In many instances, such as retrofit installations, the cost of hiring specialized personnel and altering plumbing leads us to look for a simpler solution. Why not install a thermometer on the pipe's surface?

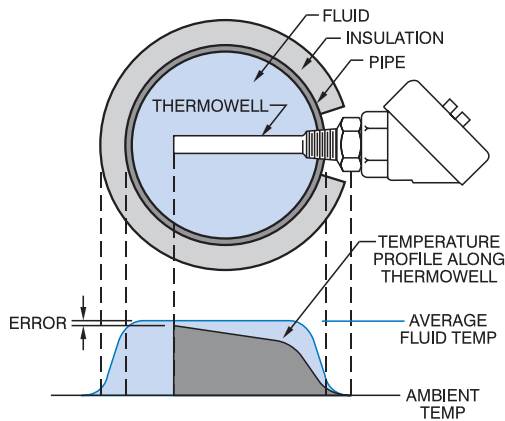

Figure 2: Thermal profile using a probe and thermowell

In Figure 3 we've replaced the thermowell with a surface sensor. It consists of a spring-loaded probe clamped to the pipe, with a junction box for leadwire connections.

This arrangement is almost guaranteed to produce errors. Ambient air directly cools the pipe surface through the opening in the insulation. Heat also flows through the probe into the junction box, which presents a large surface for radiant and conductive heat loss. The sensing element transmits an uncertain mixture of fluid and ambient temperatures. A better approach is needed for surface sensing.

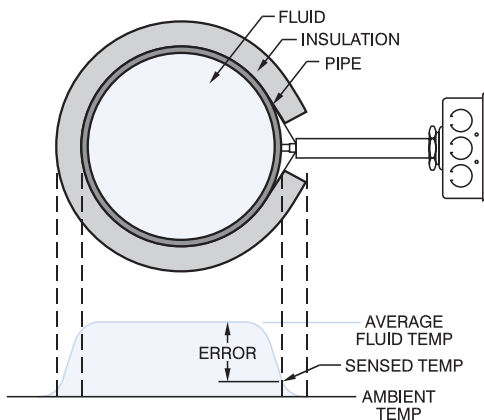

Figure 3: Surface mounted sensor

Figure 4 shows a thin, flexible thermal-ribbon inserted beneath the insulating blanket. Two leadwires form the only possible route for heat loss. Here we've returned to the thermal profile of Figure 1. As long as the pipe has sufficient insulation, its outside surface temperature agrees with the fluid inside.

Note that insulation is a must. Exposing the thermal-ribbon to outside air will reduce its accuracy.

The thermal profiles shown are approximations. Actual values depend on pipe size, fluid temperature, flow rate, insulation rating, and other variables.

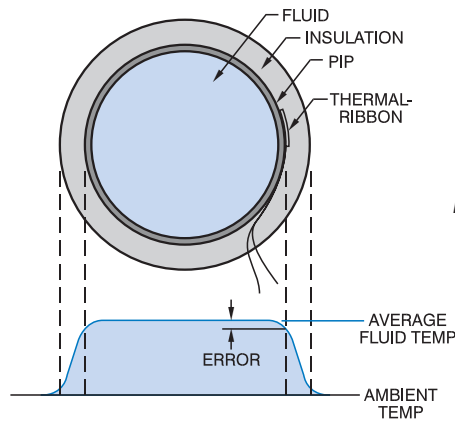

Figure 4: Thermal-ribbon

### Sensor Comparison

Is thermal-ribbon performance truly comparable to immersed sensors? Shown below are test data comparing a thermal-ribbon against a thermowell installation. The test conditions were:

1. The thermal-ribbon was mounted to the top of a 3" steel pipe with stretch tape, then covered with 3" of fiberglass insulation.
2. A 12" long brass thermowell probe assembly was longitudinally installed beneath the thermal-ribbon. Brass was chosen for the thermowell material because it conducts heat 7 to 8 times better than stainless steel.
3. A bare tip-sensitive probe was inserted into the fluid as a control.
4. To test time response, flowing water was abruptly switched from 50°F to 150°F. The result was:

| Sensor type         | Initial reading | After 1 minute | After 5 minutes |
|---------------------|-----------------|----------------|-----------------|
| Thermal-ribbon      | 50°F            | 131°F          | 150°F           |
| Thermowell assembly | 50°F            | 109°F          | 150°F           |
| Control probe       | 50°F            | 147°F          | 150°F           |

## *Conclusions*

1. A thermal-ribbon reacts to temperature changes more quickly than a probe inside a brass thermowell. We would expect an even larger improvement in comparison to a stainless steel thermowell.
2. After the system reaches steady state, all three sensors give identical readings. The surface mounted thermal-ribbon is effectively sensing true liquid temperature.

These conclusions have been verified by an independent manufacturer of energy management systems, who conducted a side-by-side comparison in a working installation.

## **Thermal-Ribbon Installation**

When installing a thermal-ribbon, you must ensure that it conforms tightly to the sensed surface and is well insulated from surrounding air. Listed below are instructions for silicone rubber thermal-ribbons. Polyimide thermal-ribbons, typically specified for aerospace use, may have different instructions.

### *Pressure sensitive adhesive (PSA)*

PSA offers easy press-in-place installation, but is restricted to flat surfaces and temperatures below 350°F (177°C). PSA is factory applied and must be specified when ordering a thermal-ribbon. To use PSA:

1. Remove insulation and clean all dirt and oil from the mounting area. Use a wire brush or sandpaper to expose shiny metal.
2. Remove the protective backing paper from the thermal-ribbon and press it in place. Apply pressure to remove voids.
3. Secure leadwires so they do not pull on the thermal-ribbon body.
4. Replace or install insulation.

### *Stretch tape*

Self-adhering silicone rubber tape with two-way stretch is used for quick installation on cylinders. Because there is no adhesive layer between the thermal-ribbon and the pipe, silicone rubber tape provides optimum thermal response. To use tape:

1. Remove insulation and clean all dirt and oil from the mounting area.
2. Position the thermal-ribbon on the pipe, flat side down, and put a bend in the leads for strain relief. Wrap the tape around the thermal-ribbon and pipe a minimum of 1½ turns, maintaining constant tension as you go.
3. Cut the tape and press the end in place. Be sure the tape is clean and the end is firmly adhered.
4. Replace or install insulation.

### *RTV cement*

RTV cement is a room temperature vulcanizing cement suitable for curved surfaces and temperatures to 392°F (200°C). To use cement:

1. Remove insulation and clean all dirt and oil from the mounting area. Use a wire brush or sandpaper to expose shiny metal.
2. Coat the flat mounting surface of the thermal-ribbon with cement. Keep the adhesive layer thin but void-free for best heat transfer.
3. Quickly position the thermal-ribbon on the pipe and apply uniform pressure to remove bubbles.
4. For best results, lightly clamp the thermal-ribbon in place for at least 2 hours. Do not heat the pipe for 24 hours.
5. Secure leadwires so they do not pull on the thermal-ribbon body.
6. Replace or install insulation.

### *Note on leadwires*

Care must be taken to install leadwires so they do not conduct heat away from the thermal-ribbon or pull it loose from the pipe. Some considerations are:

1. Do not allow the leads to hang free where they might be subject to tugs and pulls. When possible, tape them to pipe hangers or mounting brackets.
2. Run the leads along the pipe a few inches before bringing them out through the insulation. This way, the wires will be at the same temperature as the sensor and will not cause conduction errors.

### *Interfacing Thermal-Ribbons to control systems*

When using resistance thermometers, you must be careful to account for leadwire resistance in long signal wire runs. A 3 or 4-wire compensating circuit may be required.

## **Summary**

Thermal-ribbons work well to measure liquid temperature in pipes because they include flexible sensors that conform tightly to the surface. There are no air gaps to block heat transfer, thin electrical insulation reduces thermal gradient between the sensing element and sensed surface, and the element winding senses temperature over a sensed surface area. Rapid thermal response, accuracy and surface-mount simplicity give thermal-ribbons an economic advantage over traditional probe-style sensors and thermowells.



1 Delta Park Blvd, #12 Brampton, ON L6T 5G1  
Tel 905-457-6322 or 1-800-794-5883  
Fax 905-457-4716 or 1-800-830-7122  
[sales@mod-tronic.com](mailto:sales@mod-tronic.com) [www.mod-tronic.com](http://www.mod-tronic.com)